

**INSTRUCTION MANUAL  
FOR**

**HIGH SPEED MOULDING  
MACHINE  
TYPE 170B**

INSTRUCTION BOOK NO : 1405

ATTENTION

THIS MACHINE CAN BE DANGEROUS IF IMPROPERLY USED.

ALWAYS USE GUARDS

KEEP CLEAR UNTIL ROTATION HAS CEASED

ALWAYS OPERATE AS INSTRUCTION AND IN ACCORDANCE WITH GOOD PRACTICE.

READ THE INSTRUCTION MANUAL.

NOTE:

THIS MACHINE, WHEN UNDER WORKING CONDITIONS, MAY PRODUCE A NOISE LEVEL IN EXCESS OF 90 D.B. "MADKIN" PLC., WILL SUPPLY INFORMATION ON ACOUSTICAL ENCLOSURES ON REQUEST, AND WILL REQUIRE A WRITTEN UNDERTAKING THAT THE NECESSARY STEPS WILL BE TAKEN TO ENSURE THAT THE MACHINE IS ONLY USED IN COMPLIANCE WITH THE TERMS OF HEALTH AND SAFETY AT WORK - ACT 1974.

IT IS RECOMMENDED THAT ALL PERSONNEL INVOLVED WITH THE MACHINE ARE ACQUAINTED WITH THE WOODWORKING MACHINES REGULATIONS, 1974, AND ALSO BOOKLET No: 41 - SAFETY IN THE USE OF WOODWORKING MACHINES - THE LATTER IS ISSUED BY THE DEPARTMENT OF EMPLOYMENT AND AVAILABLE FROM HER MAJESTY'S STATIONERY OFFICE.

IMPORTANT

IT IS OUR POLICY AND THAT OF OUR SUPPLIERS TO REVIEW CONSTANTLY THE DESIGN AND CAPACITY OF OUR PRODUCTS. WITH THIS IN MIND WE WOULD REMIND OUR CUSTOMERS THAT WHILST THE DIMENSIONS AND PERFORMANCE DATA CONTAINED HEREIN ARE CURRENT AT THE TIME OF GOING TO PRESS, IT IS POSSIBLE THAT, DUE TO THE INCORPORATION OF LATEST DEVELOPMENTS TO ENHANCE PERFORMANCE, DIMENSIONS AND SUPPLIES MAY VARY FROM THOSE ILLUSTRATED.

## SAFETY RULES

THE SAFE OPERATION OF WOODWORKING MACHINERY REQUIRES CONSTANT ALERTNESS AND CLOSE ATTENTION TO THE WORK IN HAND,

CAREFULLY READ INSTRUCTION MANUAL BEFORE OPERATING MACHINE.

DO NOT OPERATE WITHOUT ALL GUARDS AND COVERS IN POSITION.

BE SURE MACHINE IS ELECTRICALLY EARTHED - GROUNDED.

REMOVE OR FASTEN LOOSE ARTICLES OF CLOTHING - SUCH AS NECK-TIES ETC, CONFINE LONG HAIR.

REMOVE JEWELLERY - SUCH AS FINGER RINGS, WATCHES, BRACELETS ETC.

USE SAFETY FACE SHIELD, GOGGLES, OR GLASSES TO PROTECT EYES AND OTHER PERSONAL SAFETY EQUIPMENT AS REQUIRED.

STOP MACHINE BEFORE MAKING ADJUSTMENTS OR CLEANING CHIPS FROM WORK AREA.

BLUNT CUTTERS OFTEN CONTRIBUTE TO ACCIDENTS. AN EFFICIENT MACHINIST KNOWS WHEN RE-SHARPENING IS NECESSARY, BUT IF THERE IS RELUCTANCE TO SPEND TIME ON GRINDING AND RE-SETTING, THE CUTTERS MAYBE RUN BEYOND THEIR EFFICIENT LIMITS AND INSTEAD OF CUTTING EFFICIENTLY AND SMOOTHLY, THEY TEND TO CHOP AND SNATCH AT THE WOOD. THIS NOT ONLY INCREASES THE RISK OF ACCIDENTS BUT ALSO LOWERS THE QUALITY OF WORK.

CUSTOMERS ARE STRONGLY ADVISED TO USE AT ALL TIMES, HIGH TENSILE STRENGTH CUTTERBLOCK BOLTS WHICH SHOULD BE TENSIONED BY MEANS OF A TORQUE SPANNER.

KEEP THE FLOOR AROUND THE MACHINE CLEAN AND FREE FROM SCRAPS, SAWDUST, OIL OR GREASE TO MINIMISE THE DANGER OF SLIPPING.

IMPORTANT:

FROM TIME TO TIME IT WILL BECOME NECESSARY TO REMOVE THE BUILD UP OF SURPLUS WOOD WASTE (CHIPS) FROM THE INSIDE OF THE FRONT AND REAR LOWER PORTIONS OF THE SOUND ENCLOSURE, TO GAIN ACCESS IT WILL BE NECESSARY TO STOP THE MACHINE, OPEN THE SOUND ENCLOSURE AT THE BOTTOM REAR AND REMOVE THE SURPLUS CHIPS.

OCTOBER, 1982

ALWAYS QUOTE MODEL AND MACHINE NUMBER WHEN ORDERING SPARES

### SPARE PARTS

SHOULD SPARE PARTS BE REQUIRED DUE TO BREAKAGE OR WEAR, FULL PARTICULARS INCLUDING MACHINE AND TEST NUMBER MUST BE GIVEN, THIS INFORMATION IS ON THE NAMEPLATE ATTACHED TO THE FRONT OF THE MACHINE AND SHOULD BE FORWARDED TO THE SERVICE MANAGER.

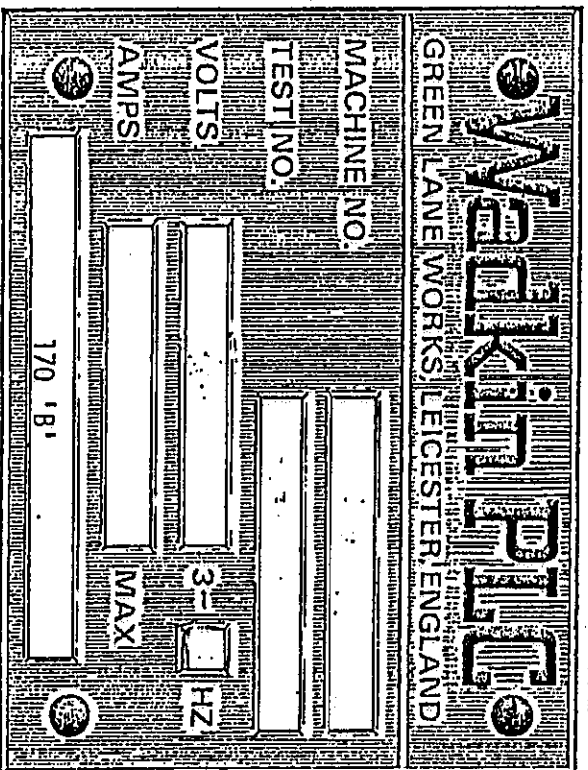

### SAMPLE TYPE ORDER

MACHINE 170 'B'

MACHINE NO:

TEST NO:

PARTS REQUIRED

|   |   |                                     |
|---|---|-------------------------------------|
| 1 | - | M10 x 50mm. long screwed stud       |
| 1 | - | M10 size. bright mild steel washers |
| 1 | - | Raising screw                       |

Madkin PLC., Green Lane Works. Leicester LE5 4PF Telephone: 0533 769111

Cables: Woodworker Leicester

Telex: 34646 (Madkin Leicester)

# ALWAYS QUOTE MODEL AND MACHINE NUMBER WHEN ORDERING SPARES

## INDEX

|  |         |
|--|---------|
| Principal dimensions and capacities  | page 1  |
| Installation   | page 2  |
| Mounting instructions  | page 3  |
| Illustration - Standard machine with outboard bearings   | page 4  |
| NOTE: When setting the digital readouts  | page 5  |
| Bedplates - Control groove in bedplate   | page 6  |
| Joiners - (Where fitted) / Method  | page 7  |
| Adjustments to spindle heads - with outboard bearings (When fitted)  | page 8  |
| Illustration - Close coupled top / bottom heads  | page 9  |
| Illustration - Universal head adjusting mechanism (Where fitted)   | page 10 |
| Universal head in the near side vertical mode  | page 11 |
| The universal head as a top horizontal head  | page 12 |
| Universal head as a near side head   | page 13 |
| The feedworks  | page 14 |
| Lubro-control Unit (15)  | page 15 |
| Oil Lubrication (Bedplate and feedworks)   | page 16 |
| Illustration - Adjustments to bottom feedrolls and infeed fence  | page 17 |
| Illustration - Rise and fall infeed table / bottom feed rolls  | page 18 |
| Infeed table - 2 metres long (Where fitted)  | page 19 |
| Illustration - Feedworks drive   | page 20 |
| Illustration - Feed rolls drive and tension devices  | page 21 |
| Lubrication and maintenance / approved lubricants  | page 22 |
| Maintenance...contd - Feed motor drive   | page 23 |
| Maintenance...contd - Feed motor drive - exploded view   | page 24 |
| "SIMPLABELT" variable speed drive unit - type 11.232.20.20.2   | page 25 |
| Exploded view: "SIMPLABELT" variable speed drive unit  | page 26 |
| General maintenance / Changing the bearings of the cutterblock spindles /<br>Preparation prior to fitting the bearings | page 27 |
| Replacement of parts associated with the motor pulleys   | page 28 |
| Re-fitting the pulleys and taper lock bushes   | page 29 |
| 170B - First bottom horizontal head cutterblock belt driven spindle<br>40mm. dia. (50HZ) drive motor - 6000 RPM.       | page 30 |
| 170B - Fence side vertical head cutterblock belt driven spindle<br>40mm. dia. (50HZ) drive motor - 6000 RPM.           | page 32 |
| 170B - Near side vertical head cutterblock belt driven spindle<br>40mm. dia. (50HZ) drive motor - 6000 RPM.            | page 34 |
| 170B - Top horizontal head cutterblock belt driven spindle<br>40mm. dia. (50HZ) drive motor - 6000 RPM.                | page 36 |
| 170B - Second bottom head cutterblock belt driven spindle<br>40mm. dia. (50HZ) drive motor - 6000 RPM.                 | page 38 |
| 170B - Universal head - adjusting mechanism  | page 40 |
| 170B - Universal head spindle 40mm. dia. square shoulder   | page 42 |

INDEX

Belts and pulleys for machines having an electrical frequency of  
(50) HERTZ / (60) HERTZ

page 44

ILLUSTRATIONS

| FIG NO: | DESCRIPTION  | PAGE NO: |
|---------|--|----------|
| 1       | Mounting instructions  | 3        |
| 2       | Close coupled top / bottom heads   | 9        |
| 3       | Universal head adjusting mechanism (where fitted)                                      | 10       |
| 4       | The universal head as a top horizontal head  | 12       |
| 5       | Lubro-control unit (15)  | 15       |
| 6       | Adjustments to bottom feedrolls and infeed fence (showing a 1 metre long infeed table) | 17       |
| 7       | Rise and fall infeed table / bottom feed rolls   | 18       |
| 8       | Feedworks drive  | 20       |
| 9       | Feed rolls drive and tension devices   | 21       |
| 10      | Feed motor drive   | 23       |
| 11      | Feed motor drive - exploded view   | 24       |
| 12      | Exploded view "SIMPLABELT" variable speed drive unit type 11.232.20.20.2               | 26       |
| 13      | Horizontal cutterblock - belt driven spindle - 40mm. dia.                              | 31       |
| 14      | Vertical cutterblock - belt driven spindle - 40mm. dia.                                | 33       |
| 15      | Vertical cutterblock - belt driven spindle - 40mm. dia.                                | 35       |
| 16      | Horizontal cutterblock - belt driven spindle - 40mm. dia.                              | 37       |
| 17      | Horizontal cutterblock - belt driven spindle - 40mm. dia.                              | 39       |
| 18      | Universal head adjusting mechanism   | 41       |
| 19      | Universal head spindle - square shoulder - 40mm. dia.                                  | 43       |

# 170 B MACHINE

## PRINCIPAL DIMENSIONS AND CAPACITIES

|                                 |                                  |
|---------------------------------|----------------------------------|
| Maximum size of timber admitted | 180mm. x 130mm.                  |
| Maximum size of finished timber | 170mm. x 125mm.                  |
| Feed speed infinitely variable  | 7 - 45metres / minute.           |
| Output of feed motor            | 3.75KW. (5HP)                    |
| Speed of feed motor             | 1430 RPM.                        |
| Feed roll diameter              | 2 x 20mm.wide and .1 x 10mm.wide |
| Feed roll spacers               | 2 x 20mm.wide per station.       |
| Bed height                      | 850mm. (33inches).               |
| Spindle diameters               | 40mm. plain.                     |

## PNEUMATIC LOADING TO FEED ROLLS

All feed rolls adjust in height simultaneously with independent adjustment to rolls after each top horizontal head.

Feedworks 3 rolls at the infeed and two at the top and one at the bottom all driven followed by through feed rolls along the machine and driven cast iron bed roll 172mm. wide after the last bottom head.

Spindle speed of heads 6000 RPM.

Output of head motors (with D.C.Braking)

|                          |                | OPTIONAL        |  |
|--------------------------|----------------|-----------------|--|
| Bottom horizontal        | 5.5KW. (7.5HP) | 7.5KW. (10HP)   |  |
|                          |                | 11.25KW. (15HP) |  |
| Fence side               | 4KW. (5.5HP)   | 5.5KW. (7.5HP)  |  |
|                          |                | 7.5KW. (10HP)   |  |
|                          |                | 11.25KW. (15HP) |  |
| Near side                | 4KW. (5.5HP)   | 5.5KW. (7.5HP)  |  |
|                          |                | 7.5KW. (10HP)   |  |
|                          |                | 11.25KW. (15HP) |  |
| Top horizontal           | 5.5KW. (7.5HP) | 7.5KW. (10HP)   |  |
|                          |                | 11.25KW. (15HP) |  |
|                          |                | 15.0KW. (20HP)  |  |
|                          |                | 18.75KW. (25HP) |  |
| Second bottom horizontal | 5.5KW. (7.5HP) | 7.5KW. (10HP)   |  |
|                          |                | 11.25KW. (15HP) |  |
| Universal head           | 4KW. (5.5HP)   |                 |  |

REFER TO ENCLOSED CHART FOR THE VARIOUS H.P. AND SPINDLE SPEEDS AVAILABLE. (FDR 3087)

## INSTALLATION - 170B

LIFTING FACILITIES. A set of lifting tackle is supplied with each machine. These are supplied on a cash deposit basis, which will be refunded when the tackle is returned to Madkin PLC.

When the machine is sited in its operating position, the lifting tackle must be removed and the roof panels of the sound enclosure replaced.

It is very important to ensure that the lifting slings are suitably arranged to enable the machine to be lifted so that the body is parallel to the floor prior to its siting.

If the floor consists of 150mm. (6in.) solid concrete and it is relatively level then no special foundation is necessary. Since the machine is fitted with anti-vibration supports, holding down bolts should be unnecessary.

### ELECTRICAL DETAILS

THE ELECTRICAL CABLING between all the cutter head motors and the feed roll motor and the attendant control gear have been carried out by Madkin PLC., prior to despatch. It will only be necessary to connect the three-phase power supply to the incoming terminals L1, L2, and L3, at the disconnect switch.

It will also be necessary to bring a single-phase supply to the machine to provide the energy for the three fluorescent light tubes which are embraced within the sound booth.

### ENSURE THAT THE MACHINE IS SOLIDLY CONNECT TO EARTH (GROUND)

- 1) Check that the electrical supply details on the machine nameplate corresponds to the available electrical supply and select the size of the main cable to correspond as near as possible to the current indicated on the machine nameplate.
- 2) Check that the fuses at the electrical supply distribution board are correct.
- 3) Check that all connections are sound.
- 4) If the direction of rotation of the feed rolls is anti-clockwise change over any two connections on the incoming supply.

### PNEUMATICS

The input air pressure should be set at  $5\text{kg/cm}^2$  ( $80\text{lbs/in}^2$ ) gauge.

NOTE: MANUAL D.C. BRAKING IS FITTED TO EACH INDIVIDUAL HEAD.

### SOUND ENCLOSURE

A locking device is provided on the upper front door.

## MOUNTING INSTRUCTIONS

The anti-vibration mountings provides stability in all directions - they are provided with levelling screws for varying and adapting the height of the machine to the floor height. Thus tilting as result of an uneven floor is counteracted.

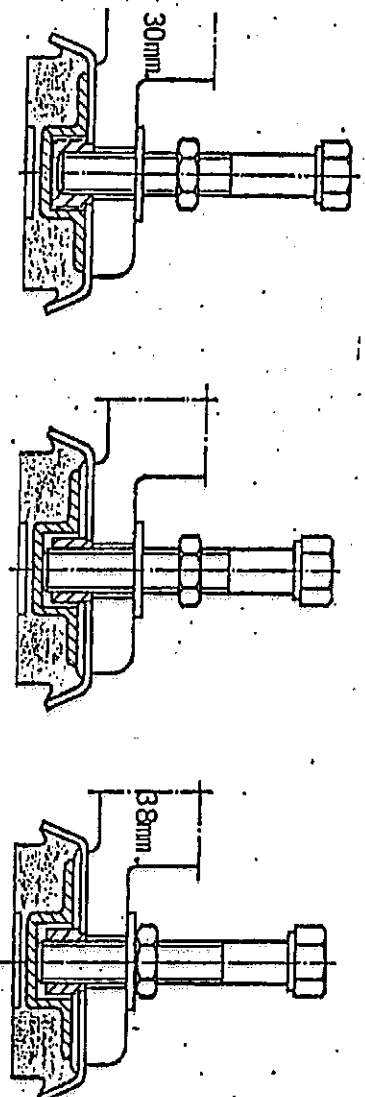
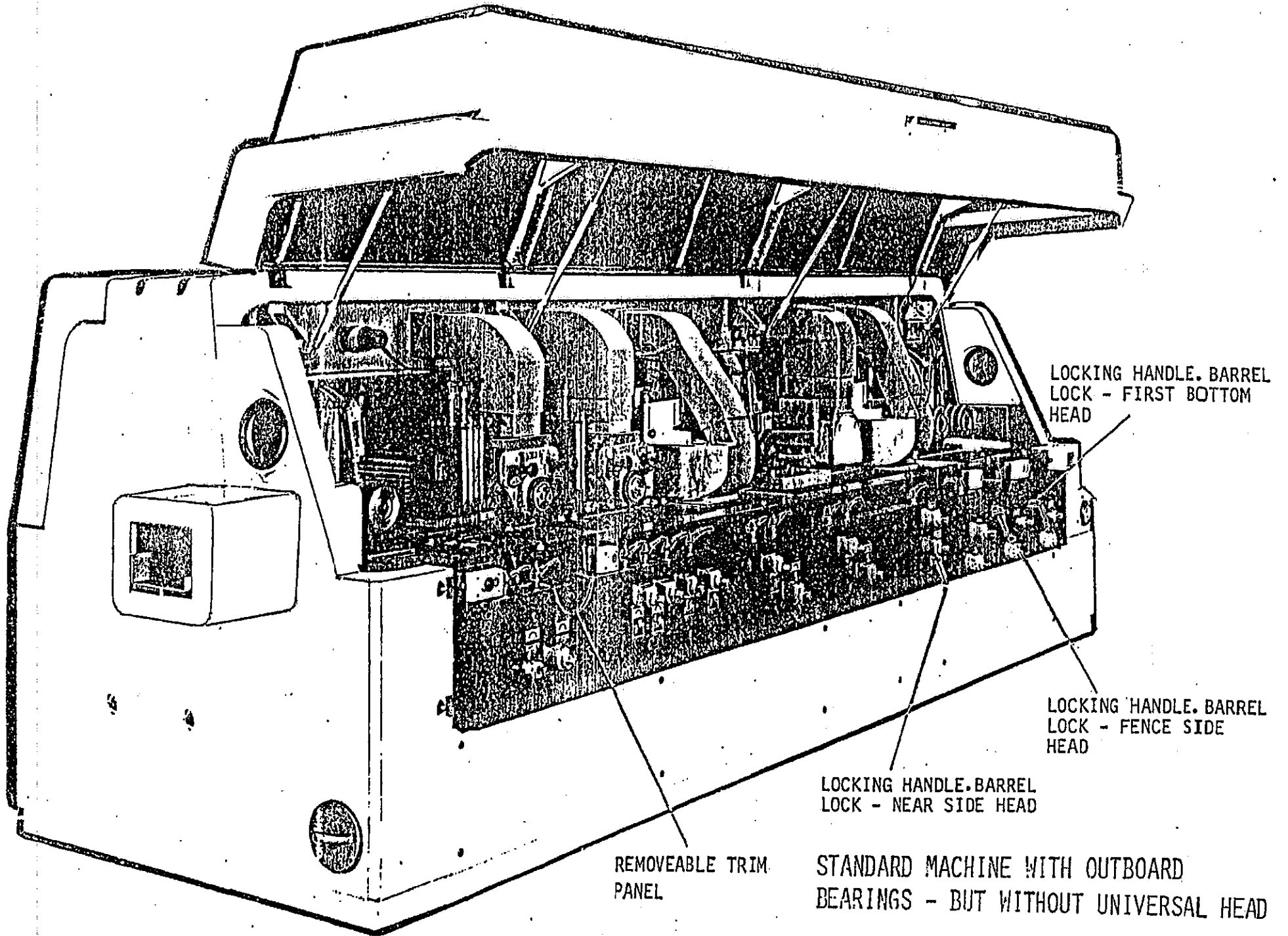

FIG 1

1. The antivibration mounting is fixed to the machine.
2. The machine is balanced horizontally by means of the through levelling screw.
3. The level position is fixed with the locking nut.



**IMPORTANT: WHEN SETTING THE DIGITAL READOUTS**

THE RISE AND FALL TOP HORIZONTAL HEADS DATUM TO BE SET FROM THE CENTRE LINE OF SPINDLE TO THE BEDPLATE.

THE RISE AND FALL TO THE VERTICAL SIDE HEADS DATUM TO BE SET FROM THE SHOULDER OF THE SPINDLE TO THE BEDPLATE.

THE LATERAL MOVEMENT OF THE VERTICAL SIDE HEADS DATUM TO BE SET FROM THE CENTRE LINE OF SPINDLE TO FENCE.

## BEDPLATES

The bedplates between the first bottom head and the second bottom head are grooved to provide a through feed location for the timber.

A tenon is machined on the timber at the first bottom head to locate in the groove, and is removed at the second bottom head.

At the near side head, a secondary sliding bedplate is provided which moves with the head.

An adjustment is provided so that the bedplate plate can be set to a suitable position in relation to the cutterblock.

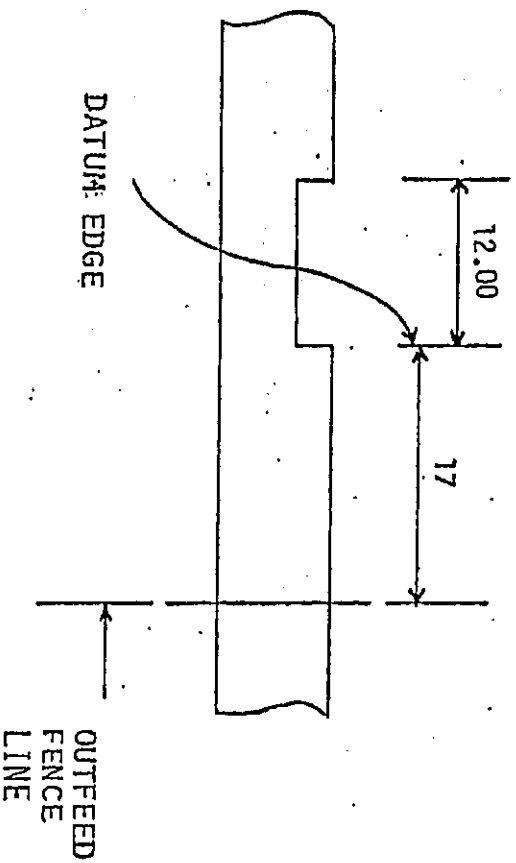

CONTROL GROOVE IN BEDPLATE

## JOINTERS (WHERE FITTED)

Jointing is a means of bringing all the cutters in a multi-knife cutterblock to an absolute common cutting circle.

It is achieved by passing an abrasive stone across the width of the accurately set and balanced block whilst it is rotating at its operating speed.

The jointer remains in a neutral position during the operation of the machine, but for straight jointing is traversed across the cutters by a push-pull handle, hydraulic movement OR a screw.

A fine screw adjustment is provided to feed the jointing stone on to the cutter blades for profile jointing and straight jointing.

### METHOD

Move jointer across the rotating cutterblock and feed the jointing stone gradually onto the blades.

When a spark is generated for straight jointing push-pull the jointer across the blades in an even motion observing the spark.

For profile jointing fine feed the stone into the blades.

It is essential that the jointing stone sparks evenly across the full width of the cutterblock.

When the sparking ceases, the cutter is now jointed, and the jointer may be passed back to its neutral position.

Normally about five jointing operations can be obtained before a maximum heel of 1.1mm (.045in.) is reached and the block is removed for regrinding.

## ADJUSTMENTS TO SPINDLE HEADS - WITH OUTBOARD BEARINGS - WHEN FITTED.

### IMPORTANT NOTE.

All the horizontal spindles are supported by an outboard bearing carried in a bearing housing which is supported by a bearing support bracket....See FIG.2. No attempt must be made to adjust the spindle in any direction without first carrying out the instructions below.

TO MOVE THE SPINDLE IN A VERTICAL DIRECTION, unclamp the bearing support bracket by turning the two clamping handles situated on the front of the trim panel.

When the position of the spindle is set ensure that the bearing support bracket is re-clamped by turning the handles in the direction indicated.

TO MOVE THE SPINDLE AXIALLY the spindle bearing must be released by depressurising the "ETP" bush.

This is accomplished by turning the pressure release screw one quarter of a turn by means of a 3mm. A/F hexagon key (Allen key). When the pressure is released this screw may be retightened.

When the position of the spindle is determined, ensure that the pressure release screw is tightened, apply the grease gun to the grease nipple and pump to a pressure of 450 BAR.

TO CHANGE THE CUTTERBLOCK the bearing housing must be removed. Proceed as follows.

Depressurise the "ETP" bush in the manner described.

Unlock the two hexagon nuts adjacent to the spindle, move the captive 'C' washers to a clear position then withdraw the bearing bracket complete from the spindle.

To replace the bearing bracket proceed in reverse order to the above. Before running the spindle ensure that all nuts are tightened and that the "ETP" bush is correctly pressurised.

### HORIZONTAL SPINDLE ADJUSTMENTS.

The rise and fall movement is effected by a raise and lower screw via. a square ended shaft.

A Locking lever is provided to lock the shaft when the spindle position is set.

The axial movement is effected in a similar manner via. a square ended shaft.

A Locking lever is provided to lock the spindle barrel when the spindle position is set. (This is behind the top pressure at the second bottom head).

### VERTICAL SPINDLE ADJUSTMENT.

The horizontal movement is effected by an adjusting screw via. a square ended shaft.

A Locking lever is provided to lock the shaft when the spindle position is set.

The axial movement is effected in a similar manner via. a square ended shaft.

A Locking lever is provided to lock the spindle barrel when the spindle position is set.

HEXAGON NUTS AND  
CAPTIVE 'C' WASHERS

SPINDLE BARREL LOCK (BEHIND TOP PRESSURE  
SECOND BOTTOM HEAD PAD)

JOINTER  
(WHERE FITTED)

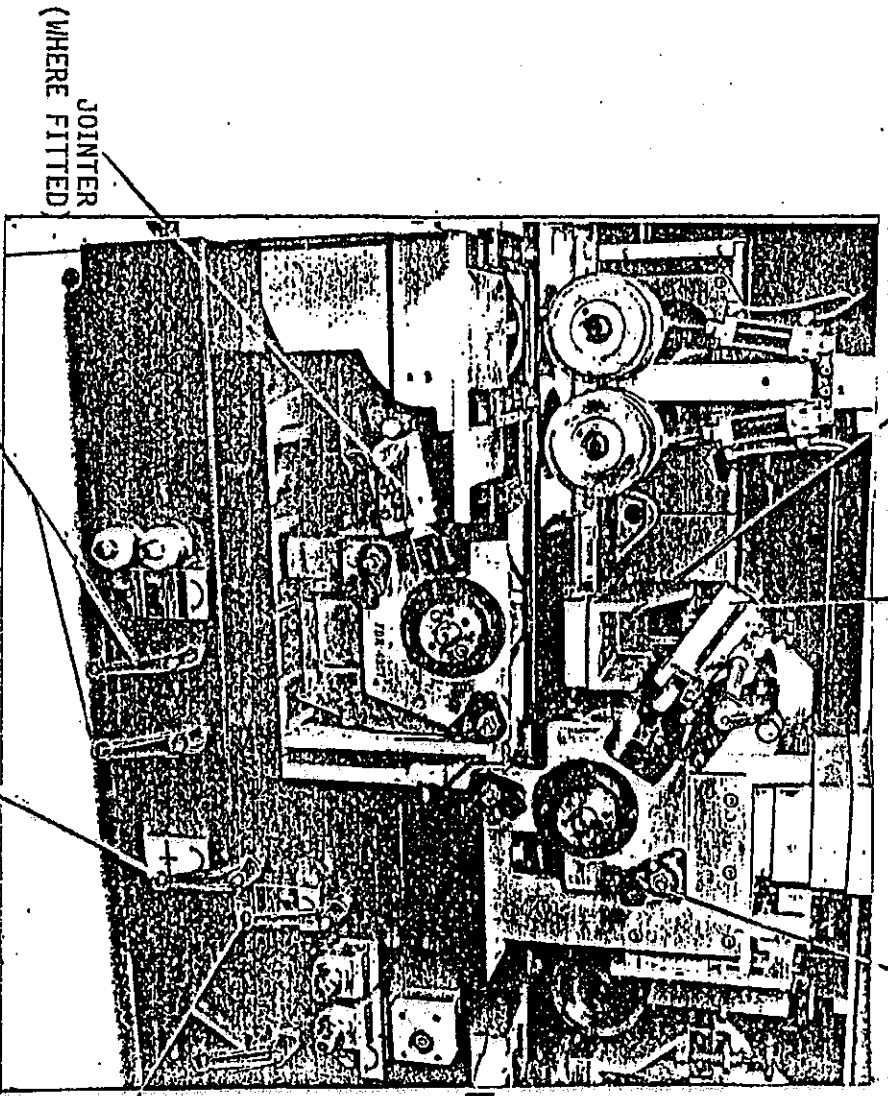

FIG 2

JOINTER  
(WHERE FITTED)

BEARING SUPPORT  
BRACKET CLAMPS

SPINDLE BARREL LOCK  
TOP HEAD

BEARING SUPPORT  
BRACKET CLAMPS  
(NOTE DIRECTION  
OF ROTATION)

CLOSE COUPLED TOP BOTTOM HEADS

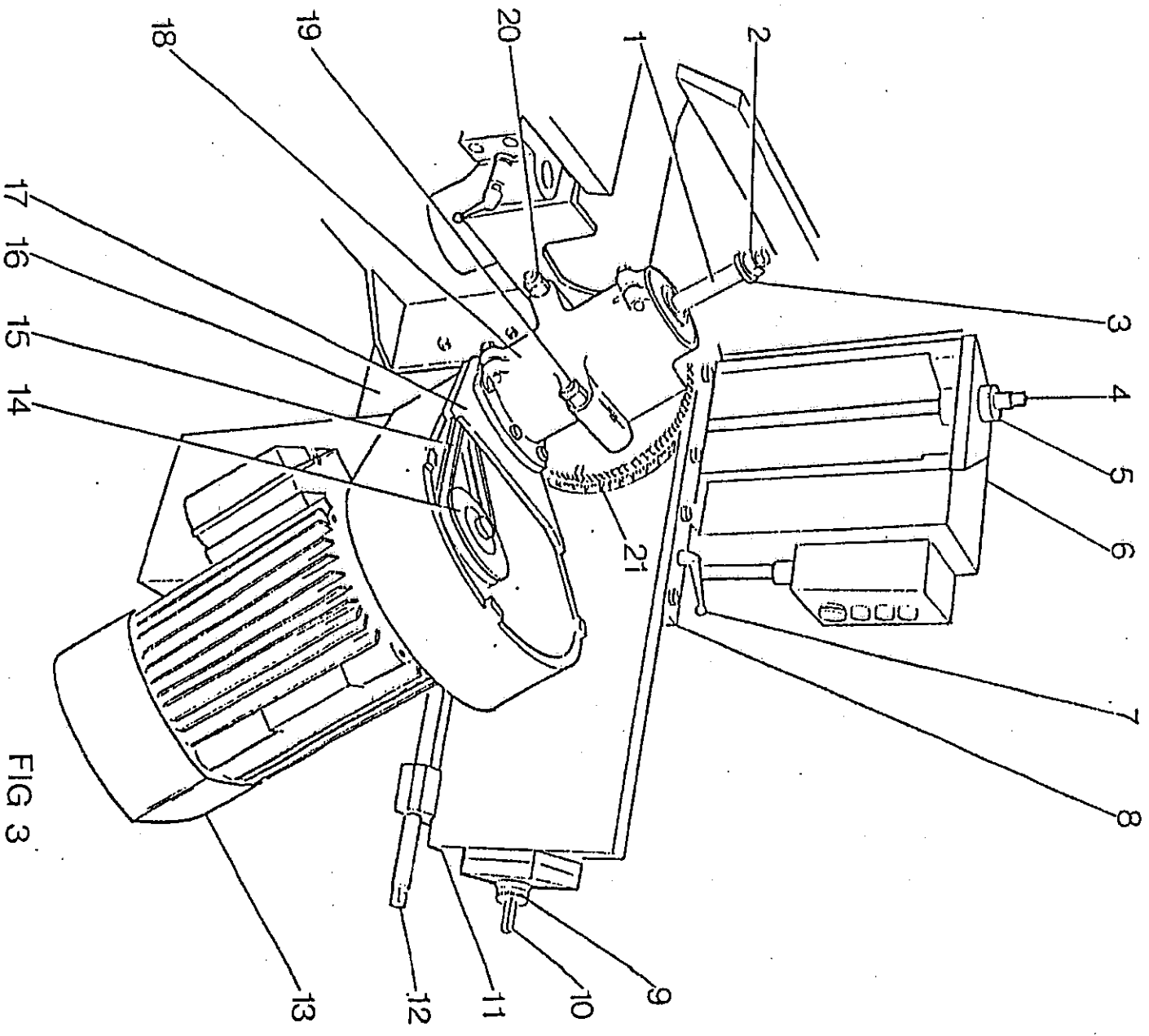

FIG 3

UNIVERSAL HEAD ADJUSTING MECHANISM  
(WHERE FITTED)

## UNIVERSAL HEAD IN THE NEAR SIDE VERTICAL MODE.

The universal head in the near side vertical mode will accommodate a cutter-block having a cutting circle diameter of 100 - 180mm.

The spindle can be canted between the horizontal and vertical modes.

The vertical and lateral movements can be precisely adjusted, from readings on a calibrated dial graduated in increments of 0.1mm.

Before and after the spindle the two adjustable bedplates are arranged to suit the cutting circle of the cutterblock in use when the spindle is in the bottom position

If the spindle is in the canting position OR in the top horizontal position, metal rails are provided as bedplates. The forward rail is fixed by means of two square headed bolts. In this case the outfeed table is adjusted vertically to the same height as the bedplate after the second bottom head. To adjust the spindle vertically - loosen the locking handle. Place crank handle on square and turn clockwise to raise spindle OR anti-clockwise to lower. After adjusting re-tighten the locking handle.

To adjust the spindle laterally - loosen locking handle. Place the crank handle on square (10) and turn clockwise to move forward OR anti-clockwise to move back. After the adjustment re-tighten the locking handle (7).

To cant the universal spindle unscrew the two hexagon nuts (19) and (20) at the spindle carriage and turn the square (12). The angle of cant is measured on graduated scale. Adjust the canting position of the spindle by means of this scale. Re-tighten the two hexagon nuts (19) and (20).

To reverse the direction of rotation of the universal head operate the rotary switch at the electrical control station. The choice of rotation depends upon the position of the spindle. Before commencing to work, momentarily run the spindle to check the direction of rotation.

## UNIVERSAL HEAD AS A BOTTOM HORIZONTAL SPINDLE.

Remove the dust hood which covers the spindle, by unscrewing the fixing screws with the assistance of a 5mm. hexagon key.

Fix the extractor hood on the frame support of the machine by means of two hexagon bolts size M8. x 12mm. Long and connect the extraction pipe. Place the spindle in the required position under the table. In this position always change the cutterblock from the rear of the machine.

The adjustment of the cutterblock in relation to the bedplate is the same method as used for the spindle in a vertical mode.

When working grooved, rabbet OR warped timber the infeed table may not grip the work, in consequence adjust the outfeed table to the same level as the preceding table.

### THE UNIVERSAL HEAD AS A TOP HORIZONTAL HEAD.

Fit the dust hood (57). Remove the pressure rollers and the pressure shoes as well as their clamps and the support bars.

In raising OR canting the spindle take care that it does not come into contact with any part of the machine. Rotate the spindle each time and check the direction of rotation. Replace bedplates with the metal rails. The metal rails are placed side by side and the last one prevents the sideways movement of the others.

The metal's rails ensure the transfer between the infeed and outfeed bedplates and guarantees a continuous feed.

Before feeding the timber make sure that the dust hood is not set too low and that there are no fouling points.

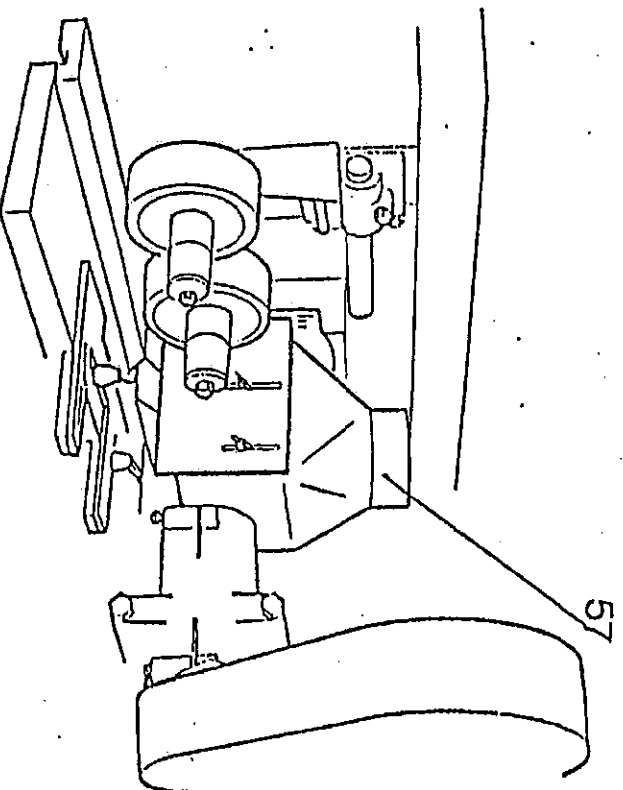

FIG 4

#### UNIVERSAL HEAD AS A NEAR SIDE HEAD.

In the near side vertical position including the canting position when the spindle is raised to the top horizontal position it is only necessary to remove the dust hood. Place the metal rails wide enough to accept the widest piece of timber.

Accurately adjust the roller pressure, the wooden pressure shoes and the side guides on the first piece to ensure a smooth feed. Rotate the spindle in each mode and check the direction of rotation.

#### UNIVERSAL SPINDLE IN THE BOTTOM HORIZONTAL MODE.

Place the spindle in the working position.

Fit the cutterblock. Adjust the bedplates, the outfeed table to suit the spindle. Mount the pressure shoe above the universal cutterhead spindle.

#### UNIVERSAL SPINDLE IN THE TOP HORIZONTAL MODE.

Place the spindle in the working position.

Put the outfeed table at the same height as the infeed bedplate and change the bedplates for the metal rails mount the safety hood.

Fit the cutterblock. Adjust the spindle both laterally and vertically by reading off the calibrated dial. Mount the pressure shoes before and after the cutterblock arbor.

#### UNIVERSAL SPINDLE IN THE NEAR SIDE VERTICAL MODE.

The same adjustments as top horizontal mode. Only put the metal rails to suit the width of the work.

## THE FEEDWORKS

To accomplish "Through Feeding" a series of overhead feed rolls are set at intervals along the length of the machine. There are two top feed rolls and one bottom feed roll at the infeed end of the machine. The swing brackets of the first top feed roll and the bottom feed roll are connected via an air cylinder to give a 'nip-roll' configuration thus ensuring a positive horizontal feed. This cylinder is controlled by its own rotary switch, situated adjacent to the rotary switch which controls the remainder of the top feed rolls, at the right hand end of the enclosure. These are followed by a pair of rolls between the first bottom horizontal head and the fence side vertical head in all there are eight top rolls and two bottom feed rolls on a basic machine, and any additional head is supplemented by an additional roll OR pair of rolls. The rolls are mounted in swings and each one OR pair of rolls are carried from a pivoted bracket and are pneumatically loaded by means of air cylinders. The rolls are flange mounted affording the minimum of projection. The working height of all the top feed rolls can be adjusted simultaneously from a single crank handle at the infeed end of the machine OR those following the top horizontal head(s) can be adjusted independently from a square extension raise and lower screw but before so doing it will be necessary to release lock nut.

The pneumatic cylinders are all controlled simultaneously from a single rotary switch situated at the right hand end of the enclosure. When the switch is in the '0' position the pistons of the cylinders are fully extended 25mm. when the switch is in the '1' position the rolls are fully retracted. The bottom rolls at the infeed end of the machine can be adjusted by handwheel up to maximum 5mm. above the bedplate. The infeed table can be lowered 10mm. maximum by handwheel. All rolls are 140mm. (5.51 inches) diameter. Those up to the first top horizontal head are of steel and have 300 spiral cut teeth. Those rolls following the first top horizontal head are plain and are of polyurethane. All top rolls are interchangeable each feed roll is driven by a shaft through double universal joints and a chain driven sprocket driven from the infeed end of the machine. The chain transmission is driven from an infinitely variable speed gear unit. The chain transmission and variable speed gear unit is driven by a 3.7KW. (5HP) 1500RPM. squirrel cage induction motor. A device is provided to keep the chain correctly tensioned...See illustration FIG.8. The speed range of the feed geared motor unit is 7 to 46 metres/minute (23 to 128 feet/minute). The feed motor can be started, inched (jogged) OR stopped by suitably marked push buttons at the front of the electrical control cubicle. The forward feed inch (jog) push buttons are duplicated at the infeed and outfeed ends of the machine, the buttons in question are paired in such a manner that operation of either set of buttons can only be effected by employing simultaneously both the left and right hands. Adjacent to each pair of feed buttons is a "STOP" button provided with a mushroom head. To operate the button it must be given a sharp tap with the palm of the hand to lock. To release the lock turn the push knob in a clockwise direction. The speed of the feed can be adjusted by a calibrated handwheel located at the front of the machine. **IMPORTANT!...SEE NOTES ON PAGE 20.**

The feed rolls have 25mm. of cylinder movement independent adjustment can be made to the feed rolls after the top horizontal heads. The feed rolls prior to the first top horizontal head are pitched into the fence by an amount of 3mm. in 300mm. The bottom outfeed roll is set by the makers. If necessary this roll can be adjusted to 1mm. maximum above its immediate infeed bedplate. Note! any adjustment made must be compensated for on the outfeed bedplate by shimming.

The infeed fence can be laterally adjusted up to 10mm. the chains of the feed rolls can be tensioned from suitably spaced tensioners and set screws located on the underside of the overhead beam. Should it be necessary to re-tension the main feed drive chain, the chain guard cover must be removed to gain access to the tensioning device adjustment to which is effected by means of the two nuts and the elongated slot.

Lubrication of the chain is via, an oil pump together with an 'ON-OFF' tap for bed lubrication and an 'ON-OFF' tap for chain lubrication situated at the infeed end of the machine. It is recommended that chains should be lubricated once each day. Select correct tap for chain lubrication.

At the initial starting of the feed rolls a fine mist of oil should be added to the air supply by opening the regulator screw on the regulator oiler unit (located at the infeed end of the machine) for a brief period but no longer than five minutes. It will be necessary to repeat this process at intervals of two weeks.

**IMPORTANT:**

IF WORKING CONDITIONS DEMAND INCREASED TRACTION; INCREASE THE AIR PRESSURE AT THE FILTER REGULATOR UNIT LOCATED AT REAR OF THE INFEEED END OF THE MACHINE. UNDER NO CIRCUMSTANCES SHOULD THE TRACTION BE INCREASED BY THE VERTICAL ADJUSTMENT OF THE ROLLS BY THE CRANK HANDLE. FAILURE TO OBSERVE THIS PRECAUTION WILL PRECIPITATE MECHANICAL DAMAGE TO THE FEEDWORKS DRIVE.

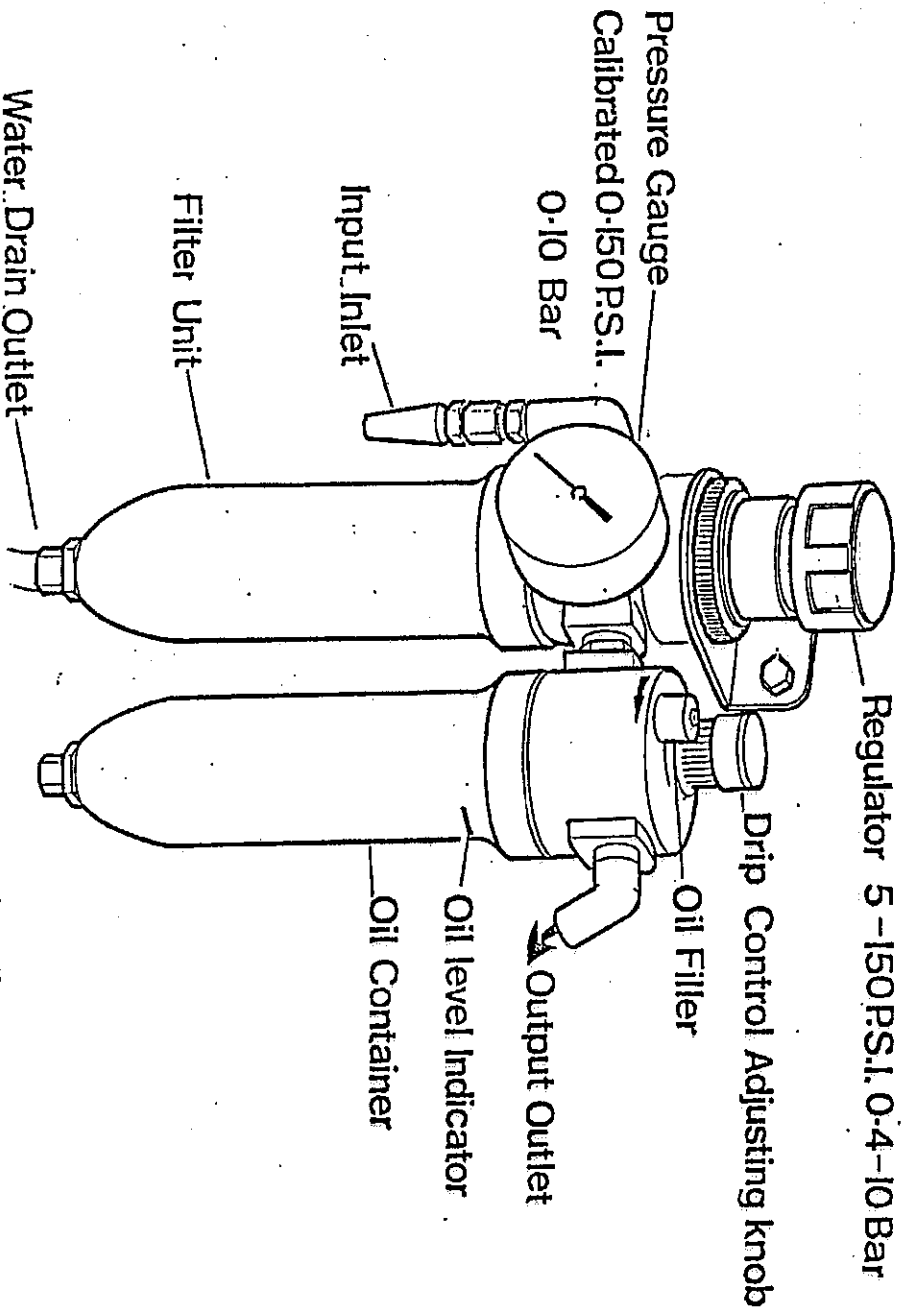

FIG 5

LUBRO - CONTROL UNIT (15)

## OIL LUBRICATION (BEDPLATE AND FEEDWORKS).

Oil lubrication for both the feedworks chains and the grooved bed is from a motor driven pump intergated with a 4.5 litre oil tank - operation of which is carried out by an electrical push button situated in a convenient position for the operator. When re-filling of the oil tank is required this is indicated by a warning light. When lubrication is only required at the grooved bed a tap is provided to isolate the oil feed to the feedworks chains.

The feedworks chains should be lubricated weekly.

The oil feed to the grooved bed should be carried out as required.

Two oiling points are provided on the grooved bed. The first is immediately after the first bottom head, the second immediately before the first top head.

### FEED WHEEL DRIVE SHAFTS.

The 'Universal' joints on the feed wheel drive shafts are provided with grease nipples and should be lubricated weekly.

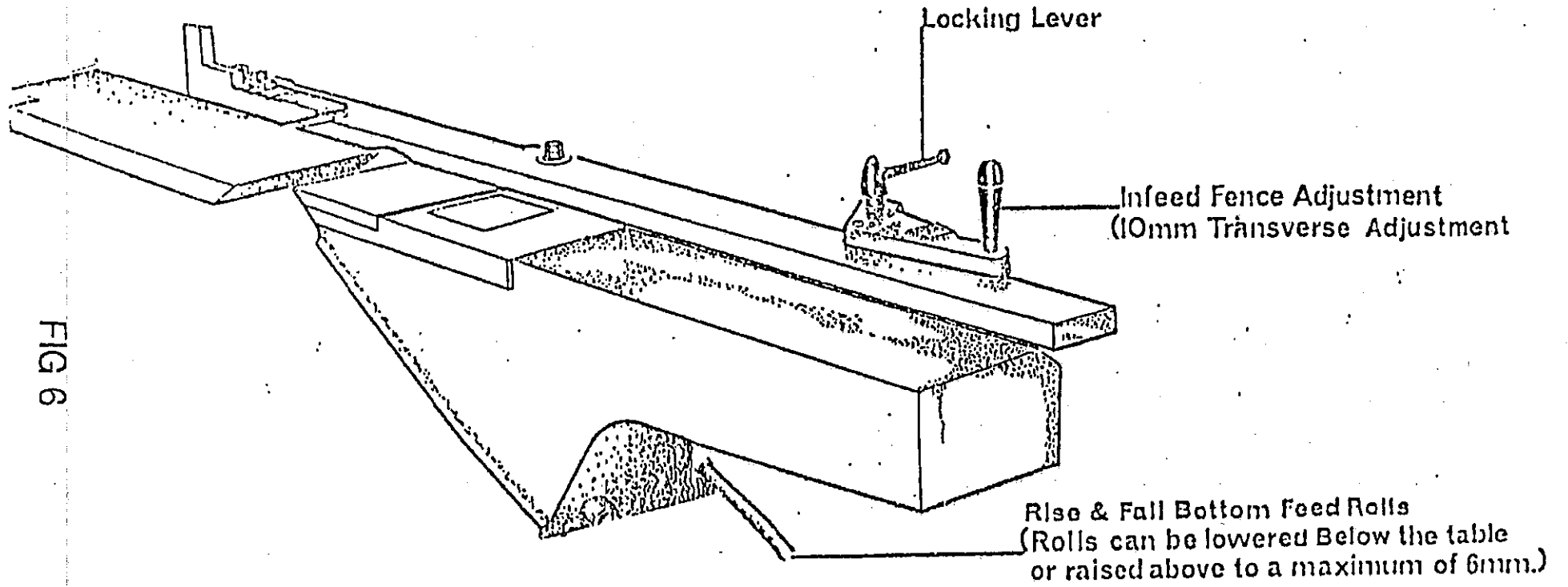
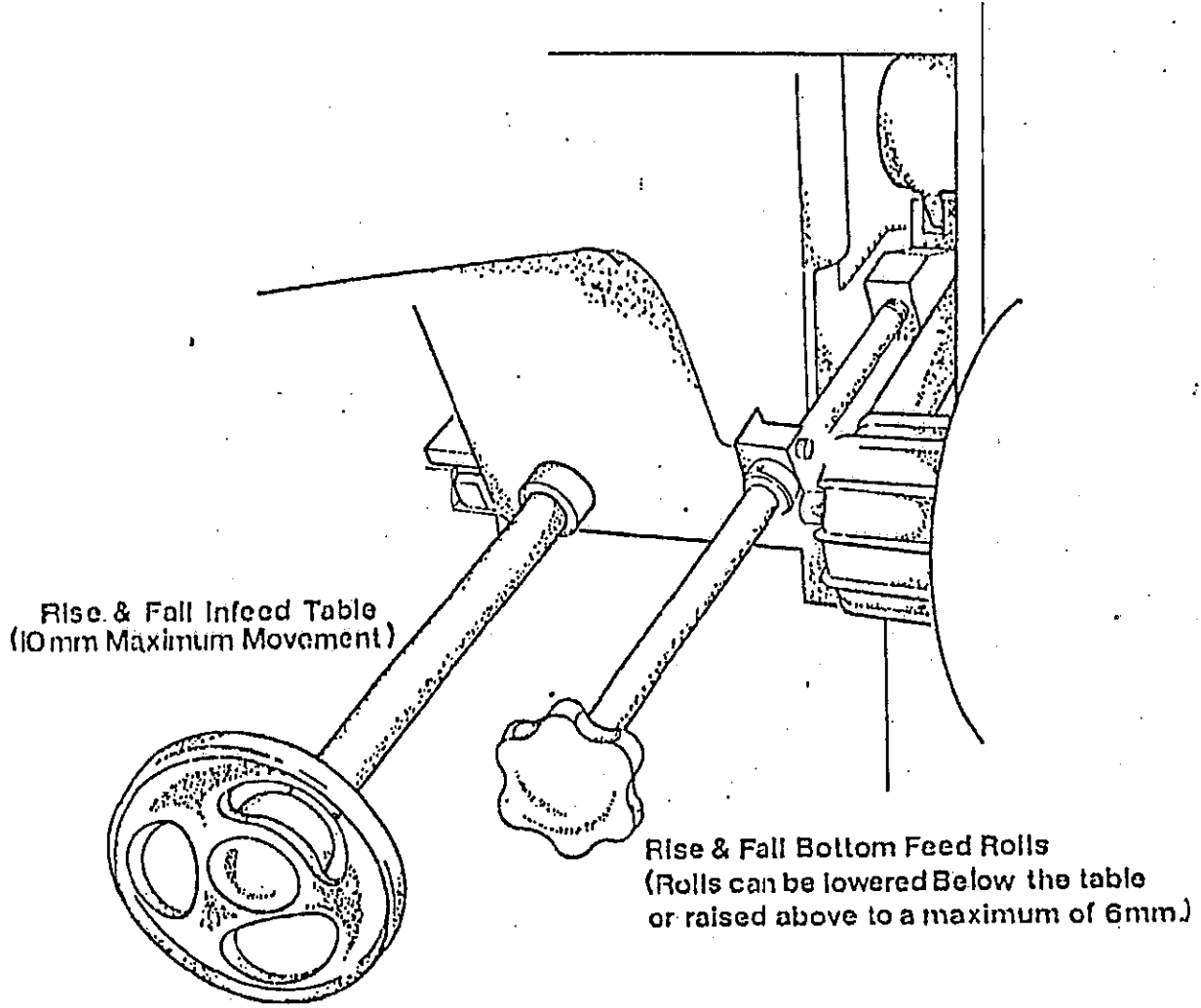

FIG 6

ADJUSTMENTS TO BOTTOM FEEDROLLS AND INFEED FENCE  
(This illustration shows a 1metre long infeed table)

FIG 7



INFEED TABLE - 2 METRES LONG - WHERE FITTED.

To adjust the height of the Infeed table (1) first, unclamp the table by turning handle (2) in an anti-clockwise direction. Set the height required to a direct reading on the graduated scale (3) by moving handle (2) either to the left OR to the right. Re-clamp the table (1) by turning handle (2) in a clockwise direction.

The fence (4) is adjusted with handle (5) reading directly from the graduated scale (6).

NOTE: THIS ILLUSTRATION SHOWS THE INFEED TABLE FITTED WITH "ZIMOMAT" HOPPER FEED UNIT. (ONLY FITTED AS AN OPTIONAL EXTRA).

ADJUSTMENT TO HEIGHT OF TABLE AND OF INFEED FENCE - ARE AS DESCRIBED ABOVE.

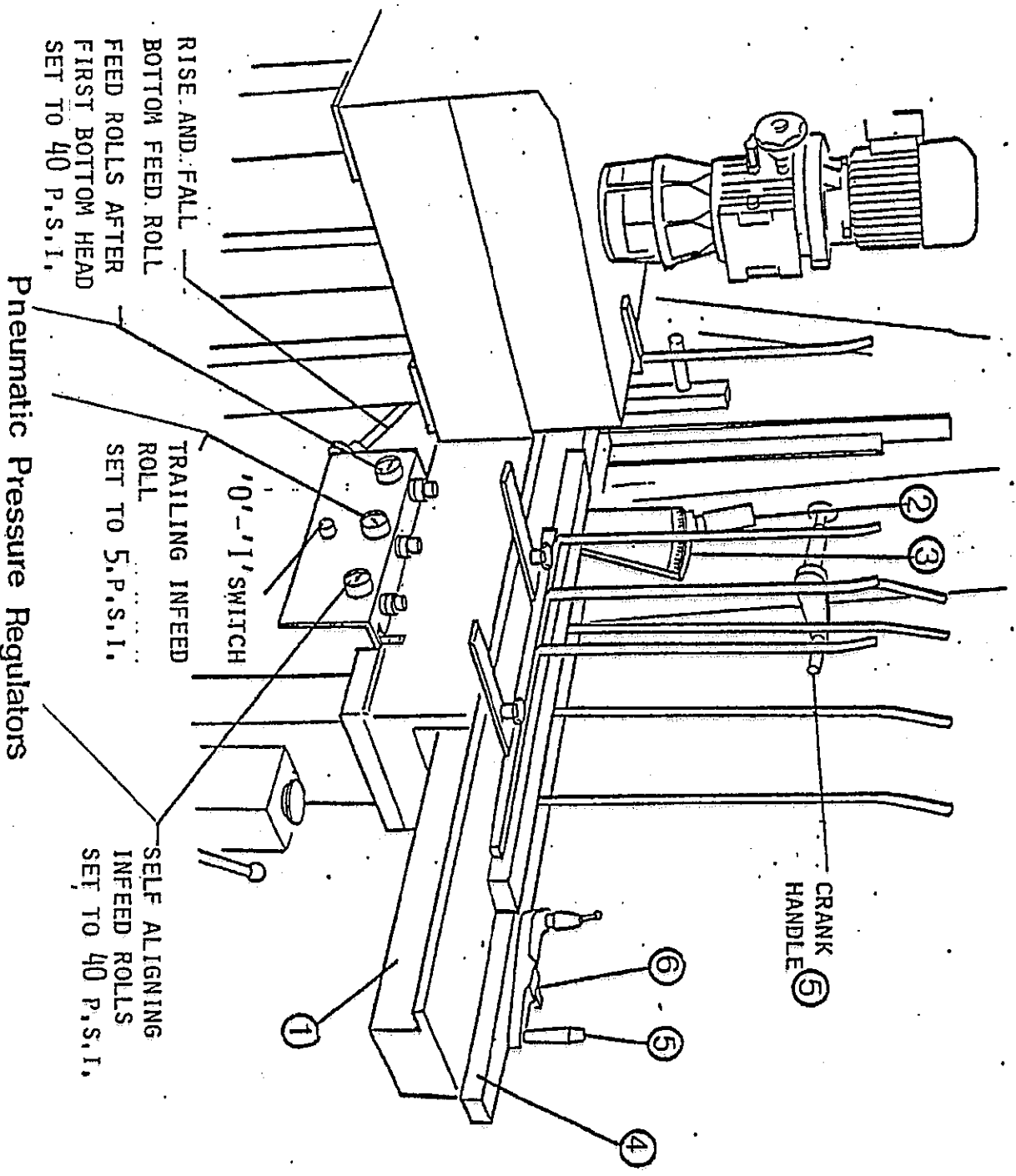

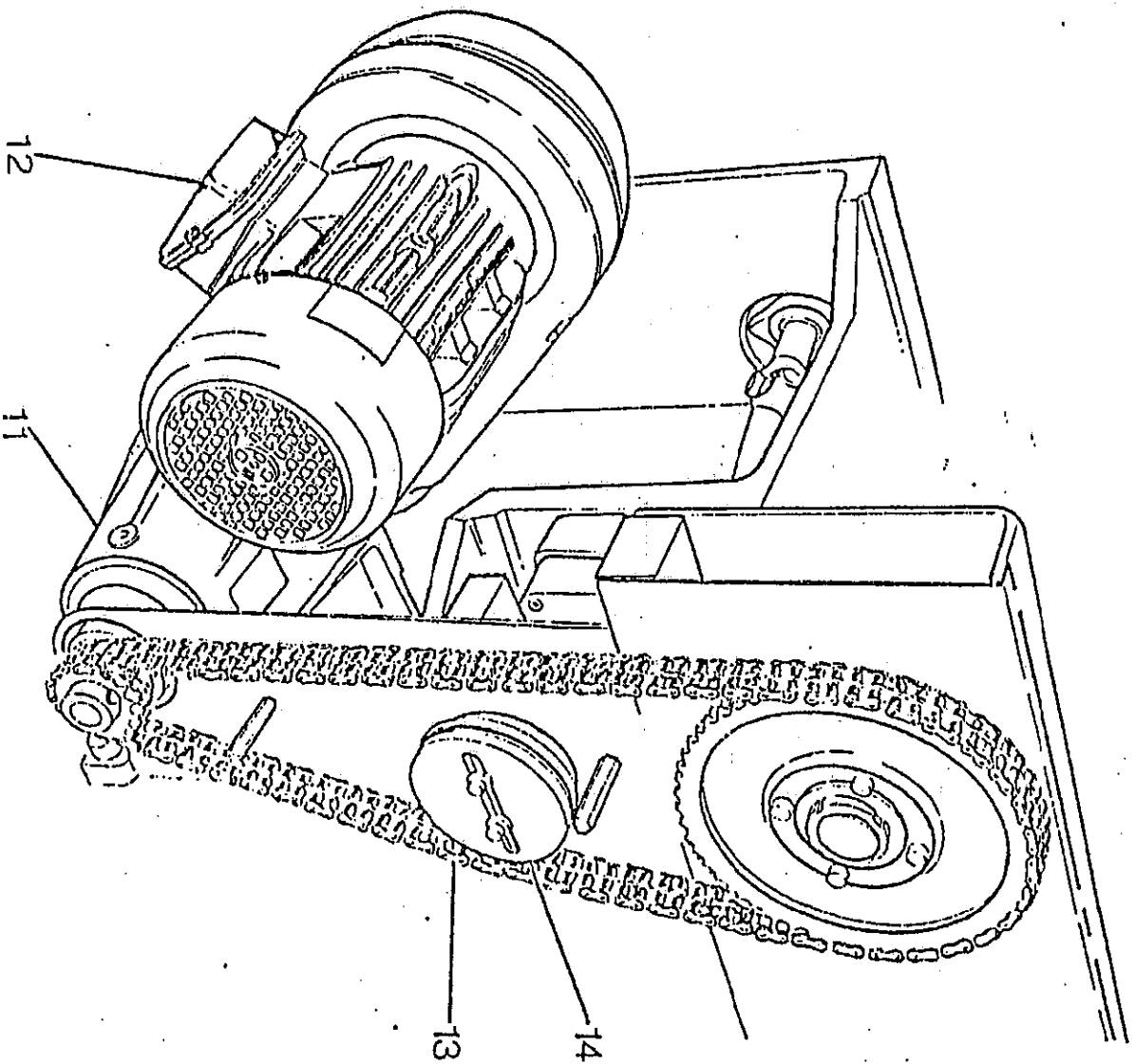

### Feedworks Drive

**IMPORTANT:** Under no circumstances should any attempt be made to adjust the speed of the feed works whilst the unit is stationary.

Adjustment to the feed speed must only be made whilst the feed works are running - otherwise damage to the belt in the variable speed drive unit will occur.

FIG 8

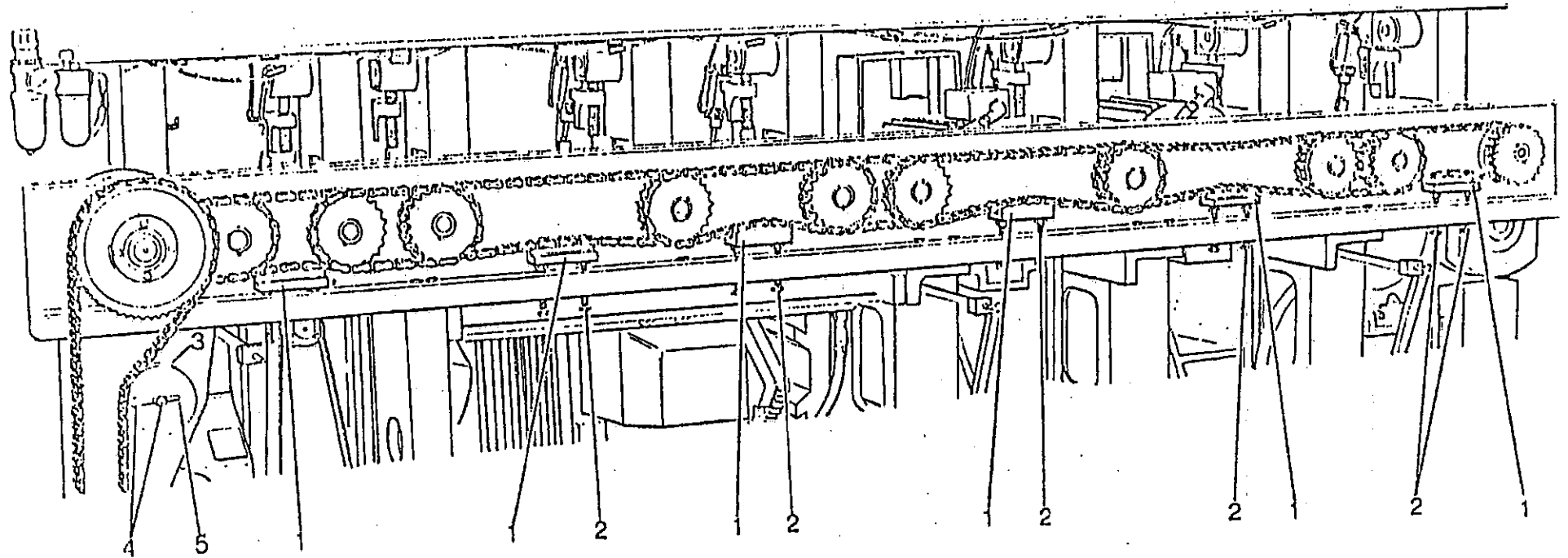

Feed Rolls Drive & Tension Devices

NOTE: LUBRICATION TO THE CHAINS IS NOT ILLUSTRATED

FEED WHEEL DRIVE SHAFTS.

The 'Universal' joints on the feed wheel drive shafts are provided with grease nipples and should be lubricated weekly.

FIG 9

## LUBRICATION AND MAINTENANCE

In designing the "WADKIN" "FDR" Moulder much attention has been given to the question of Maintenance and every endeavour has been made to keep lubrication to a minimum. In consequence of this "sealed for life" bearings and "oilite" bushes have been widely used.

In the places where commercial electric motors have been employed and are not fitted with "sealed for life" bearings then grease nipples are provided.

The cutterblock spindles - have been fitted with permanently lubricated bearings and should give trouble free service.

The pneumatic lubricating unit is conveniently located on the main frame of the machine at the infeed end (rear). It comprises of a filter, regulator, "SOLENOID" and oil dispenser. The latter should be filled with "MOBIL" Almo No.1. Oil. The oil dispenser should be adjusted to give one drip of oil every minute and the air pressure should be regulated to give a pressure of 5.68 kg/cm<sup>2</sup> (80lbs/sq.inch).

### IMPORTANT:

IF WATER CONDENSATION COLLECTS IN THE AIR LINE, IT IS RECOMMENDED THAT AN ELECTRICAL EXTRACTOR AND WATER TRAP COMPLETE WITH "TURN OFF" GAUGE BE INCORPORATED IN THE CIRCUIT IMMEDIATELY BEFORE THE FILTER.

IT IS STRONGLY RECOMMENDED THAT THE VALVE BE OPENED DAILY TO ENSURE THAT WATER DOES NOT ENTER THE AIR LINE.

### EVERY SIX MONTHS

Lubricate all electric motors where lubricators have been provided with "WADKIN" Grade L.6. grease.

The gearbox driving the feedworks does not require periodic lubrication. It is despatched from the works filled with fluid gear grease "SHELL" SIMNIA Grease '0' and should not require any attention for at least 10,000 hours running time. When this time arrives it will be necessary to remove the entire drive from the machine. Replenish the grease via. the combined grease filler/air ventilator with 725 grammes (1.6lbs) grease.

### APPROVED LUBRICANTS

|     | WADKIN | CASTROL      | B.P.             | SHELL               | MOBIL                  | ESSO     | GULF                   | CALTEX                  |
|-----|--------|--------------|------------------|---------------------|------------------------|----------|------------------------|-------------------------|
| L.6 |        | SPHEREOL AP3 | ENERGEGREASE LS3 | ALVANIA GREASE NO.3 | MOBILPLEX GREASE NO.48 | BEACON 3 | GULFCROMIN GREASE No.3 | REGAL STARTAK PREMIUM 3 |

L.6. GREASE MUST NO.3 consistency Lithium bearing grease.

## MAINTENANCE.....CONTD.

The variable speed pulleys incorporated within the feed roll drive are maintenance free.

Should it be necessary to repair the feed drive proceed as follows:-

- 3.1 Dismantle.
- 3.1.1 General dismantling  
Adjust the drive unit to the maximum output speed before dismantling. Switch off drive.
1. Adjustment devices.  
Unscrew socket head capscrews (23) and remove complete adjustment devices (21) (24) (25) OR (26).
2. Speed indicator.  
Unscrew nut (33) and remove housing (32). Loosen nut (30) and unscrew with stud (31).
- 3.1.2 Removing wide section vee belt.  
Unscrew socket head capscrews (20) and whilst supporting the motor (5) separate cover (18) and connecting casting (2) so that the belt (17) can be removed from the variable speed pulley (13). Remove belt (17) from the variable speed pulley (9).
- 3.1.3 Dismantling variable speed pulleys, motor and housing.
  1. Mechanically adjustable variable speed pulley. Unscrew axial tightening screw (16) and remove end cap (14). The Disc.... See Fig.1. is a tooling aid. Assemble the disc behind the circlip of the pulley, and with an extractor remove the pulley (13) from the motor shaft.
  2. Spring loaded variable speed pulley.  
Unscrew axial tightening screw (12) OR screw (27) if with speed indicator, and remove end cap (10). With the aid of an extractor, gripping behind the hub flange of the pulley - remove the pulley (9) from the gearbox shaft, firstly remove the spring and spring retaining cap with a tooling aid.... See Fig.2. Then remove the pulley from the gearbox shaft as indicated in 3.1.3 point 1.
  3. Motor and housing.  
Unscrew hexagon head screw (7) and remove motor. Unscrew hexagon head screw (4) and remove housing.

| Size | a  | b | d     | d <sub>1</sub> | d <sub>2</sub> |
|------|----|---|-------|----------------|----------------|
| 10   | 12 | 3 | 12,11 | 28             | 40             |
| 13   | 12 | 3 | 12,11 | 37             | 50             |
| 16   | 14 | 3 | 14,11 | 42             | 50             |
| 20   | 20 | 4 | 19,11 | 47             | 65             |
| 25   | 25 | 5 | 19,11 | 62             | 80             |
| 31   | 28 | 5 | 19,11 | 72             | 90             |

Fig.1



Fig.2

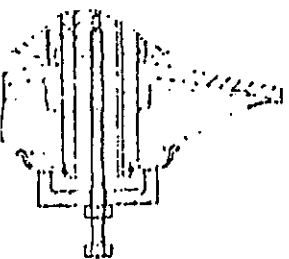

FIG 10

MAINTENANCE CONTD....

3.2 Assembly.

The assembly procedure is in the reverse sequence to the dismantling operation. When refitting the wide section vee belt, it must firstly be placed into the fully opened mechanical variable speed pulley (13), and then over the rim of the spring loaded variable speed pulley (9). Only original "SIMPLABELT" wide section vee belts can be used (part of the guarantee conditions).

4. SPARE PARTS LIST

When ordering spares, all the data shown on the nameplate must be quoted.

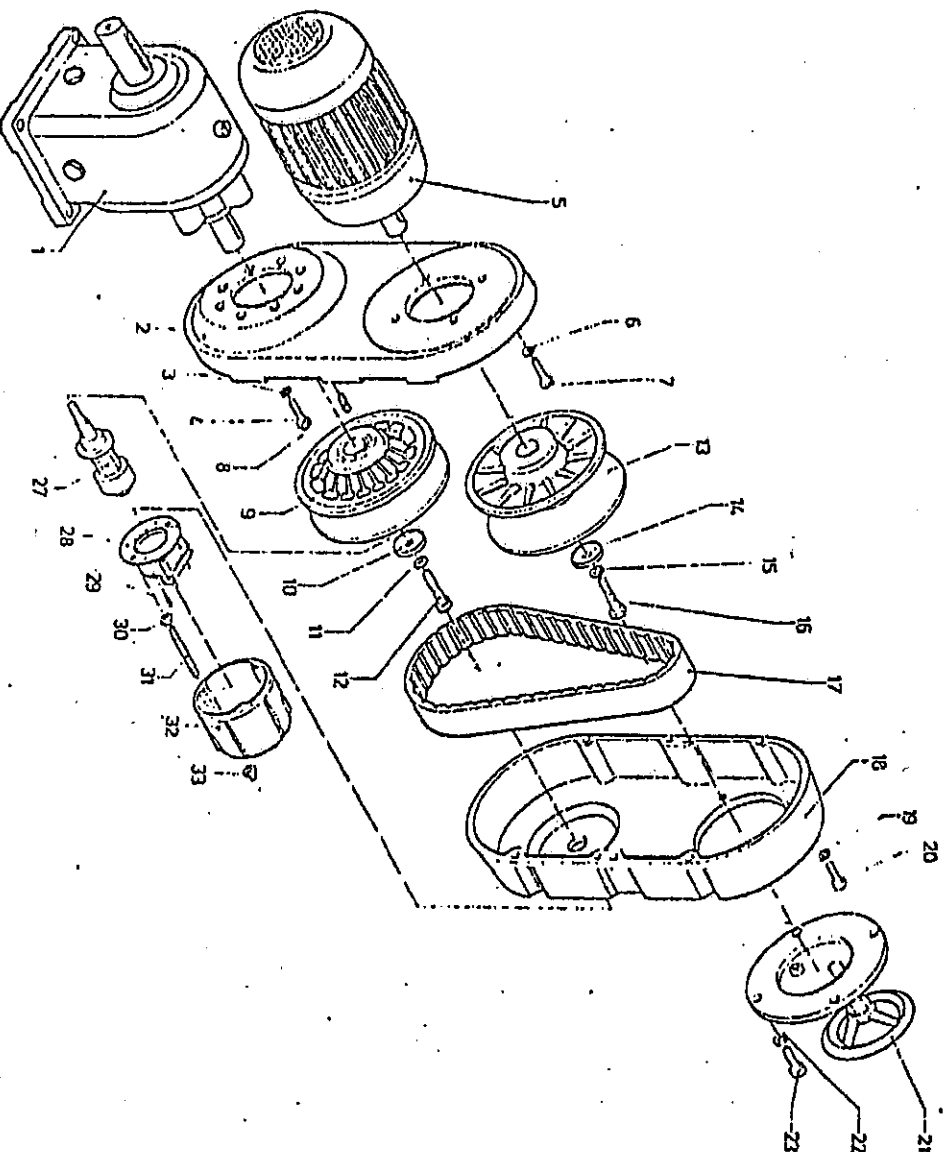

FIG 11



EXPLODED VIEW: "SIMPLABELT" VARIABLE SPEED DRIVE UNIT - TYPE 11.232.20.20.2

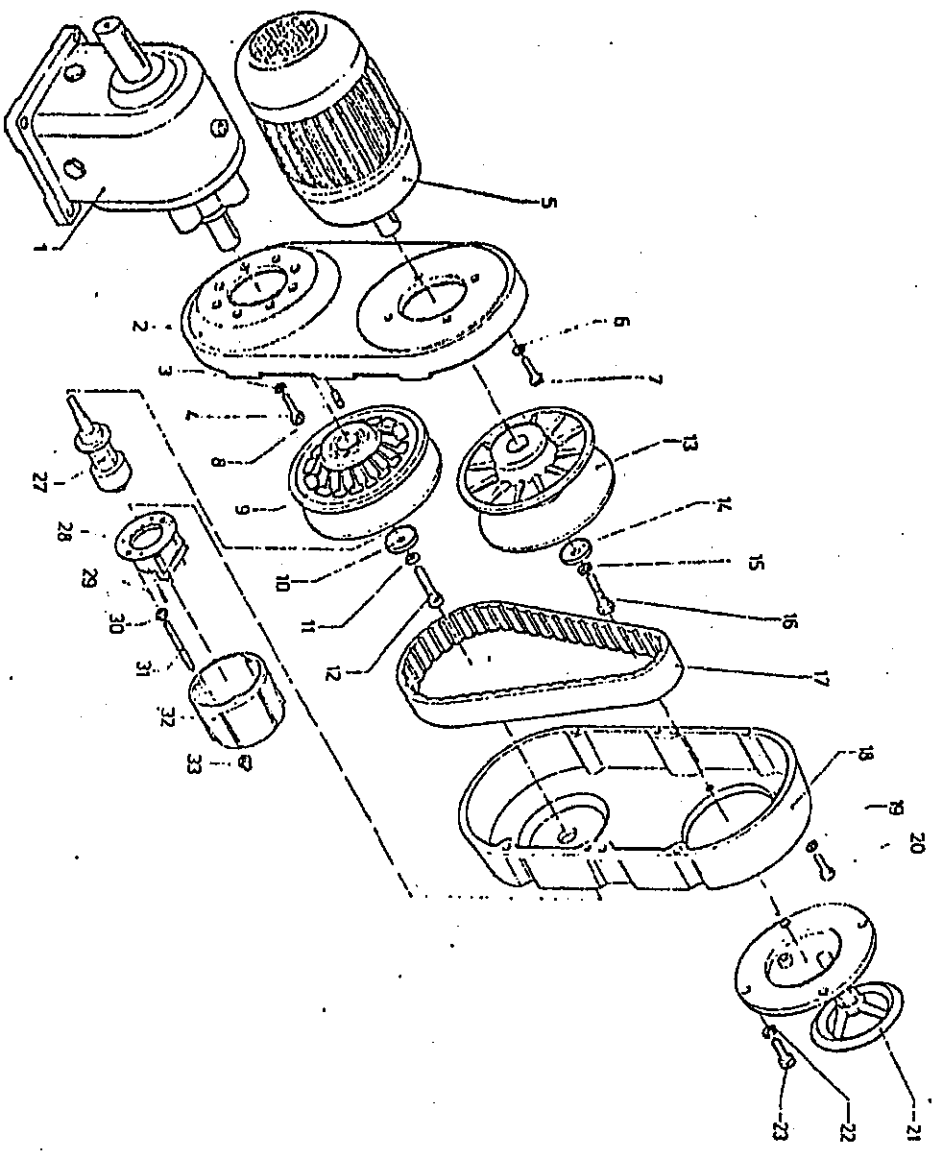
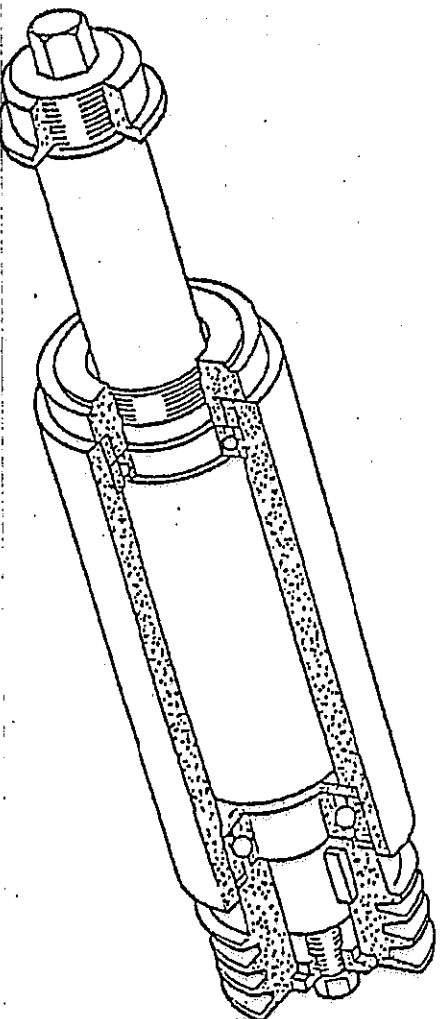

FIG 12

## GENERAL MAINTENANCE

### CHANGING THE BEARINGS OF THE CUTTERBLOCK SPINDLES

The bearings have been fitted to the cutterblock spindle in an orthodox manner.



#### PREPARATION PRIOR TO FITTING THE BEARINGS

Before fitting the new bearing the protective lubricant must be meticulously removed with petroleum spirit trichloroamine OR other volatile solution.

In order to prevent the moving parts from being damaged by over cleansing add a small amount of the new lubricant to the cleansing agent at the second bath. The film of grease which remains after the solvent has evaporated will provide a good protection for the bearing.

At this stage the new bearings should be charged with "KLUBER" lubricant type "ISOFLEX" NBU 15. It is very important that the correct amount of grease be applied to the bearing preferably the amount should be measured by applying the formula  $G = d \times B \times 0.01$  where  $G$  is the weight in grammes, 'd' is the bore of the bearing in mm. and 'B' is the width in mm. OR approximately sufficient to fill one third of the bearing volume.

## REPLACEMENT OF PARTS ASSOCIATED WITH THE MOTOR PULLEYS

- 1) Before access can be made to any belt OR pulley it will be necessary to remove the guard covers.
- 2) Slacken off the tension of motor pulley driving belt. This is effected by loosening the motor fixing bolts on the attendant motor bracket OR the motor tensioner bolts whichever apply. The belts can then be removed.
- 3) The cutterlock spindles are fitted with Vee belt pulleys with keys and the motor shafts are fitted with pulley having taper lock bushes instead of orthodox key.

## TO REMOVE THE TAPER LOCK BUSH FROM THE PULLEYS

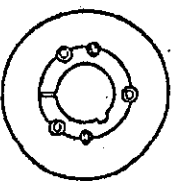
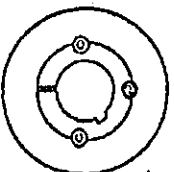
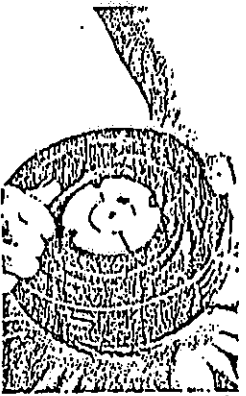

- 1) Slacken all screws by several turns, remove one OR two according to number of jacking off holes shown thus  $\emptyset$  in diagram. Insert screws in jacking off holes after oiling thread and point of grub screws OR thread and under head of cap screws.
- 2) Tighten screws alternately until bush is loosened in hub and assembly is free on shaft.
- 3) Remove assembly from shaft.

## RE-FITTING THE PULLEYS AND TAPER LOCK BUSHES

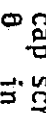
- 1) After ensuring that the mating tapered surfaces are completely clean and free from oil OR dirt, insert bush in hub so that holes line up.
- 2) Oil thread and point of grub screws OR thread under head of cap screws. Place screws loosely in holes threaded in hub, shown thus  in diagram.

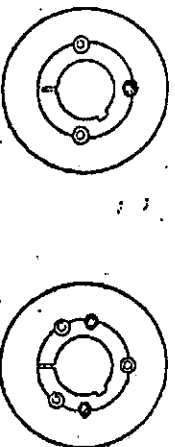

- 3) Clean shaft and fit hub and bush to shaft as one unit and locate in position desired, remembering that bush will nip the shaft first and then hub will be slightly drawn on to the bush.
- 4) Using a hexagon wrench, tighten screws gradually and alternately until all are pulled up very tightly. Use a piece of pipe on wrench to increase leverage.
- 5) After the bush has been tightened on to the shaft fit the parallel key which is side fitting with top clearance.
- 6) After drive has been running under load for a short time, stop and check tightness of screws.
- 7) Fill empty holes with grease to exclude dirt.

### IMPORTANT :-

CHECK THE CONDITION AND TENSION OF THE CUTTER SPINDLE  
DRIVE BELTS AT REGULAR INTERVALS.

ALWAYS QUOTE MODEL AND MACHINE NUMBER WHEN ORDERING SPARES

170B - FIRST BOTTOM HORIZONTAL HEAD CUTTERBLOCK BELT DRIVEN SPINDLE 40mm DIA.  
(50HZ) DRIVE MOTOR - 6000 RPM.

SECTIONS C37 C52  
C41 C44

| REF.NO: | DESCRIPTION                           | NO:OFF |
|---------|---------------------------------------|--------|
| 1       | Spindle barrel                        | 1      |
| 2       | Washer                                | 1      |
| 3       | Spacer for pulley seal                | 1      |
| 4       | Spindle pulley                        | 1      |
| 5       | Bearing locknut and grease retainer   | 1      |
| 6       | Motor pulley                          | 1      |
| 7       | Key 12mm. x 8mm. x 5mm.               | 1      |
| 8       | Hexagon head screw M12. x 35mm.       | 1      |
| ∅ 9     | 7209 TAU EP7 RHP bearing              | 1      |
| ∅ 10    | 7011 TAU EP7 RHP bearing              | 1      |
| 11      | Disc spring for bearing 6209          | 4      |
| 12      | 170mm. x 85mm. x 10mm. Labyrinth seal | 1      |
| 13      | Spindle locking nut M35.              | 2      |
| 14      | 40mm. dia. bottom head spindle        | 1      |
| 15      | Bearing locknut - left hand           | 1      |
| 16      | 35mm. dia. washer                     | 1      |
| 17      | Wedge belts "FENNER" SPZ 1400         | 4      |

∅ "KLUBER" grease packed

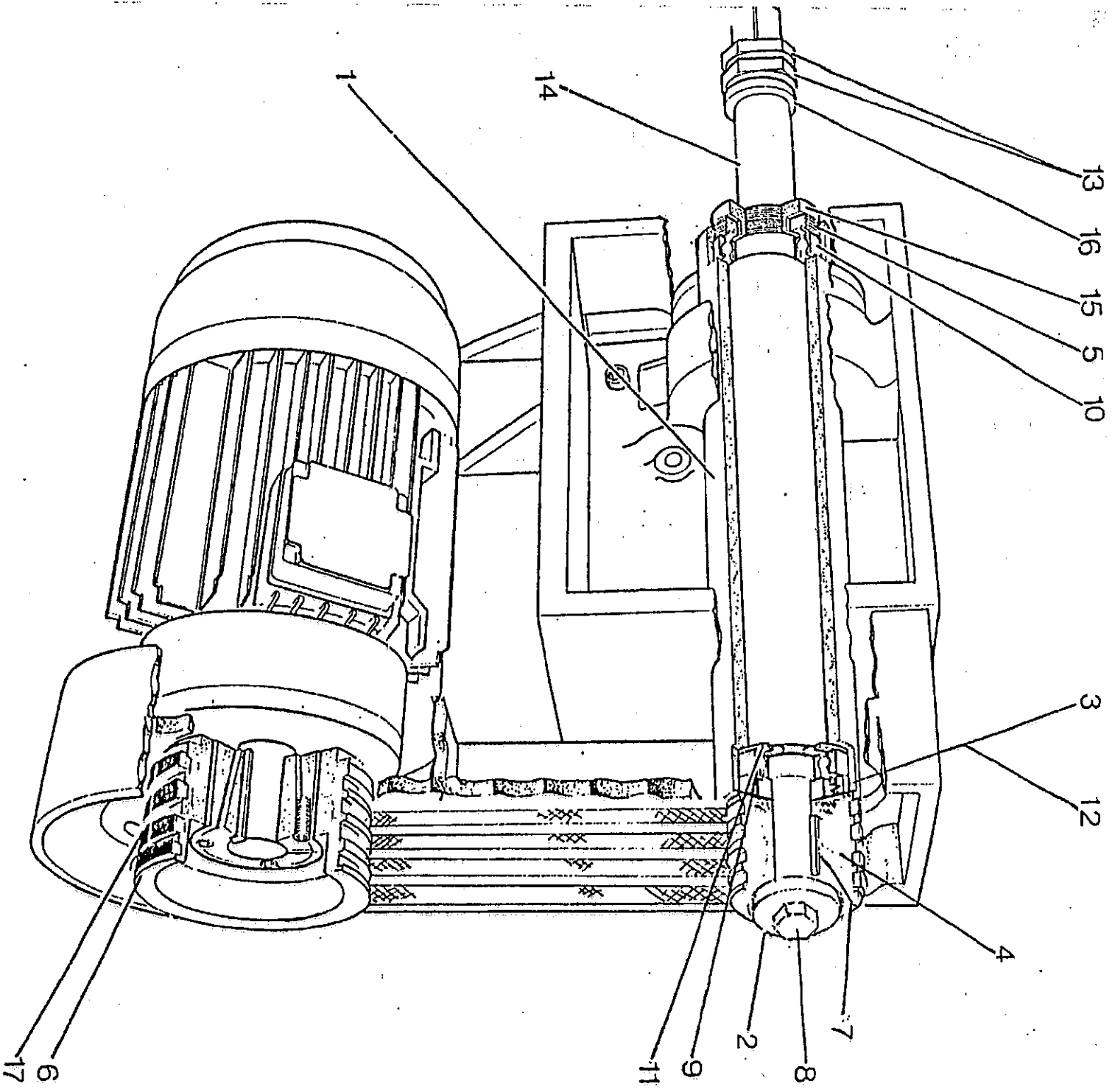

HORIZONTAL CUTTERBLOCK BELT DRIVEN SPINDLE 40mmDia. 6000rpm

FIG 13

ALWAYS QUOTE MODEL AND MACHINE NUMBER WHEN ORDERING SPARES

170B - FENCE SIDE VERTICAL HEAD CUTTERBLOCK BELT DRIVEN SPINDLE - 40mm. DIA.  
(50HZ) DRIVE MOTOR - 6000 RPM.

SECTIONS C37 C52  
C38 C44

| REF. NO: | DESCRIPTION                           | NO: OFF |
|----------|---------------------------------------|---------|
| 1        | Spindle barrel                        | 1       |
| 2        | Washer                                | 1       |
| 3        | Spacer for pulley seal                | 1       |
| 4        | Spindle pulley                        | 1       |
| 5        | Bearing locknut and grease retainer   | 1       |
| 6        | Motor pulley                          | 1       |
| 7        | Key 12mm. x 8mm. x 50mm.              | 1       |
| 8        | Hexagon head screw M12 x 35mm.        | 1       |
| ∅ 9      | 7209 TAU EP7 RHP bearing              | 1       |
| ∅ 10     | 7011 TAU EP7 RHP bearing              | 1       |
| 11       | Disc spring for bearing 6209          | 4       |
| 12       | 170mm. x 85mm. x 10mm. labyrinth seal | 1       |
| 13       | Spindle locking nut M35.              | 2       |
| 41       | 40mm. dia. fence side head spindle    | 1       |
| 15       | Ball bearing locknut - right hand     | 1       |
| 16       | 35mm. dia. washer                     | 1       |
| 17       | Wedge belts "FENNER" SPZ 1470         | 4       |

∅ "KLUBER" grease packed

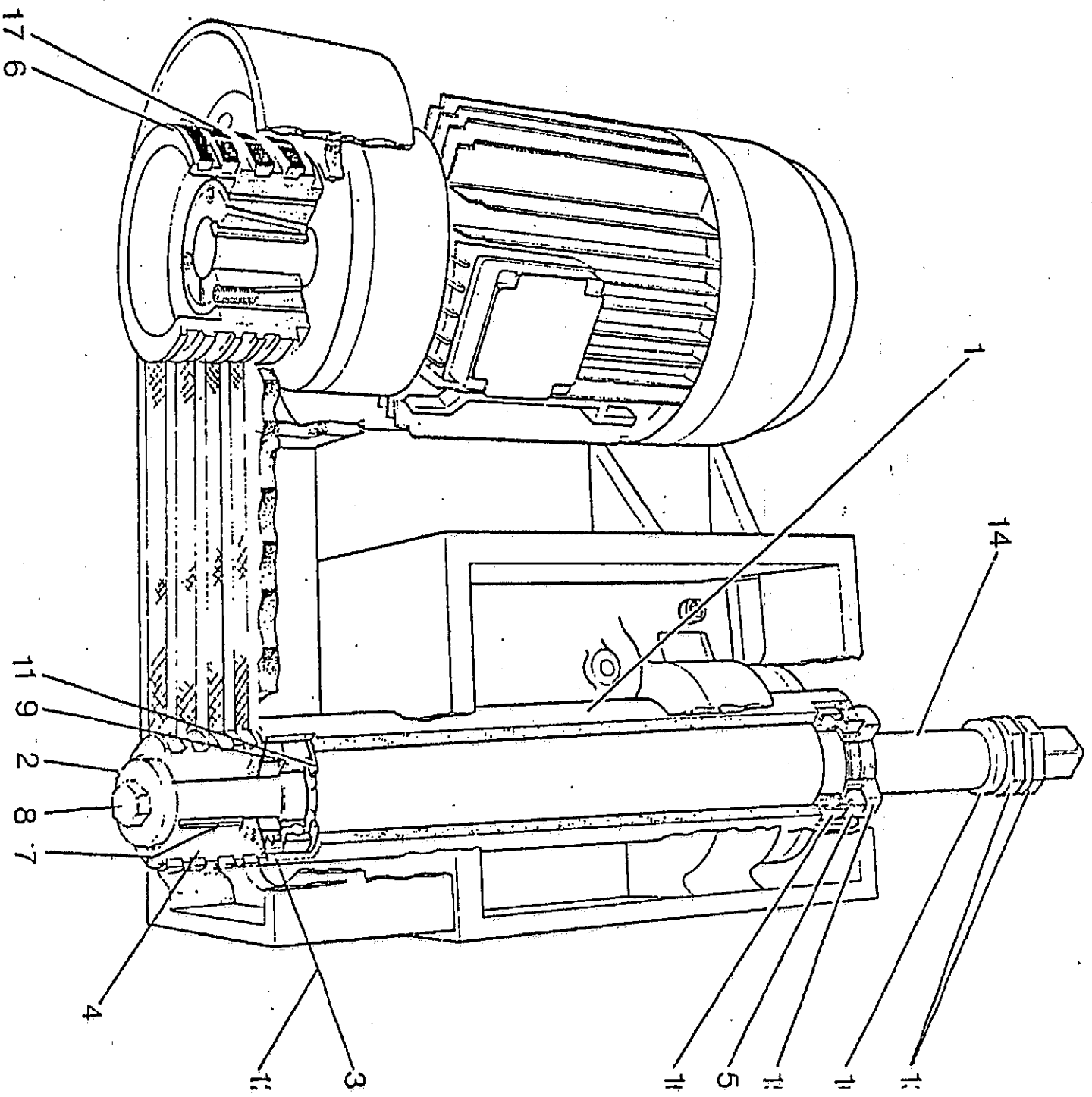

VERTICAL CUTTERBLOCK BELT DRIVEN SPINDLE 40mm Dia. 6000rpm

FIG 14

ALWAYS QUOTE MODEL AND MACHINE NUMBER WHEN ORDERING SPARES

170B - NEAR SIDE VERTICAL HEAD CUTTERBLOCK BELT DRIVEN SPINDLE - 40mm.DIA.  
(50HZ) DRIVE MOTOR - 6000 RPM.

SECTIONS C37 C44  
C39 C54

| REF.NO: | DESCRIPTION                           | NO:OFF |
|---------|---------------------------------------|--------|
| 1       | Spindle barrel                        | 1      |
| 2       | Washer                                | 1      |
| 3       | Spacer for pulley seal                | 1      |
| 4       | Spindle pulley                        | 1      |
| 5       | Bearing locknut and grease retainer   | 1      |
| 6       | Motor pulley                          | 1      |
| 7       | Key 12mm. x 8mm. x 50mm.              | 1      |
| 8       | Hexagon head screw M12. x 35mm.       | 1      |
| Ø 9     | 7209 TAU EP7 RHP bearing              | 1      |
| Ø 10    | 7011 TAU EP7 RHP bearing              | 1      |
| 11      | Disc spring for bearing 6209          | 4      |
| 12      | 170mm. x 85mm. x 10mm. labyrinth seal | 1      |
| 13      | Spindle locking nut M35.              | 2      |
| 14      | 40mm. dia. near side head spindle     | 1      |
| 15      | Bearing locknut - left hand           | 1      |
| 16      | 35mm. dia. washer                     | 1      |
| 17      | Wedge belts "FENNER" SPZ 1700         | 4      |

Ø "KLUBER" grease packed

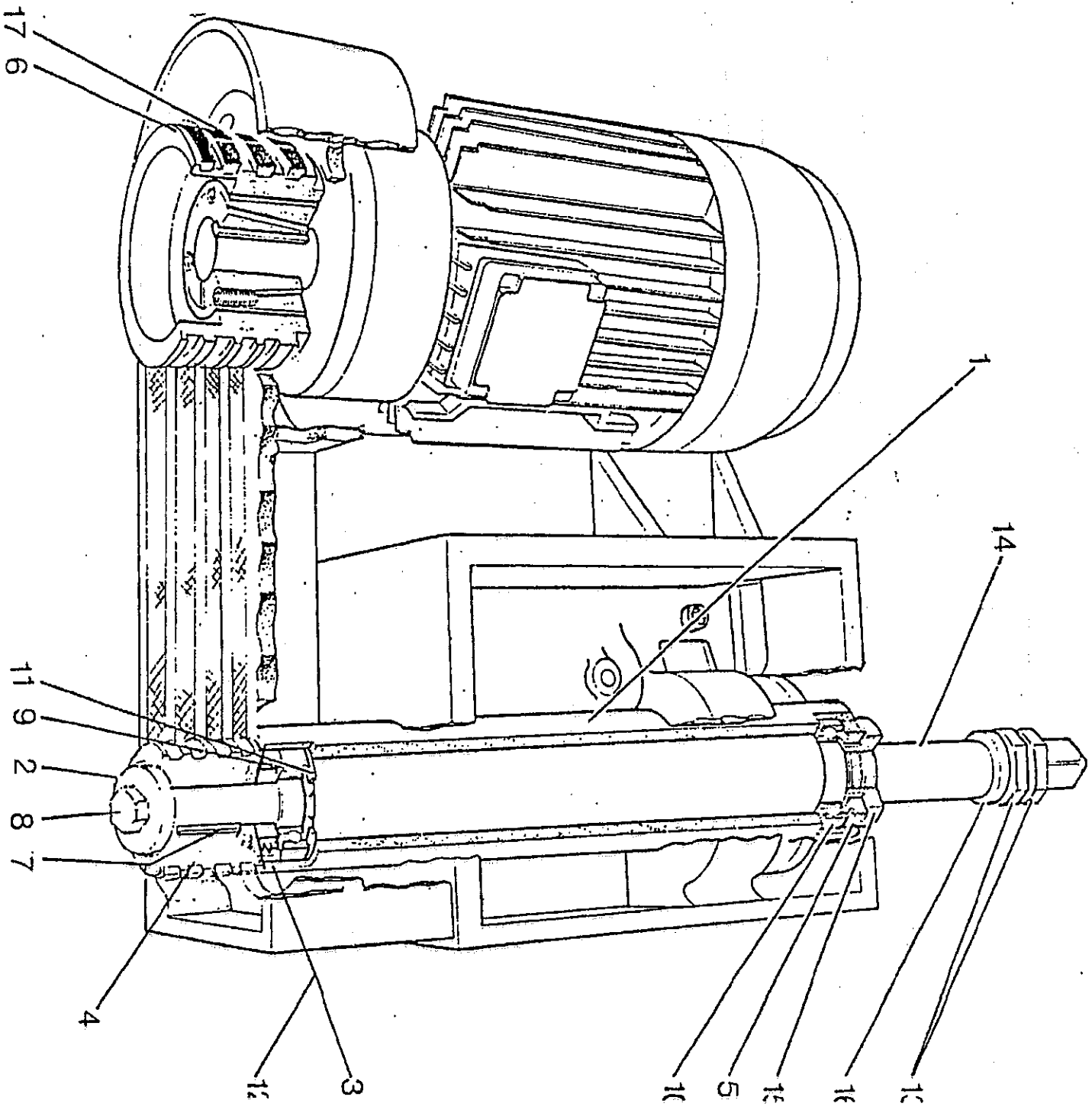

VERTICAL CUTTERBLOCK BELT DRIVEN SPINDLE 40mm Dia.6000rpm

FIG 15

ALWAYS QUOTE MODEL AND MACHINE NUMBER WHEN ORDERING SPARES

1708 - TOP HORIZONTAL HEAD CUTTERBLOCK BELT DRIVER SPINDLE - 40mm.DIA.  
 (50HZ) DRIVE MOTOR - 6000 RPM.

SECTIONS C37 C44  
 C40 C61

| REF.NO: | DESCRIPTION                           | NO:OFF |
|---------|---------------------------------------|--------|
| 1       | Spindle barrel                        | 1      |
| 2       | Washer                                | 1      |
| 3       | Spacer for pulley seal                | 1      |
| 4       | Spindle pulley                        | 1      |
| 5       | Bearing locknut and grease retainer   | 1      |
| 6       | Motor pulley                          | 1      |
| 7       | Key 12mm. x 8mm. x 50mm.              | 1      |
| 8       | Hexagon head screw M12. x 35mm.       | 1      |
| Ø 9     | 7209 TAU EP7 RHP bearing              | 1      |
| Ø 10    | 7011 TAU EP7 RHP bearing              | 1      |
| 11      | Disc spring for bearing 6209          | 4      |
| 12      | 170mm. x 85mm. x 10mm. labyrinth seal | 1      |
| 13      | Spindle locking nut M35.              | 2      |
| 14      | 40mm. dia. top head spindle           | 1      |
| 15      | Ball bearing locknut - right hand     | 1      |
| 16      | 35mm. dia. washer                     | 1      |
| 17      | Wedge belts "FENNER" SPZ 2000         | 4      |

Ø "KLUBER" grease packed

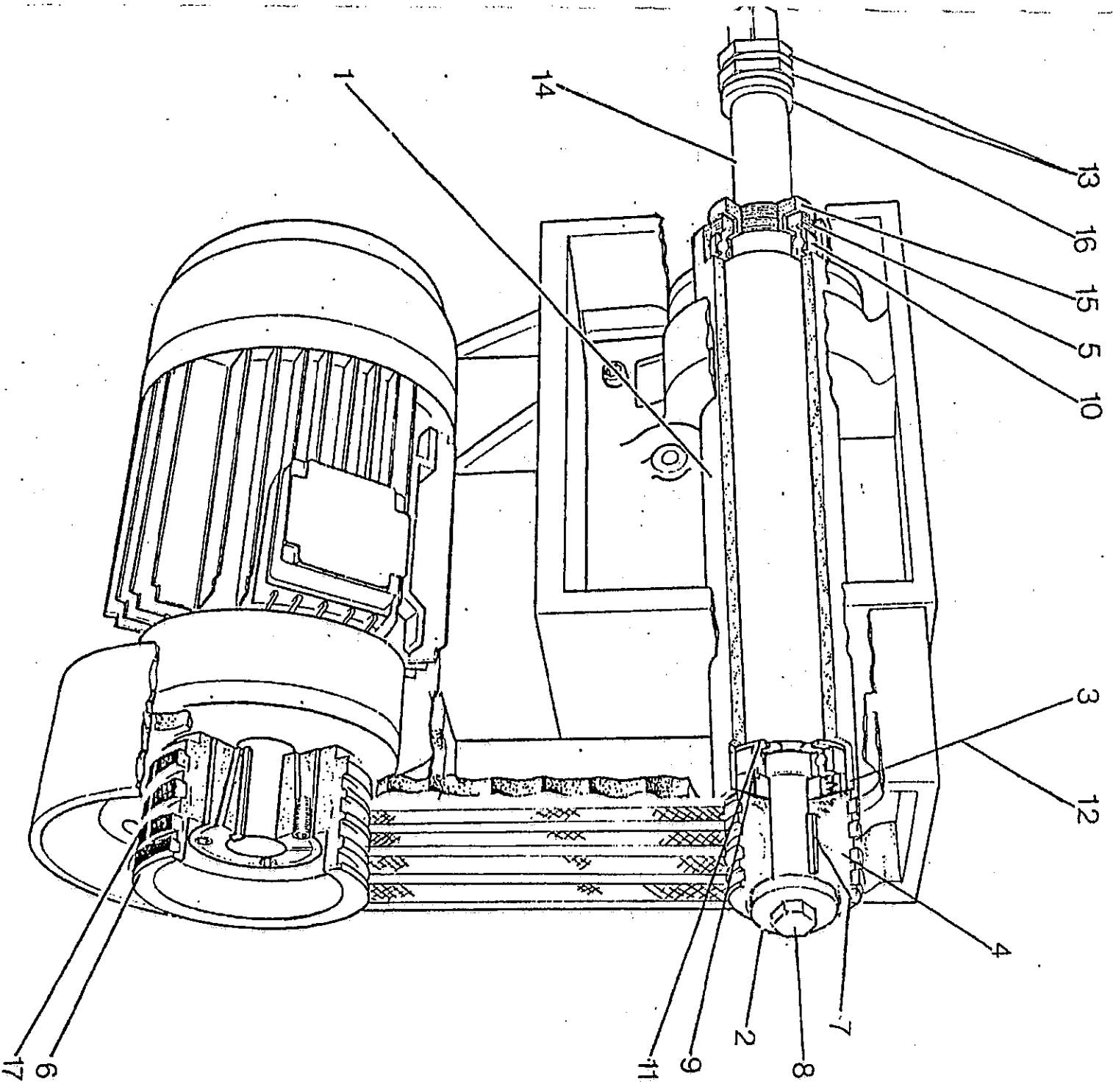

HORIZONTAL CUTTERBLOCK BELT DRIVEN SPINDLE 40mmDia. 6000rpm

FIG 16

ALWAYS QUOTE MODEL AND MACHINE NUMBER WHEN ORDERING SPARES

170B - SECOND BOTTOM HEAD CUTTERBLOCK BELT DRIVER SPINDLE - 40mm. DIA.  
(50HZ) DRIVE MOTOR - 6000 RPM.

SECTIONS C37 C57  
C41 C62

| REF. NO: | DESCRIPTION  | NO:OFF |
|----------|--|--------|
| 1        | Spindle barrel   | 1      |
| 2        | Washer   | 1      |
| 3        | Spacer for pulley seal                                       | 1      |
| 4        | Spindle pulley   | 1      |
| 5        | Bearing locknut and grease retainer                          | 1      |
| 6        | Motor pulley   | 1      |
| 7        | Key 12mm. x 8mm. x 50mm.                                     | 1      |
| 8        | Hexagon head screw M12. x 35mm.                              | 1      |
| ∅ 9      | 7209 TAU EP7 RHP bearing                                     | 1      |
| ∅ 10     | 7011 TAU EP7 RHP bearing                                     | 1      |
| 11       | Disc spring for bearing 6209                                 | 4      |
| 12       | 170mm. x 85mm. x 10mm. labyrinth seal                        | 1      |
| 13       | Spindle locking nut M35.                                     | 2      |
| 14       | 40mm. dia. <del>top</del> <sup>2nd bottom</sup> head spindle | 1      |
| 15       | Ball bearing locknut - <del>right</del> <sup>left</sup> hand | 1      |
| 16       | 35mm. dia. washer  | 1      |
| 17       | Wedge belts "FENNER" SPZ 1600                                | 4      |

∅ "KLUBER" grease packed

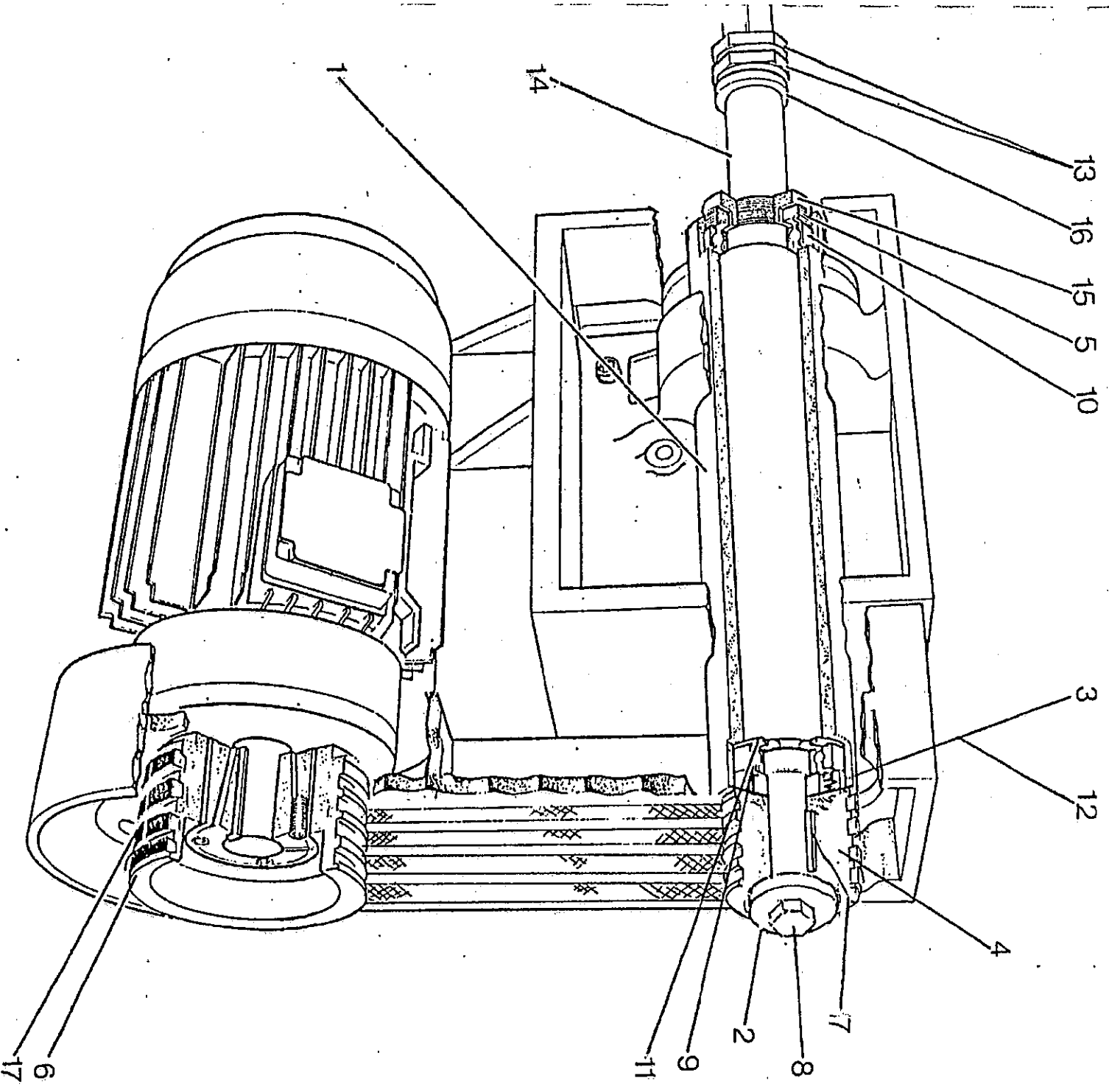

HORIZONTAL CUTTERBLOCK BELT DRIVEN SPINDLE 40mmDia. 6000rpm

FIG 17

ALWAYS QUOTE MODEL AND MACHINE NUMBER WHEN ORDERING SPAPES

UNIVERSAL HEAD - ADJUSTING MECHANISM

| REF.NO: | DESCRIPTION   | NO:OFF |
|---------|---|--------|
| 1       | Universal head spindle 40mm. dia. square shoulder               | 1      |
| 2       | Locking nut   | 1      |
| 3       | Locking collar assembly   | 1      |
| 4       | Traverse screw for vertical movement                            | 1      |
| 5       | Calibrated dial for traverse screw                              | 1      |
| 6       | Vertical slide stand  | 1      |
| 7       | Male "BRISTOL" type "KIP" handle M10. x 50mm.                   | 1      |
| 8       | Saddle for universal head                                       | 1      |
| 9       | Calibrated dial for traverse screw                              | 1      |
| 10      | Traverse screw for horizontal movement                          | 1      |
| 11      | Cross slide for universal head                                  | 1      |
| 12      | Worm gear shaft   | 1      |
| 13      | D.112 OR D.132 Electric Motor                                   | 1      |
| 14      | See page 44 } Pulley  | 1      |
| 15      | See page 44 } Belts   | 1      |
| 16      | GA 363 OR GA 42 Pulley belt housing to suit size of motor       | 1      |
| 17      | GA 360 OR GA 37 Pulley belt housing cover to suit size of motor | 1      |
| 18      | Spindle carriage for universal head                             | 1      |
| 19      | Bolt for spindle carriage                                       | 1      |
| 20      | Bolt for spindle carriage                                       | 1      |
| 21      | Worm wheel for universal head                                   | 1      |

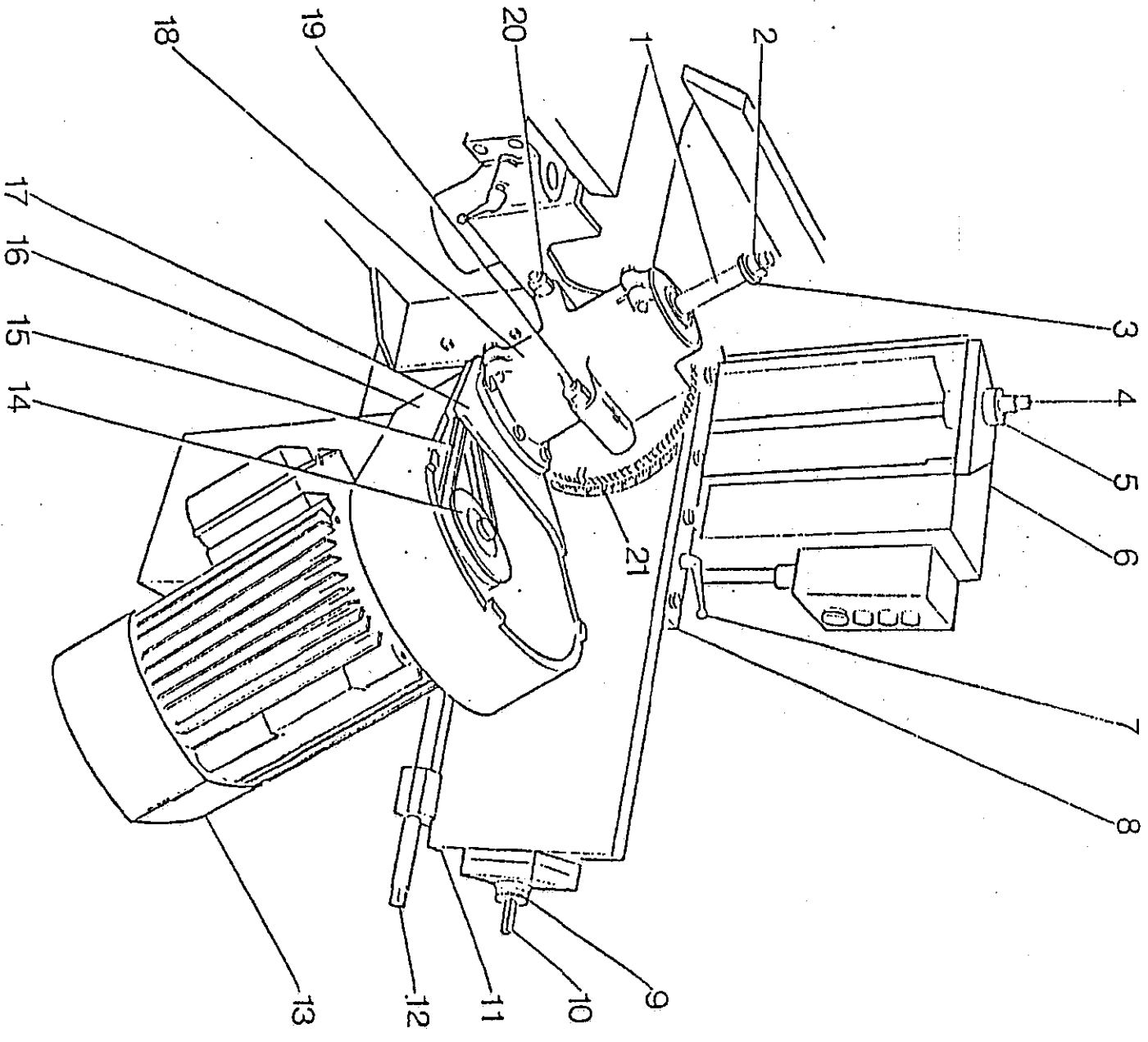

UNIVERSAL HEAD ADJUSTING MECHANISM

FIG 18

ALWAYS QUOTE MODEL AND MACHINE NUMBER WHEN ORDERING SPARES

UNIVERSAL HEAD SPINDLE 40mm. DIA. SQUARE SHOULDER

SECTION GA E08

| REF. NO: | DESCRIPTION   | NO: OFF |
|----------|---|---------|
| 1        | Locking nut for fence side head, top head and universal head spindles               | 1       |
| 2        | Locking collar assembly for 40mm. dia. universal head spindle                       | 1       |
| 3        | Supplied as a complete unit   | 1       |
| 4        |   |         |
| 5        | Bearing nut for fence side head, top and universal head spindles                    | 1       |
| 6        | Bearing nut for spindle housing   | 1       |
| ∅ 7      | R.H.P. OR SKF. bearing 6009   | 1       |
| 8        | Barrel for universal head spindle   | 1       |
| 9        | "BELLEVILLE" SERIES 'K' disc spring for bearing 6306<br>71.5 O.D. x 45.5 I.D. x 0.7 | 6       |
| ∅ 10     | R.H.P. OR SKF bearing 6306  | 1       |
| 11       | Pulley spigot for spindle   | 1       |
| 12       | M12. x 45mm. long hexagon head screw  | 1       |
| 13       | 8mm. x 7mm. x 40mm. long key  | 1       |
| 14       | 40mm. dia. square shoulder universal head spindle                                   | 1       |

∅ "KLUBER" grease packed

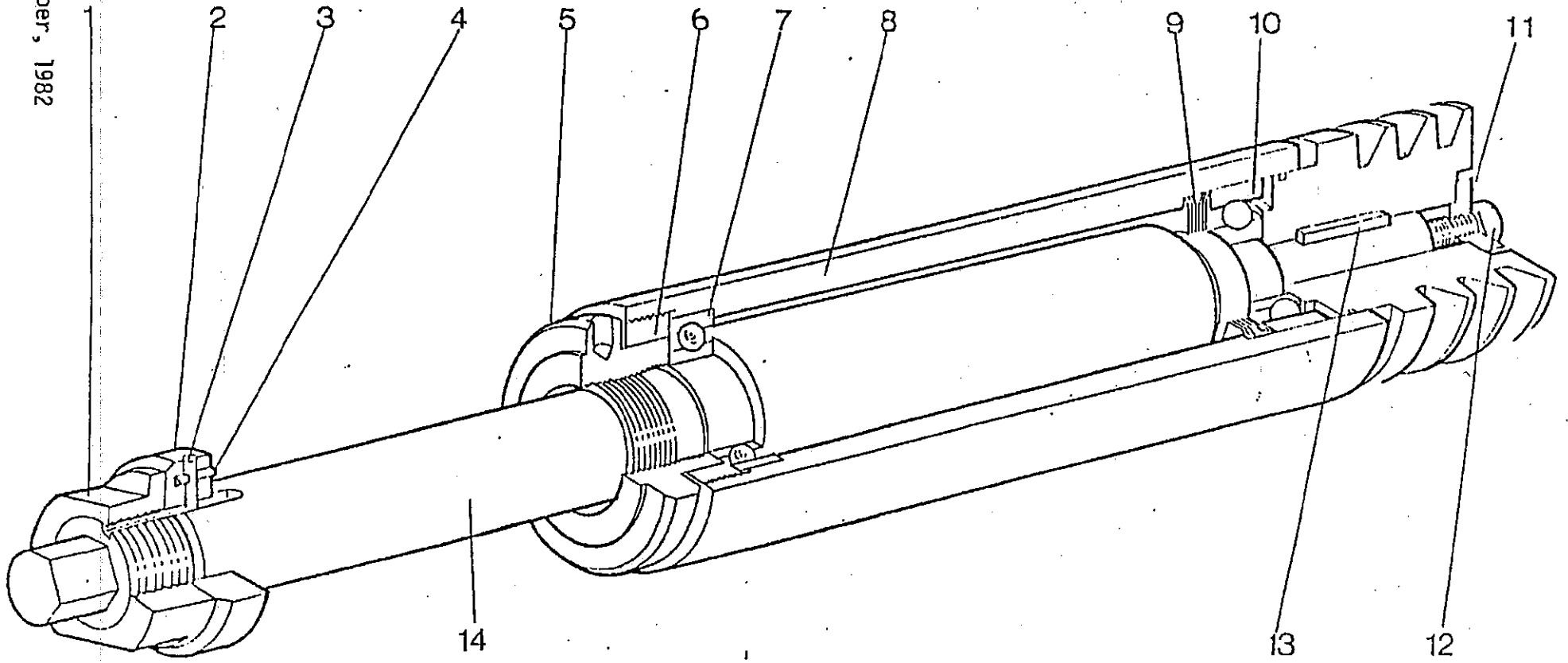

FIG 19

UNIVERSAL HEAD SPINDLE 40mm DIAMETER SQUARE SHOULDER

BELTS AND PULLEYS FOR MACHINES HAVING AN ELECTRICAL FREQUENCY OF 50 HERTZ

| HEAD      | SPEED RPM. | MOTOR SIZE AND OUTPUT                         | "FENNER" BELT REF.         | MOTOR                   |                                       | CUTTER SPINDLE |                          |
|-----------|------------|---|----------------------------|-------------------------|---------------------------------------|----------------|--------------------------|
|           |            |   |                            | PULLEY REF.             | "FENNER" TAPER LOCK BUSH              | PULLEY REF.    | "FENNER" TAPER LOCK BUSH |
| UNIVERSAL | 6000       | D112 4.0KW 5.5HP                              | SPZ 940 2off<br>K30 77 156 | 031Z 0222<br>K30 78 237 | BUSH 2012<br>BORE 28mm.<br>K30 78 237 | GA 109         | -                        |
| UNIVERSAL | 6000       | D132 5.5KW 7.5HP<br>7.5KW 10HP<br>11.0KW 15HP | SPZ 940 3off<br>K30 77 156 | 031Z 0223<br>K30 78 218 | BUSH 2012<br>BORE 38mm.<br>K30 77 113 | GA 410         | -                        |

BELT AND PULLEYS FOR MACHINES HAVING AN ELECTRICAL FREQUENCY OF 60 HERTZ

|           |      |   |                            |                         |                                       |        |   |
|-----------|------|---|----------------------------|-------------------------|---------------------------------------|--------|---|
| UNIVERSAL | 6000 | D112 4.0KW 5.5HP                              | SPZ 900 2off<br>K30 78 351 | 031Z 0202<br>K30 78 296 | BUSH 1610<br>BORE 28mm.<br>K30 77 184 | GA 109 | - |
| UNIVERSAL | 6000 | D132 5.5KW 7.5HP<br>7.5KW 10HP<br>11.0KW 15HP | SPZ 900 3off<br>K30 78 351 | 031Z 0203<br>K30 78 272 | BUSH 2012<br>BORE 38mm.<br>K30 77 113 | GA 410 | - |