



ULTRACARE
At the Cutting Edge of Industry

24"BAJ

**HIGH SPEED PLANER
AND THICKNESSER**

OPERATING & MAINTENANCE MANUAL

24" HIGH SPEED PLANER & THICKNESSER

TYPE BAJ

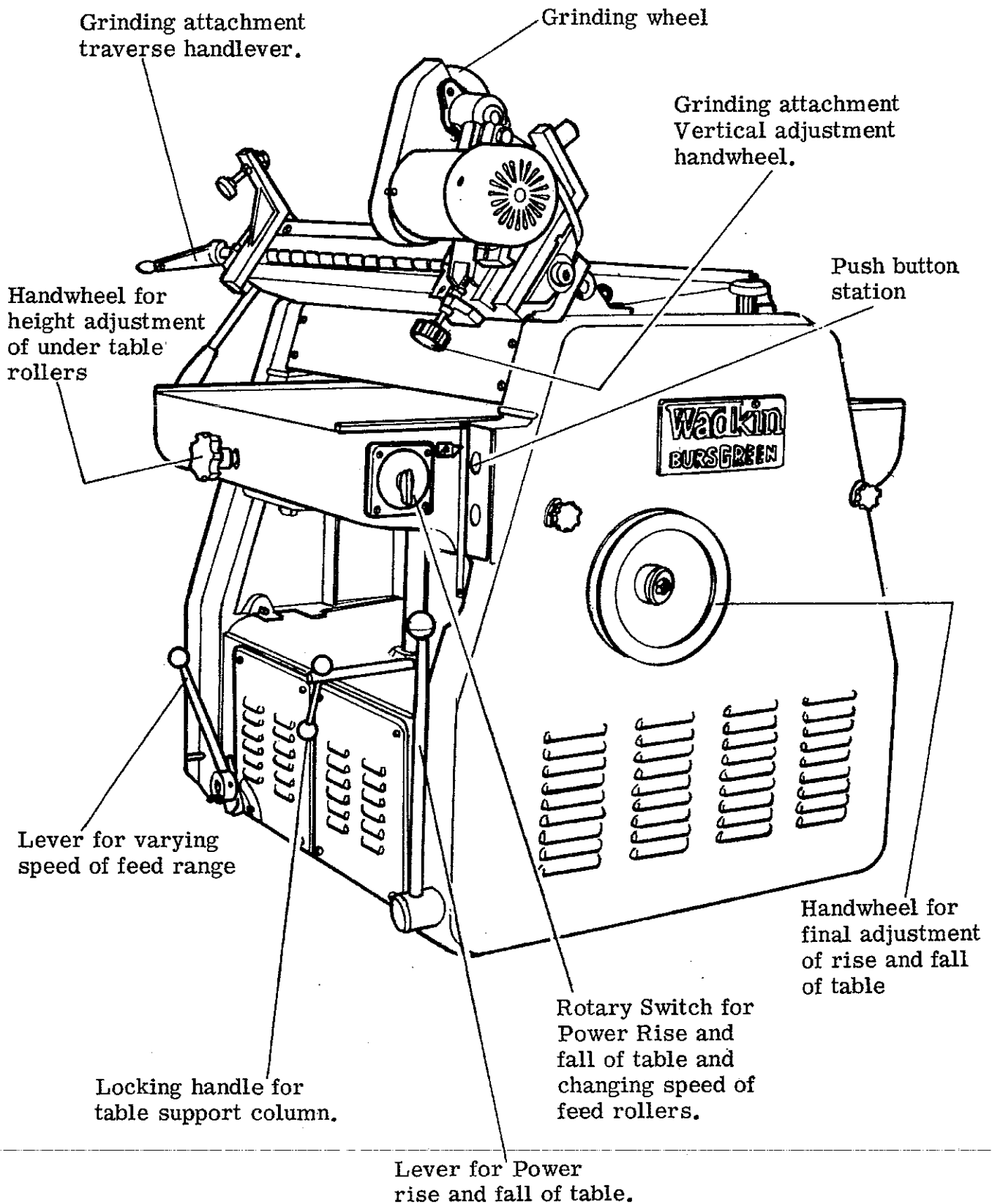

SPECIFICATION

Capacity of Machine	24" x 9"	610 x 230mm
Length of thickening table	44"	1120mm
Rise and Fall of Table	9"	230mm
Speed of cutterblock	4,600 rpm	4,600tpm
Speed of motor : 50 cycles	3,000rpm	3,000tpm
60 cycles	3,600rpm	3,600tpm
Cutting circle of cutterblock	5' 2"	132mm
Diameter of feed rollers	3"	75mm
Width of sections of infeed roller and chipbreaker	1.5/8"	41mm
Feed speeds, per minute	30-100ft	9 - 30m
Horsepower, cutterblock motor		
3 phase supply standard	10HP	
optional extra	15HP	
Horsepower, two speed feed motor,		
3 phase supply	1HP	
Horsepower of grinding motor	1/2HP	
Size of grinding wheel	6" dia x 1/4" wide	152mm x 6mm
Size of grinding wheel arbor	5/8"	16mm
Speed of grinding wheel	3,000rpm	3,000tpm
Net weight (Approx)	2,400 lb	1090 kg
Gross weight (Approx)	2,600 lb	1180 kg
Shipping dimensions	70 cu.ft.	2.0m ³
Floor space	46" x 43"	1170 x 1100 mm

Installation

Remove protective coating from all bright parts by applying a cloth soaked in paraffin, turpentine or other solvent.

Wiring Details

The motor and control gear have been wired in before despatch. All that is required is to connect the power supply to the starter or isolator when fitted.

Points to note when connecting to power supply:-

1. Check that the voltage, phase and frequency correspond to those on the motor plate also the correct coils and heaters are fitted to the starter.
2. It is important that the correct cable is used to give the correct voltage to the starter as running on low voltage will damage the motor.
3. Check the main line fuses are of the correct capacity. See list below. When an isolator is fitted these are correct as received.
4. Connect the line leads to the appropriate terminals. See fig. 1 for 3 phase supply.
5. Check all connections are sound.
6. Check the rotation of the motor for correct direction. If this is incorrect, reverse any two of the line lead connections.

Voltage	Phase	Cycle	HP	S. W. G. Tinned Copper Wire	Amps
220	3	50	10/1/0.5	18	30
380/420	3	50	10/1/0.5	21	16
208/220	3	60	10/1/0.5	19	28
550	3	60	10/1/0.5	24	13
220	3	50	15/1/0.5	17	42
380/420	3	50	15/1/0.5	19	23
208/220	3	60	15/1/0.5	17	42
550	3	60	15/1/0.5	21	18

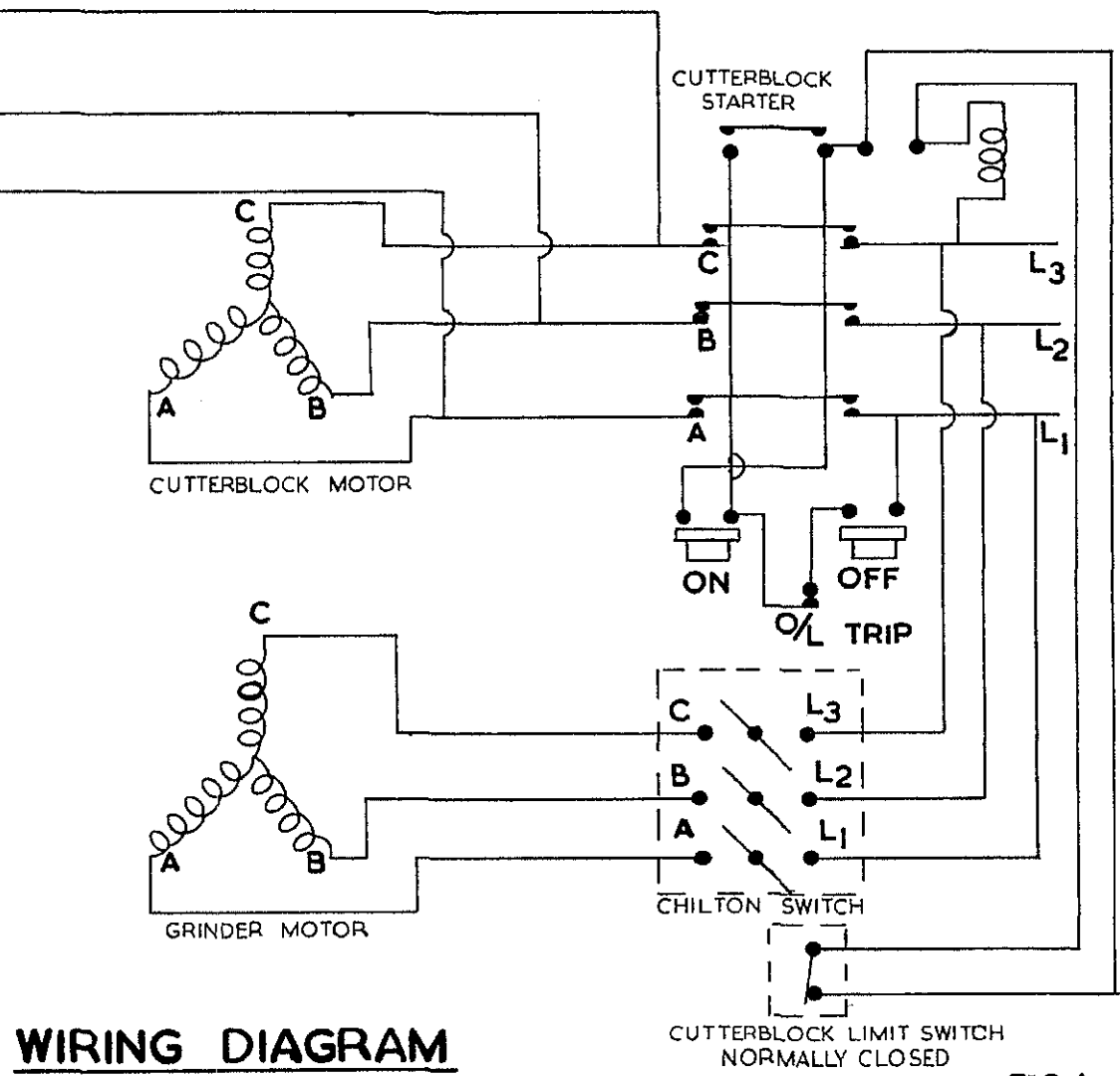
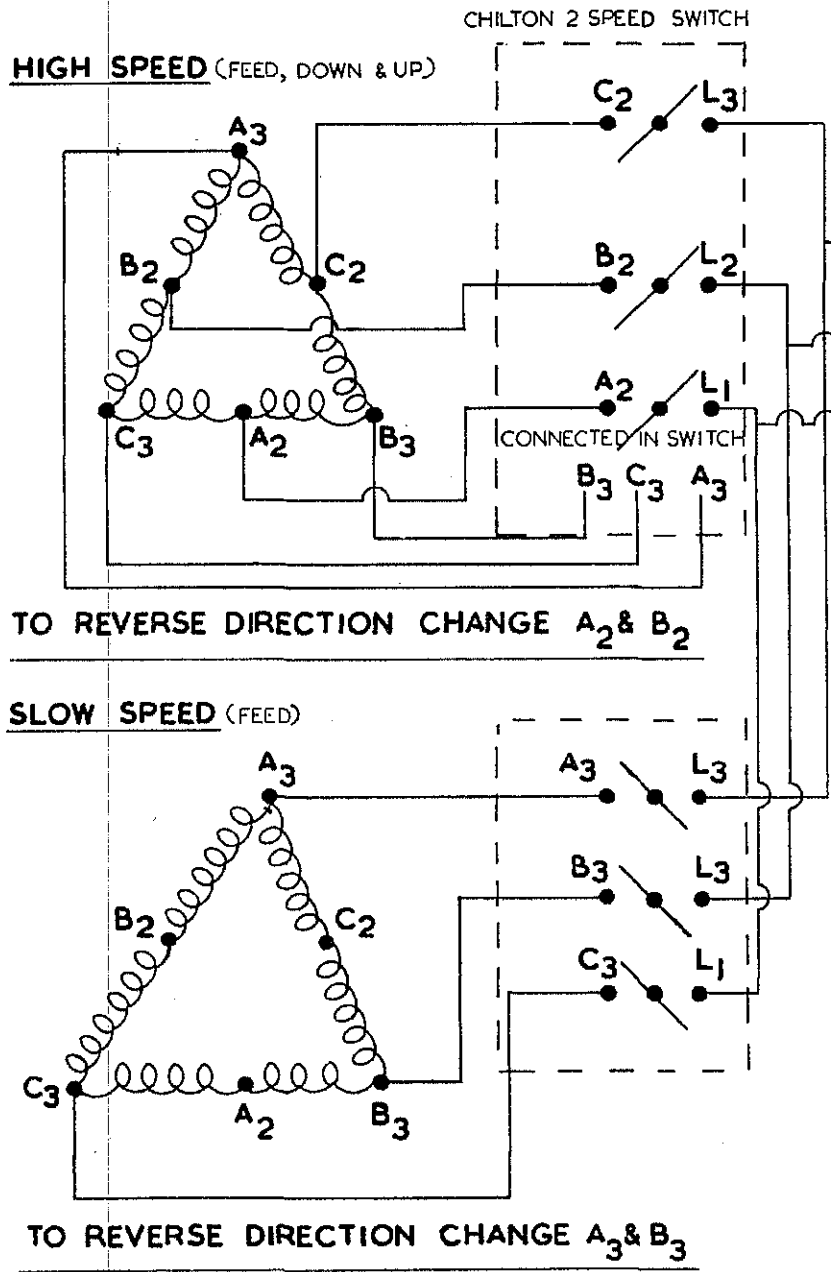

WIRING DIAGRAM

FIG 1.

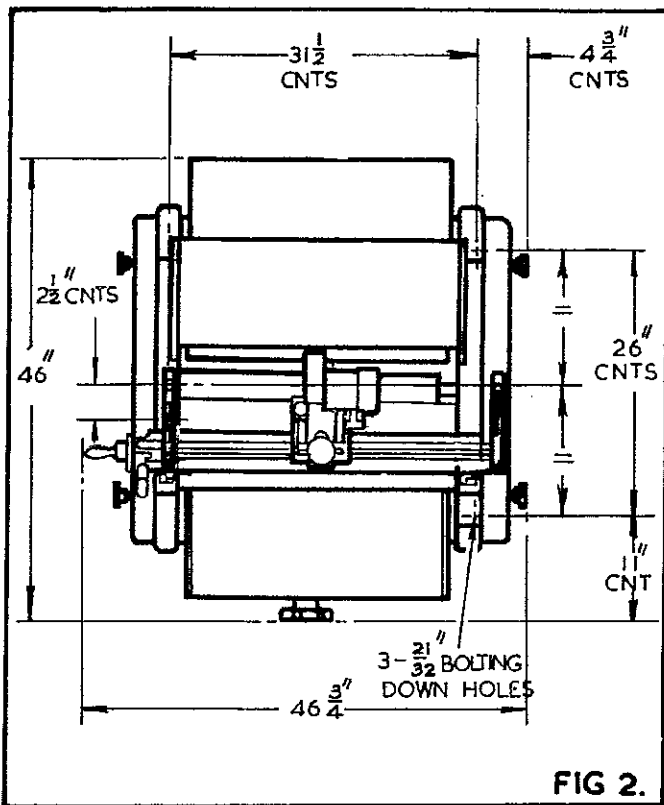

FIG 2.

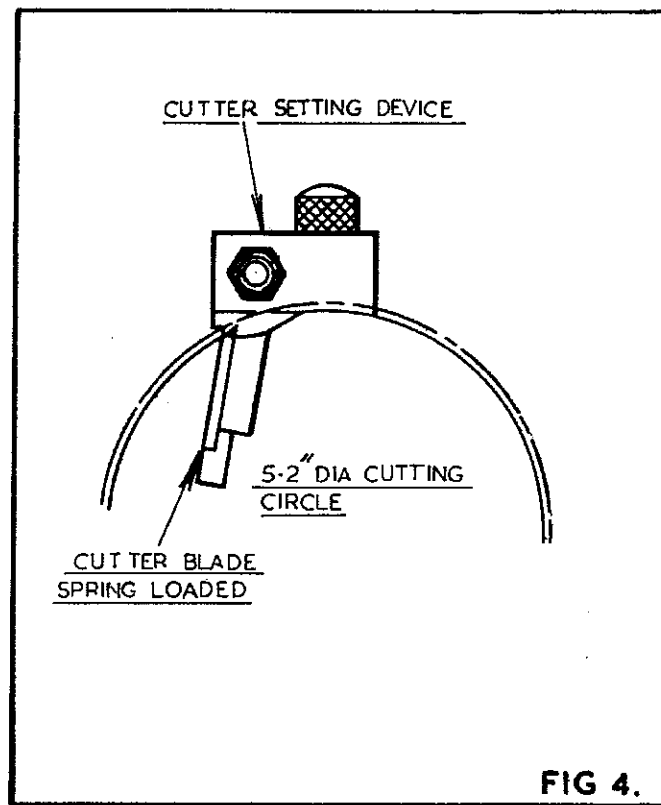

FIG 4.

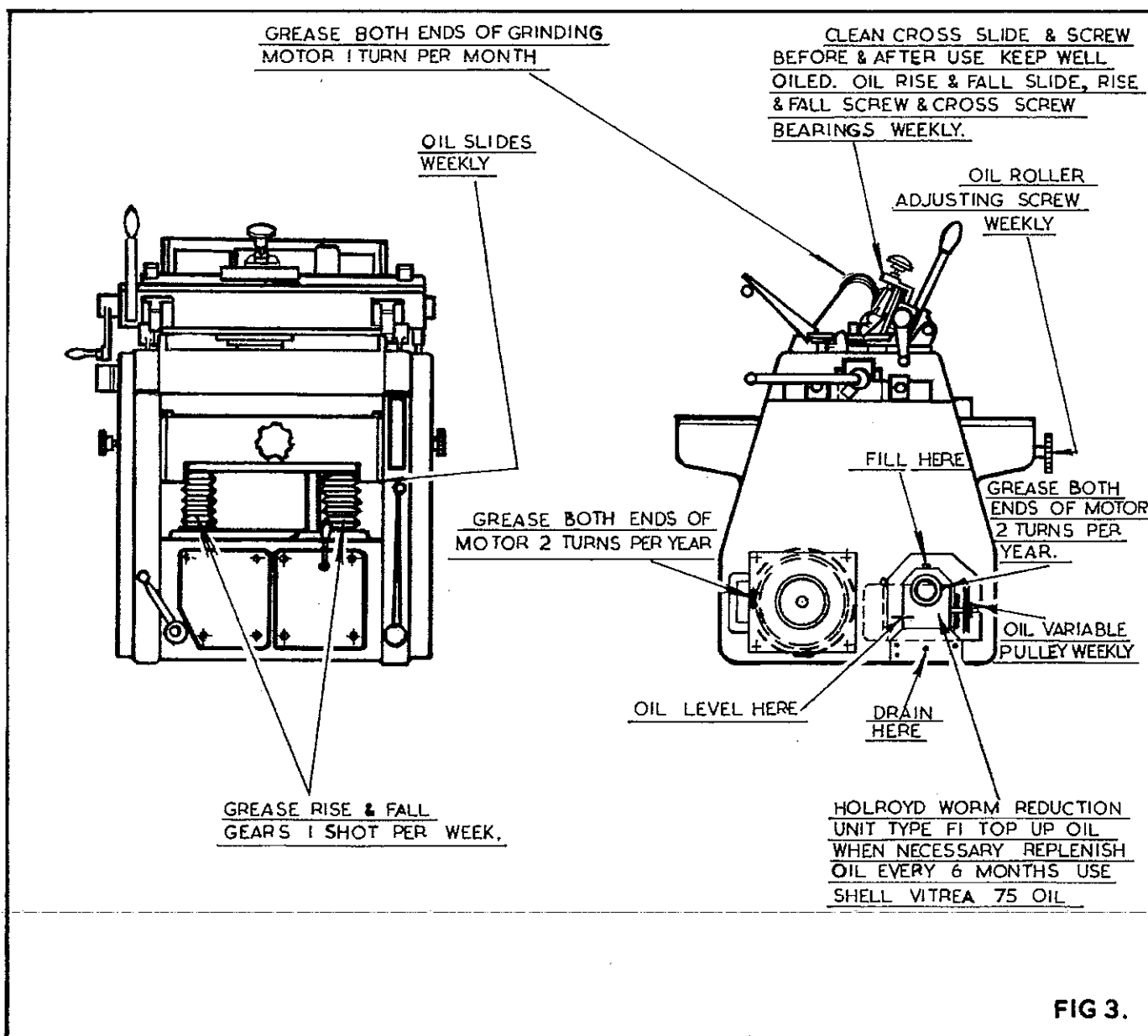

FIG 3.

Lubrication

It is advisable to keep all bright parts covered with a thin film of oil to prevent rusting. See Fig. 3.

TYPE OF OIL RECOMMENDED	POWER EM 125 (For general purposes)
TYPE OF OIL RECOMMENDED	SHELL VITREA 75 (For gearbox)
TYPE OF GREASE RECOMMENDED	SHELL ALVANIA 3.

Foundation

See Fig. 2 for bolt positions and clearances required.

Foundation bolts are not supplied with the machine except by special order.

Belt Tension

The cutterblock drive is by 3 vee belts from a 10 HP motor. To tension the belts remove the drive side panel and loosen the 4 hexagon head bolts securing the motor mounting plate to the side frame. Move the plate down the slots until the correct tension is reached. When set re-lock the hexagon head bolts.

Replace side panel before operating machine.

Feed Chain Tension

Drive to the feed rollers is by roller chain from a two speed motor and reduction gearbox, giving feed speeds of 30 to 100 ft. per minute (9-30m per min.)

It should be noted that the feed chain must run with sufficient slack to allow the front serrated feed roller to freely lift 3/8" (10mm) from the rest position. To adjust, remove drive side panel and loosen the two hexagon nuts securing the jockey sprocket arm to the side frame and adjust until the required tension is reached. Care must be taken to ensure 3/8" (10mm) lift to infeed roller. When set re-lock hexagon nuts.

Replace side panel before operating machine.

Thicknessing Table Rise and Fall Controls

The thicknessing table rises and falls on slides and screws controlled through skew gears and chain drive from the conveniently placed handwheel to the right of the thicknessing table. The table is also fitted with power rise and fall which is operated by the lever on the side frame to the right of the table. The table can be locked in any position by the toggle lever under the table.

The finished thickness of the timber is clearly shown on the rule, on the right hand side frame and indicated by a pointer.

Thicknessing table rollers

The anti-friction table rollers or bed rollers revolve on sealed for life ball bearings and require no lubrication. These are adjustable simultaneously by means of the handwheel at the infeed end of the thicknessing table. Turning the handwheel in a clockwise direction increases the height of the rollers above the table surface.

In all cases the lowest position consistent with good and regular feeding should be used as this will give the best possible results. Should the table rollers be removed for any reason care must be taken to replace them exactly as before otherwise the settings will be disturbed.

It must be emphasised that a really good surface finish from a thicknessing machine is only possible when the face of the timber resting on the machine table is flat and has a reasonable finish. Wherever practicable this face should be pre-machined on an over-hand jointer or surfacer to remove twist and other irregularities.

Also to assist feeding the under table rollers should be cleaned at regular intervals of resin, etc which tends to build up and thus create an eccentric rolling action to the rollers which in turn give inaccurate and jerky feeding to the timber.

Adjusting bed rollers

It is most important that the bed rollers are parallel to the thickening table at all times to ensure good feeding. Should the bed rollers be disturbed for any reason and are incorrectly aligned to the thickening table the undermentioned procedure should be followed.

1. Clear thickening table of all chippings etc and place a straight edge over both rollers to one side of the table.
2. Check the straight edge is parallel throughout the length of the table, also check the bed rollers are parallel across the width of the table.
3. To adjust the height of the bed rollers raise the thickening table to approximately the top position and adjust the 4-3/8" whit hexagon head bolts and nuts on the underside of the thickening table directly below each end of the bed rollers.

When bed rollers are correctly set ensure all bolts are securely locked in position.

Feed Roller & Pressure Bar Settings

These are pre-set at the works in accordance with the details given in Fig. 5. and vertical adjustment relative to the cutterblock is neither possible nor necessary provided the cutters are correctly set with the special gauge supplied with the machine.

Should replacement feed rollers or pressure bars be fitted at any time the settings should be very carefully checked with those given in Fig. 5.

Some slight advantage in finish or feed on occasions can be obtained by increasing or decreasing the tension of the pressure bar or feed roller springs.

The springs should never be compressed to a point where the feed rollers and pressure bar cannot lift sufficient to allow the maximum cut to be taken.

Feed Drive Control

The drive between the 1 horsepower two speed motor and reduction gearbox is by vee belt and variable pulley to obtain the feed speeds of 20 to 60ft per minute (6-18 m. per minute.) The speed of the motor is selected by the rotary switch which is positioned on the right hand side of the thickening table. This also determines the direction of the power drive to the table. The motor is movable on a pivot by means of the lever on the left hand side frame. It should be noted that the machine should be run through the range of feed speeds daily to ensure the variable pulley is working efficiently.

Cutter Setting

The cutters are held in the cutterblock by a steel clamping bar secured with 9 - 1/2" whit heat treated socket head screws. When the locking screws are released the cutter is ejected slightly by small leaf springs. This is to facilitate easy setting with the special gauge supplied. This sets the cutters to 5.2" (132mm) cutting circle diameter and should any other method of cutter setting be employed the amount of cutter projection must correspond to that given by the setting gauge supplied.

Note:-

It is important that hexagon socket in the knife locking screws is kept clear of all gum and dirt to ensure easy removal of screws when changing knives.

Always ensure that the hexagon key is fully inserted in the screw when locking or unlocking the cutters. This avoids damage to the hexagon sockets.

Periodically examine screws for damage or cracks particularly in the hexagon hole. Any doubtful screws should be replaced and all screws well lubricated with "Molyslip" or similar oil, before replacing.

To remove cutters and re-set with "Bursgreen" cutter setting gauge proceed as follows:-

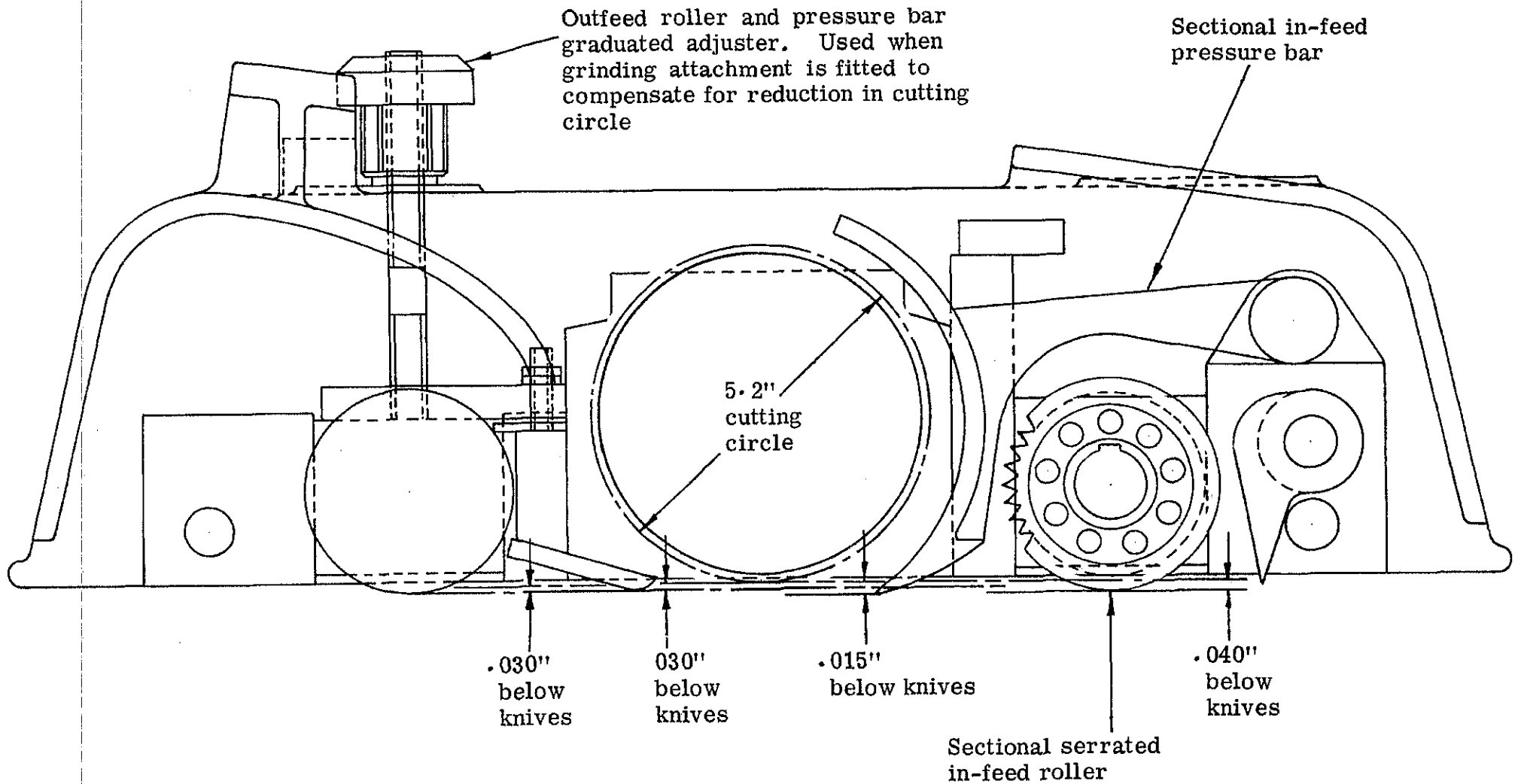

FEED ROLLER & PRESSURE BAR SETTINGS

FIG 5.

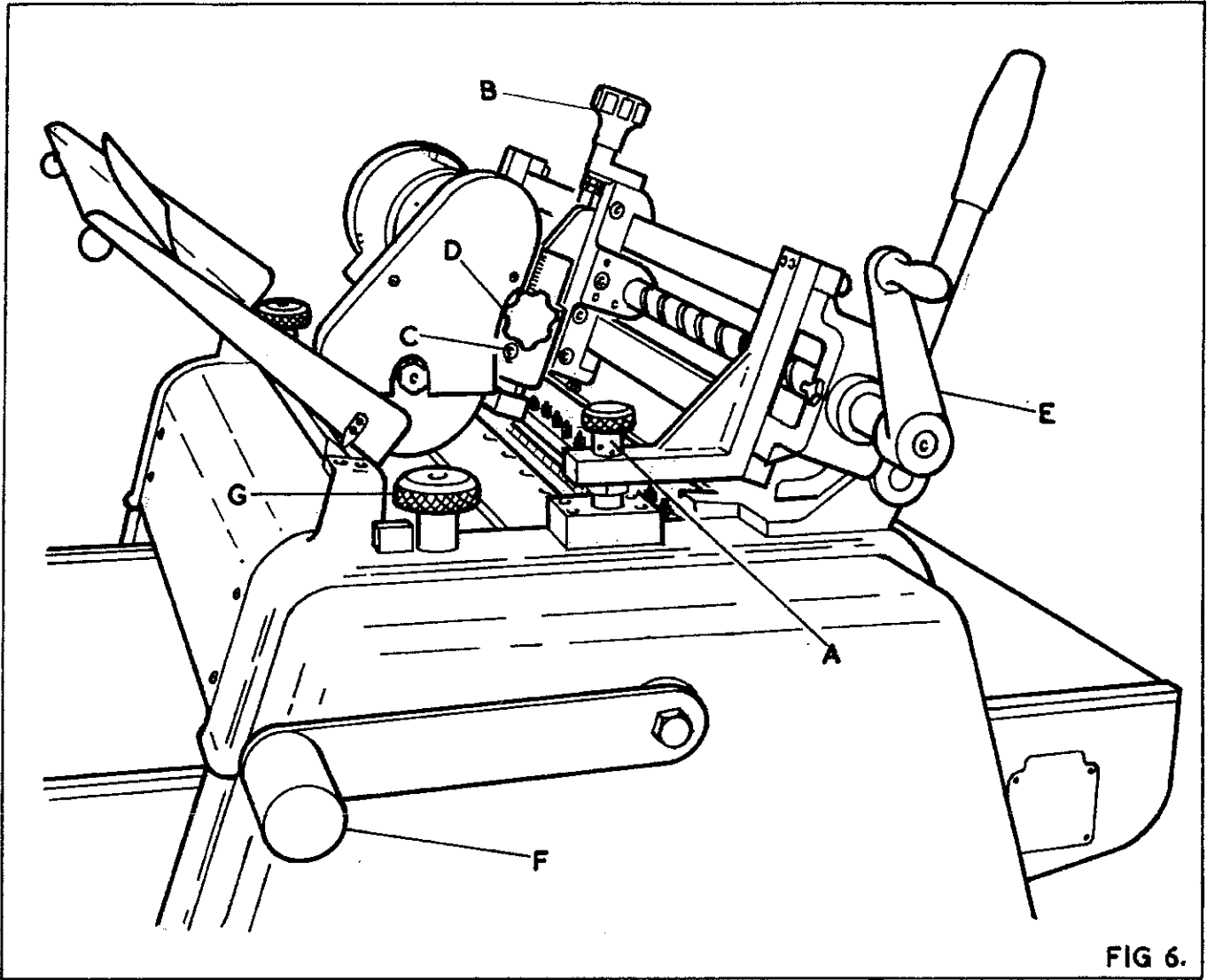

FIG 6.

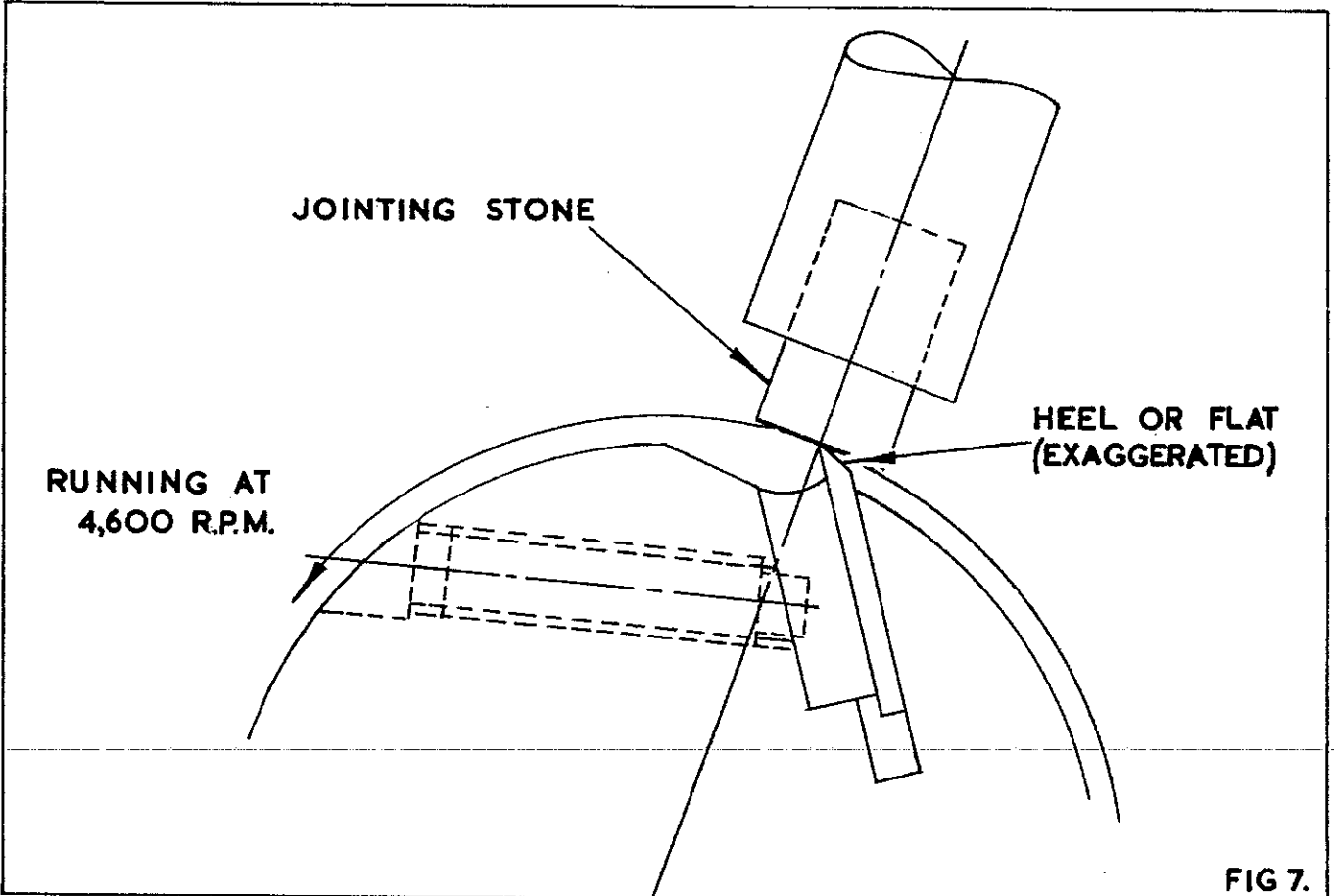

FIG 7.

1. Lift the cutter guard clear of the cutterblock and swing to the rear of machine.
2. Turn cutterblock to a position suitable for access to securing screws. Slacken the securing screws until the knife is just free of the cutterblock. Care should be taken when loosening the last screw as the knives are spring loaded.
3. To re-set the knives. Place the knife in the slot making sure that all faces are clean and the clamping bar free from burrs. Press the knife into the cutterblock and lock the setting device to the cutterblock body with the knurled headed screws supplied until the predominant pads rest on the cutterblock body as shown in Fig. 4. Position the knife central in the cutterblock.
4. Tighten the securing screws. The cutting edge will now be parallel to the cutterblock body and the thickening table.
Check all securing screws have been fully tightened before proceeding to set the rest of the knives.

Jointing

When the setting operation has been completed and it is desired to true up all the cutting edges to a greater degree of accuracy by jointing, the undermentioned procedure should be followed:-

1. Lower jointing and grinding attachment into the working position as shown in Fig. 6 and lock knurled screws "A" securely. Care should be taken to ensure the grinding wheel will not foul the cutterblock when the attachment is lowered into position.
2. Raise grinding wheel, by adjusting handwheel "B", to clear the cutterblock. Lower jointing stone by loosening nut "C" and turning handwheel "D" until it is just clear of the knives, lock nut "C" securely.
3. Start the cutterblock running and allow to attain full speed. Slowly traverse attachment across the cutterblock by handle "E" and adjust handwheel "B" until the stone touches the knives and gives off a very light spark. Continue to traverse the attachment backward and forward along the cutterblock and adjust the jointing stone until each knife appears to have been touched. Stop the cutterblock and if correctly jointed a very slight flat or heel, as shown in Fig. 7 will be seen on each knife thus ensuring that all are cutting equally. The jointing operation may be performed two or three times before re-grinding, but never allow a heel greater than 1/32" (.8mm) wide on the bevel. An excessive heel will overload the motor and give a less satisfactory finish.

Grinding

To grind the knives when in position the undermentioned procedure should be followed:-

1. Raise jointing stone by loosening nut "C" and turning handwheel "D" until it is well clear of the knives.
2. Insert weighted lever "F" into aperture in drive side panel. This locates on a hexagon nut on the end of the cutterblock and also operates a limit switch which ensures the cutterblock cannot be started during the grinding operation.
3. Engage index finger under the front of the knife, and insert the weighted lever in approximately the position shown in Fig. 6. It should be noted that the index finger is spring loaded to ensure it is always clear of the cutterblock unless the weighted lever is in the correct position for the grinding operation.
4. Start the grinder spindle and adjust grinder spindle, by means of handwheel "B" to bring the grinding wheel on to the back bevel of the knife. Traverse the grinding wheel across the knife two or three times by means of handwheel "E" and ensure the grinding wheel goes across the full length of the knife.
5. The cutterblock is then rotated clockwise to the next knife, positioned and located by the index finger and ground as set out in item 4.

6. When each knife has been ground individually, grind all the knives at one setting and if necessary lower the grinding wheel and take further cuts on each knife in turn until all the bevels are evenly ground.

7. It is preferable to joint the knives immediately before grinding and then grind to leave the slightest visible heel on each knife. Alternatively the jointing can be carried out after grinding but will probably give a larger heel to start off with than the first method.

After grinding the attachment must be swung back and the weighted lever removed. This will re-set the micro-switch for starting and should automatically release the index finger but it is advisable to check the latter before replacing the cutterblock guard.

It is possible to grind the knives approximately six times before it is necessary to re-set them. This is made possible because the rear pressure bar and feed roller can easily be set to compensate for the reduced cutting circle after re-grinds.

Rear Pressure bar and feed roller adjustment

The rear pressure bar and feed roller are set .030" below cutting circle before despatch. As grinding or jointing operations are performed the rear pressure bar and feed roller must be lifted to compensate for the reduction in cutting circle diameter. This is done by the knurled knobs "G" in Fig. 6 at either side of the machine. If the work tends to stick on the rear pressure bar 1 or 2 notches of the setting knobs "G" will usually be sufficient to release it and maintain an even feed through.

Care should be taken to ensure that each setting knob is set at the same number on the dial. This ensures that the pressure bar and feed roller are parallel to the thickening table at all times.

When the knives have to be reset to the full cutting circle diameter of 5.2" (132mm) the setting knobs must be brought back to their original position i.e. No. 1 on the index.

General Hints

1. When thickening long lengths of timber always support after the machine table, otherwise a step will appear on either or both ends.
2. When a smooth finish is required use a slow feed speed. For roughing when the finish is not important use a fast feed speed.
3. For the best results always feed the timber to cut with the grain.
4. Should the timber stick when thickening probable causes are given below:-
 - a) The table rollers are set too low in table.
 - b) The spring pressure is too great on the pressure bars and too light on the feed rollers
 - c) The timber is too roughly sawn or badly twisted and requires pre-facing.
 - d) The timber may be tapered in its length and thus wedged under the cross tie bar.

SPARE PARTS LIST FOR 24" BAJ

- 1 - Pair H.S.S. planing cutters, 24 $\frac{1}{4}$ " long x 1 $\frac{1}{2}$ " wide x 1/8" thick
- 1 - Cutter setting device
- 1 - Clutch control cable B-1020/11
- 2 - Table R & F clutch discs A-1045/109
- 1 - 6" dia x $\frac{1}{4}$ " wide x 5/8" bore grinding wheel carborundum grade AA60-K5-VF8
- 1 - $\frac{3}{4}$ " dia jointer stone ref No. RJ155

Bearings Used

- Cutterblock bearings :- 3 - Fischer 6208FF sealed for life bearings
- Under Table rollers :- 4 - SKF 6203 2RS sealed for life bearings
- Table R & F screw :- 2 - SKF 010 thrust race
- Table R & F cross shaft :- 2 - SKF 08 thrust race

Grinder Spindle :- 2 - SKF G88503 sealed for life bearings

- 1 - 18½" long x ¼" wide (Flexdon) vee belt
- 3 - Fenner alpha 670 space saver vee belt (cutterblock drive)
- 1 - Fenner alpha 280 vee belt (Special 2 step feed drive)
- 1 - Fenner A30 vee belt (variable feed drive)
- 3 - Fenner alpha 850 space saver vee belt (Special 15HP drive)

Sprockets, Pulleys & Chain for 50 cycle machine

- 2 - 38 tooth feed roller sprocket B-1002/108
- 1 - 38 tooth 1" bore R & F sprocket B-1002/108
- 1 - 25 tooth clutch sprocket B-1045/5
- 1 - 19 tooth jockey sprocket B-1031/59
- 1 - 13 tooth idler sprocket B-1033/233
- 1 - 19 tooth R & F sprocket B-1045/49
- 1 - 36/36 tooth gearbox and feed sprocket B-1045/227
- 1 - Cast iron cutterblock pulley B-1045/24
- 1 - Cast iron cutterblock motor pulley B-1045/25
- 1 - Cast iron gearbox pulley B-1045/121
- 1 - Picador 5" dia Autojust pulley. Fig. 98 1" bore and keyway
- 1 - Picador 6" dia Diecast pulley . Fig. 1A 5/8" bore and keyway gearbox
- 1 - Renolds chain Cat. No. 110046

- Feed roller drive - 90 links including joining link
- Power R & F drive - 30 links including joining link
- Table R & F drive - 33 links including joining link

50 cycle electrics

- 1 - Brooks 10HP motor, cont. rated 3,000 rpm, frame D215, flange mounted, no spigot, star delta wound, 3 phase, 50 cycles
- 1 - Brooks motor, .9/1.1HP. 1, 500 and 3, 000 rpm frame 80b, foot mounted, terminal box standard position
- 1 - Chilton rotary switch Ref. C16. No. 84F443E with RG001 black handle
- 1 - Brook motor "Gryphon" BS42, T. E. F. C. ½HP 30 min. rating 2, 800 rpm foot and face mounted 50 cycle standard terminal box (Grinder motor)
- 1 - Brook start push button unit
- 1 - Brook stop push button unit
- 1 - Burgess limit switch 4CRQR
- 1 - Chilton rotary switch Ref. C. 16 No. 8AF443E with RG001 black handle
- 1 - Chilton rotary switch Ref. C. 16. No. A292

Voltage 380/420/3phase 50 cycles, 10HP 0.9HP D.O.L.

- 1 - MTE UNCO Unit Pack 1 size 5
- 1 - " " " " 2 " 5
- 1 - " " " " 3 " 10
- 2 - " Overload units UOL 1/2
- 1 set - MTE heater elements 11 amps, 95 000 557 000
- 1 set - MTE heater elements 2 2 amps 95 000 555 002

Voltage 380/420/3 phase 50 cycles 10HP 0.9HP Star Delta

- 3 - MTE UNCO Units Pack 1 size 5
- 3 - " " " " 2 size 5
- 3 - " " " " 3 size 10
- 1 - " " " " 4 size 5
- 1 - " " " " 5 size 5
- 1 - " " " " 7 size 10
- 2 - " Overload units UOL 1/2
- 1 set - MTE Heater elements 7.5 amps 95 000 556 006
- 1 set - " " " 2.2 amps 95 000 555 002

Special for 50 cycle machine 15HP Drive

1 - Brook 15HP motor, 3,000 rpm foot mounted frame D254, terminal box at 3 o'clock from driving end

Special for 60 cycle machine

Sprockets, Pulleys & Chains

2 - Feed roller sprocket 38 tooth	B-1002/108
1 - 38 tooth R & F sprocket 1" bore	B-1002/108
1 - 19 tooth jockey sprocket	B-1031/59
1 - 13 tooth idler sprocket	A-1033/233
1 - 25 tooth clutch sprocket	B-1045/5
1 - 19 tooth R & F sprocket	B-1045/49
1 - 36/30 gearbox and feed sprocket	B-1045/277
1 - Cast iron gearbox pulley	B-1045/121
1 - Cast iron cutterblock pulley	B-1045/145
1 - Cast iron cutterblock motor pulley	B-1045/146
1 - Picador 5" dia autojust pulley Fig.98 1" bore and keyway	
1 - Picador 6" dia Diecast pulley Fig.1A 5/8" bore and keyway	

1 - Renolds chain Cat. No.110046

Feed roller drive, 87 links including joining link

Table Power R & F 29 links including joining link

Table hand R & F 32 links including joining link

Special 60 cycle electrics

1 - Brook Kompact motor, 10HP, 3,600 rpm flange mounted, no spigot, frame L215TD, "D" type flange.

1 - Brooks motor 9/1.1HP, 1,800 and 3,600 rpm frame, 80b, foot mounted terminal box standard position

1 - Brook motor "Gryphon" BS42. 1/2HP, 3,400rpm, 30 min rating, foot and face mounted, standard terminal box

60 cycle electrics

1 - Brook start push button unit

1 - Brook stop push button unit

1 - Burgess limit switch 4CRQR

1 - Chilton rotary switch Ref.C.16. No.AG460 with RG001 black handle

1 - Chilton rotary switch Ref.C.16.No.A292

Voltage 550/3phase 60 cycles, 10HP ^{1.1} 0.9 HP

2 - MTE UCO Units pack 1 size 5

2 - " " " " 2 size 5

2 - " " " " 3 size 10

2 - " Overload units UOL 1/2

1 set - MTE Heater elements 7.5 amps 95 000 556 006

1 set - " " " 1 amp 95 000 555 006

3 - English Electric C.30 Fuse, bases and carriers

3 - English Electric HRC Fuses C.S.A. 2 amps

Voltage 208/220 3 phase 60 cycles 10, ^{1.1} 0.9 HP

1 - MTE UCO Unit Pack 1 size 5

1 - " " " " 2 size 5

1 - " " " " 3 size 50

1 - " " " " 1 size 20

1 - " " " " 2 size 20

1 - " " " " 3 size 20

1 - " " " " 8 size 203

- 2 - MTE Overload Units UOL 1/2
- 1 set - MTE Heater elements 25 amps 95 000 559 000
- 1 set - " " " 3-3 amps 95 000 556 003
- 3 - English Electric C30 fuse bases and carriers
- 3 - " " HRC fuses C.S.A. 4 amps

Special for 60 cycle machine 15HP drive

- 1 - Brook Kompact motor 15HP, 3,600 rpm. foot mounted, frame L254T, terminal box at 3 o'clock from driving end

Feed and Table Power Rise and Fall Controls

The feed and table control plate is divided into two separate sections.

1. The table power movement "UP" and "DOWN".
2. The feed speeds "HIGH" and "LOW"

One motor drives both the table rise and fall and the feed works.

To power rise and fall the table, the feed and table control switch must be placed in either "TABLE" "UP" or "DOWN" position. With the locking handle for the table support column loosened the table can now be moved to the required position by operating the lever controlling the powered rise and fall. When desired position is reached the lever can be returned to the neutral position and locking handle relocked.

Note:- When rotary switch is in "TABLE UP" position the feed works revolve backwards but return to correct direction when the switch is moved into the "FEED" section.

The feed speed required can be selected by setting the feed rotary switch to either "HIGH" or "LOW FEED" position. The lever for power rise and fall should not be moved while the rotary switch is in the "LOW" "FEED" position but only moved in conjunction with the rotary switch in either "TABLE UP" or "DOWN" positions. When the machine is not in use the rotary switch can be moved to the "OFF" position

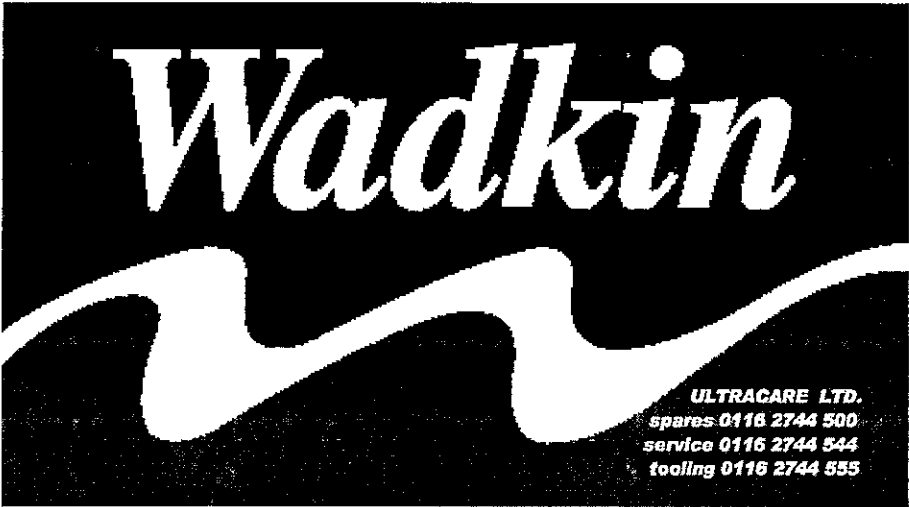

Wadkin

ULTRACARE LTD.
spares 0116 2744 500
service 0116 2744 544
tooling 0116 2744 555