

INSTRUCTION MANUAL FOR

BCVM

Right and left hand pneumatic crosscut
SAWS.

PLEASE INSERT SERIAL NUMBER OF MACHINE

FOR REPLACEMENT PARTS, TOOLS, AND ACCESSORIES CONTACT

BURSGREEN (COLNE) LTD.,

LODGE HOLME,
TRAWDEN, Nr. COLNE,
LANCASHIRE,
BB8 8RB
ENGLAND

TELEPHONE - 0282 865310

TELEX - 635032 (BURCOL G)

Modifications are made to these books from time to time and it is important therefore that only the book sent with the machine should be used as a working manual

LIFTING

BASIC MACHINE UNIT:- THIS UNIT WEIGHS 350 kg AND IS PROVIDED WITH A LIFTING EYE BOLT. ENSURE THIS BOLT IS SCREWED FULLY DOWN BEFORE ATTEMPTING A LIFT (ie)

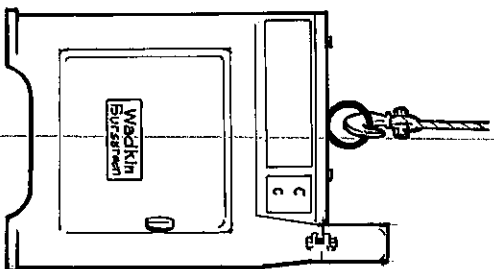

BASIC MACHINE UNIT (CRATED):- WHEN SUPPLIED CRATED FOR EXPORT THIS UNIT WILL WEIGH SOME 400 kg, THE EXACT WEIGHT BOTH NETT AND GROSS BEING INDICATED ON THE BOX. TO LIFT USE EVENLY SPACED BELT OR ROPE SLINGS WHICH ARE KNOWN TO BE IN SOUND CONDITION.

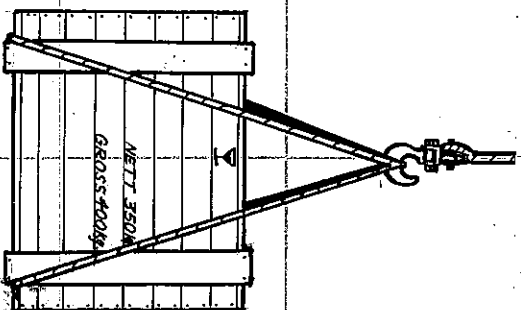

CONVEYOR AND STOP BAR:- THESE UNITS ARE USUALLY SUPPLIED SEPARATE TO THE MACHINE AND CAN WEIGH UP TO 500 kg WHEN CRATED. TO LIFT SUCH UNITS WILL REQUIRE SLINGING AND AS SUCH THE SLINGS SHOULD HAVE A WIDE SPREAD AND SHOULD BE SLUNG FROM A CENTRALLY PLACED HOOK (ie)

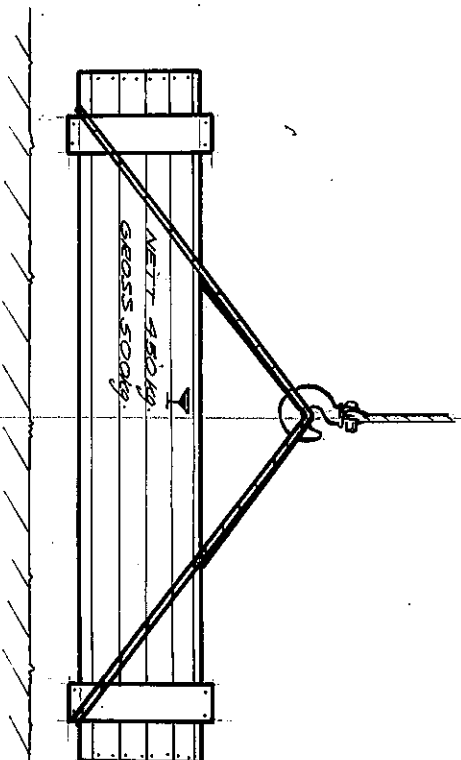

LIFTING NOTES

- 1) WHEN LIFTING WITH ROPE TYPE SLINGS PROTECT AROUND CORNERS OR SHARP EDGES WITH OLD SACKING.
- 2) WHEN USING POWER HOISTS LIFT SLOWLY FROM GROUND LEVEL TO ASCERTAIN STABILITY OF LIFT. A LOAD SHOULD BE RAISED IN THE AIR TO BE SUSPENDED AS LEVEL AS POSSIBLE. IF ON LIFTING THE LOAD SHOWS SIGNS OF TILTING LOWER OFF AND READJUST SLINGS.
- 3) NEVER RAISE A LOAD WITH LOOSE ITEMS UPON IT.
- 4) WHEN MOVING MACHINE OR CRATE TO FOUNDATION POINT VIA OVERHEAD BLOCK OR HOIST, BEFORE MOVING OFF LOWER LOAD DOWN TO WITHIN A COUPLE OF INCHES OFF GROUND LEVEL.
- 5) WHERE LIFTING HOOKS EYE BOLTS OR SPECIAL GRABS ARE PROVIDED ENSURE SUCH FITMENTS ARE SECURED TO THE LOAD BEFORE LIFTING.
- 6) BEFORE USING ANY ROPE, BELT SLING OR CHAINS ENSURE IT IS IN SOUND CONDITION. CUT OR FRAIED ROPES, BELTS OR CHAINS WITH SPRAINED OR SUSPECT LINKS SHOULD NEVER BE USED.
- 7) WHEN OFF-LOADING MACHINE OR CRATE, STAND WELL CLEAR.
- 8) KEEP LOAD STATIONARY WHEN SUSPENDED, DO NOT ALLOW LOAD TO SWING.
- 9) BEFORE LIFTING CHECK MACHINE OR CRATE FOR ANY SPECIAL LIFTING INSTRUCTIONS.
- 10) IF A CRATE IS DAMAGED TO THE POINT WHERE IT IS INSECURE, UNPACK ~~AND LIFT MACHINE ONLY.~~

BCW. LEFT & RIGHT HAND CROSS-CUT SAWS

IMPORTANT:- Throughout this manual reference will be made to RIGHT HAND machines only. However, all sequences (etc.) given apply directly to left hand models also.

The designation LEFT or RIGHT is given to describe the direction of feed (ie) feeding from left to right is a RIGHT hand version, feeding from right to left is a LEFT hand version (ie)

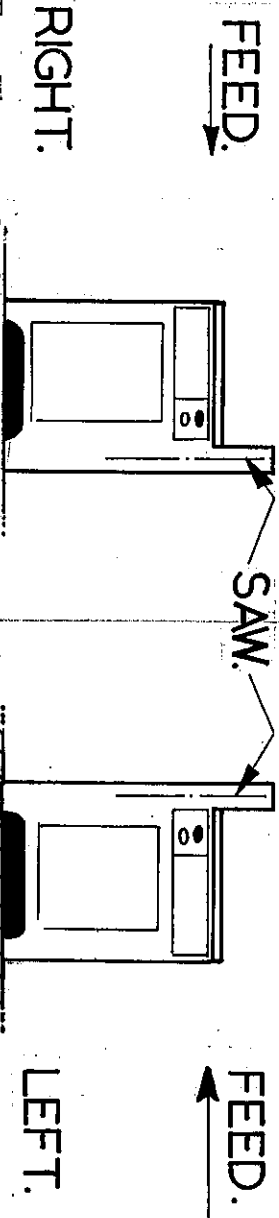

NOTE:- When ordering spares or requesting services please give full serial as shown on machine plate (ie) BCW/R-771234.

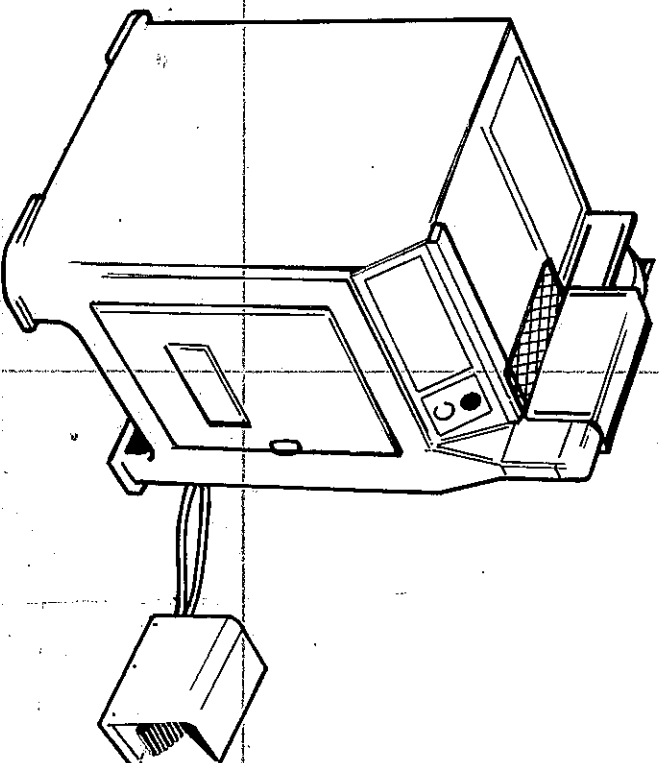
BASIC MACHINE

The basic machine as shown above, consists of the following:-

Saw guards, main saw cylinder, air filter, lubricator, pressure gauge, foot pedal, air isolator, motor, pneumatic and electrical control gear.

FOUNDATION:-

The machine should be levelled via the jacking screws provided on the base feet then bolted down with suitable foundation bolts (not provided) on centres shown (eg) (approximate dimensions)

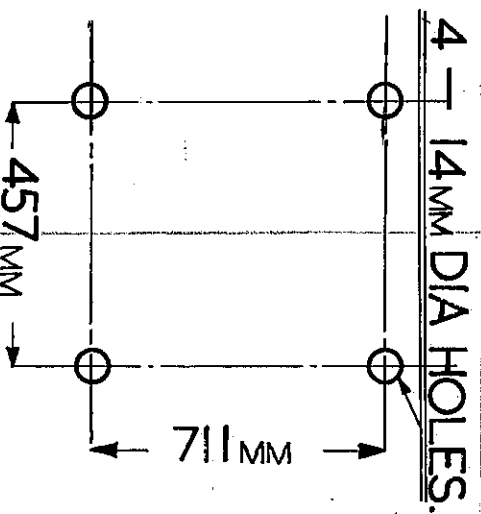

WIRING:-

The following diagram covers standard 3 phase 50 cycles supply. FOR ANY OTHER TYPE OF STARTER SEE SEPARATE DIAGRAM ENCLOSED INSIDE STARTER BOX.

BROOK RT3 STARTER (THREE PHASE)

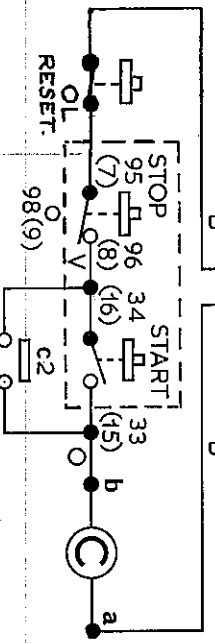
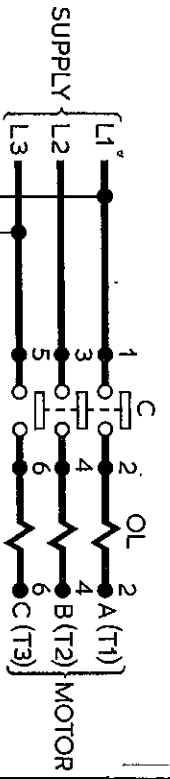
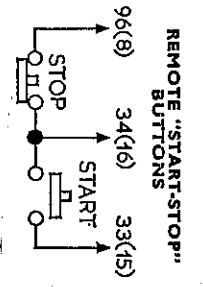
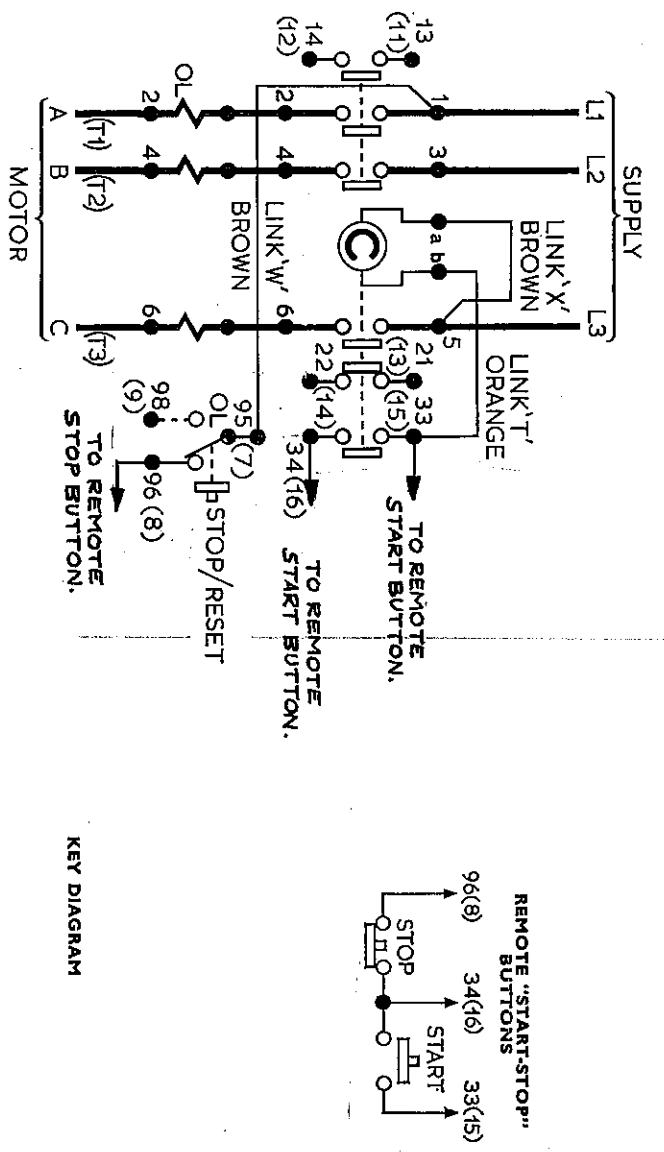

POINTS TO NOTE WHEN CONNECTING TO POWER SUPPLY

1. Check voltage phase and frequency with those on the machine.
2. It is important that the correct cable is used to give the correct voltage to the starter, as running on low voltage will damage motor.
3. Check the main line fuses are of the correct capacity.
4. Connect the line leads to the appropriate terminals (see diagram).
5. Check that all connections are firm.
7. Before fitting saw check spindle runs in correct direction. SPINDLE SHOULD RUN CLOCKWISE ON LEFT HAND MODELS ANTI CLOCKWISE ON RIGHT HAND MACHINES WHEN VIEWED FROM SAW FLANGE SIDE. (1e)

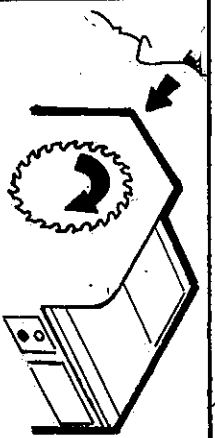
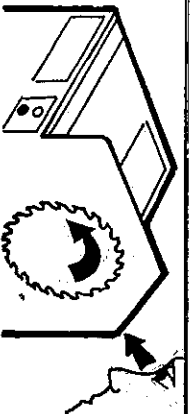

STOPPAGE DURING OPERATION AND FAILURE TO RESTART

1. Fuses have blown.
2. Overloads have tripped. If hand re-set, re-set by pressing button. If automatic they will re-set after a short period.

AIR CONNECTIONS

The foot pedal may be supplied disconnected and should be piped up to the machine with the shortest of the two pipes fitted to the bottom port of the 'T' unit at (point X). The remaining longer pipe should be connected to the bottom port on the manifold (point Y). In all cases these two pipes are 'tagged' and therefore should be connected to their corresponding identification symbol on the 'T' unit and manifold. The main air supply should now be connected to the air isolator adaptor at (point Z) (ie)

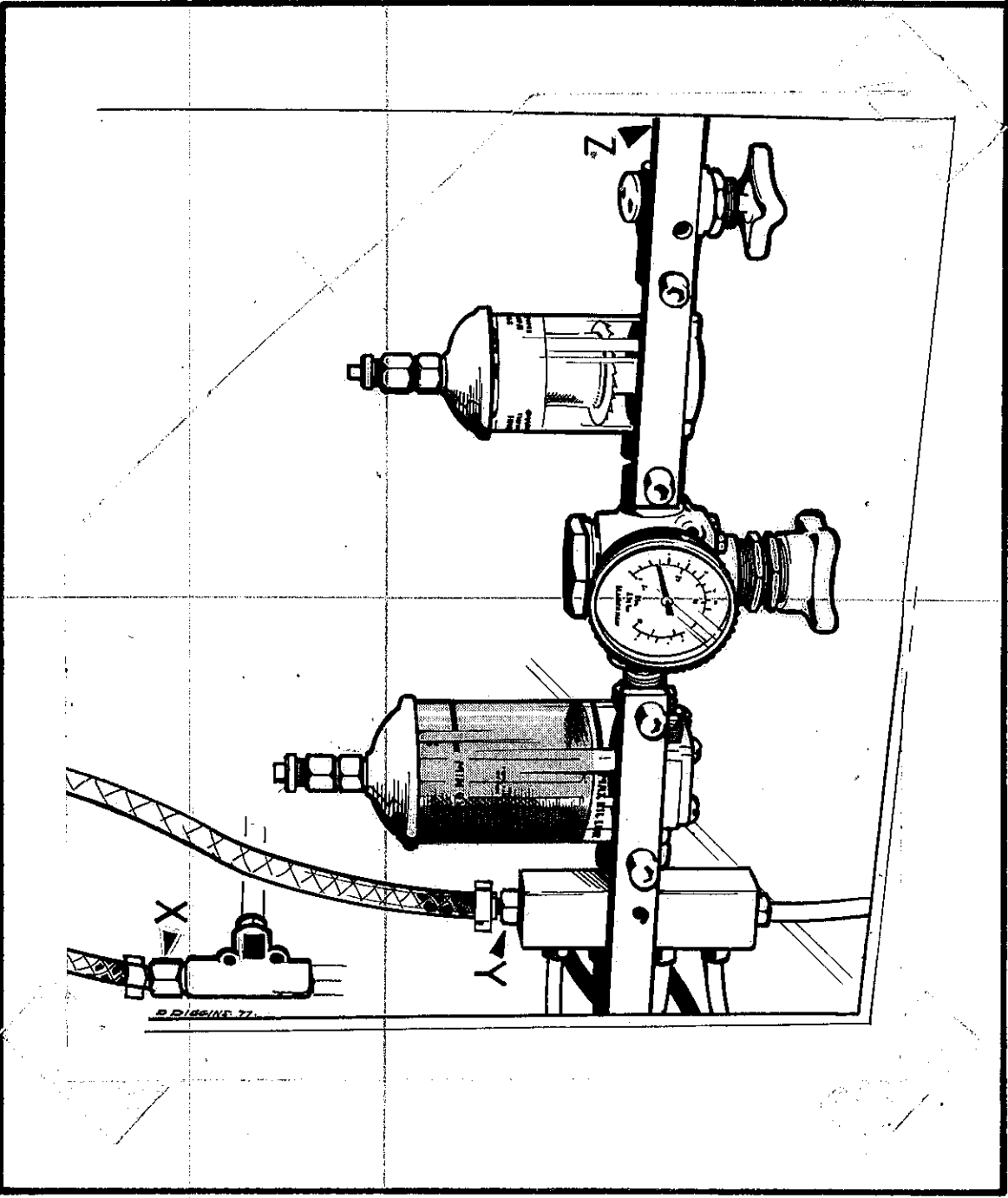

The machine is now connected both pneumatically and electrically and is ready to run. However, checks should be made on the following points before running.

Check oil level in lubricator. (SHELL TELLUS 27)

Check drive belts for correct tension.

It is recommended that the machine be initially run minus a saw, and as such both loose saw flange and nut should be removed from the machine.

Open air tap fully and check that pressure is constant between 80-100 lb/ins'. Depress foot pedal and check action of saw carriage. It

should be noted that a safety valve is incorporated into the air circuit which rules out the possibility of the saw carriage repeating its stroke if the foot is kept depressed on the foot pedal. As such the pedal will have to be released to allow the air system to re-set, allowing the carriage to stroke again.

Start machine checking direction of spindle rotation as previously outlined.

SAWS

IMPORTANT: - WHEN HANDLING SAWS ALWAYS PROTECT HANDS

The diagram below indicates the saw spindle and drive centres. It should be noted that the standard centre bore is 1 1/4" DIA. whilst two further optional spindle diameters can be supplied to order. (ie) 30 mm or 32 mm. It is therefore important that a saw of correct bore is fitted to the machine.

WHEN ORDERING SAWS PLEASE SPECIFY BORE SIZE REQUIRED.

SAW BORE & DRIVING PEG CENTRES.

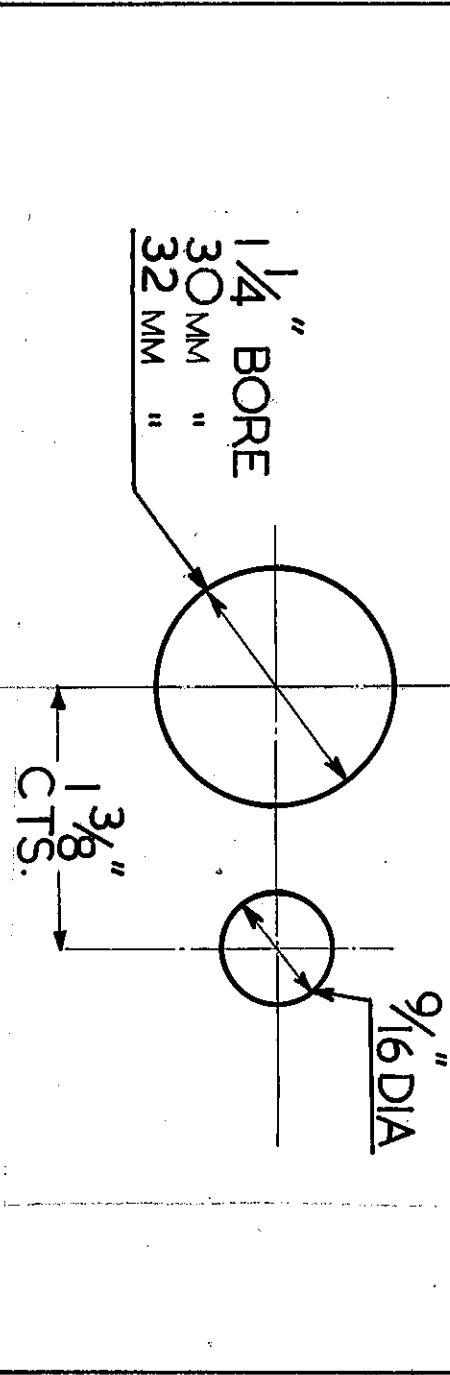

STOCK SAWS AVAILABLE TO ORDER

SAW DIA.	.SAW REF. 1 1/4" BORE	30 mm BORE	.32 mm BORE
305 mm (12")	BC 13	BC 13/M30	BC 13/M32
356 mm (14")	BC 14	BC 14/M30	BC 14/M32
406 mm (16")	BC 15	BC 15/M30	BC 15/M32
406 mm (16")	BC 130 *	BC 130/M30 *	BC 130/M32 *

* TUNGSTEN CARBIDE TIPPED.

MOUNTING SAWS

Isolate machine from air supply and mains power.

Raise saw guard into open position and lower saw compartment cover.

Check that the rear fixed saw flange is screwed onto the spindle tightly. (ON RIGHT HAND M/Cs FLANGE HAS RIGHT HAND THREAD, ON LEFT HAND

M/Cs LEFT HAND THREAD)

Clean faces of both front and rear saw flanges, and ensure driving peg is firm.

Mount saw on to spindle and locate on driving peg ensuring that teeth of saw blade run in correct direction.

Replace front saw flange hard up to saw and firmly lock in place with saw spindle nut.

Check that saw runs true by rotating spindle.

WOOD SAW PACKINGS

In the case of a new machine or one with new saw packings fitted, it will be required to cut through these inserts. This operation should be undertaken with the greatest of care and it is therefore recommended that the following sequence be followed.

1. Ensure machine is still isolated from both mains and air supply.
2. After following the previous section on 'mounting saws' or fitting new wood packings it is assumed that the guard is in the open position.
3. Adjust the saw guard sliding covers into such a position that they enclose the saw aperture completely, and raise the lower saw compartment cover into its top position.
4. Re-connect machine to electrical supply.
5. Swing saw guard over to within 20 - 30 mm from periphery of saw blade and hold in this position with plastic ball handle on the saw guard front. Start saw, and slowly lower guard down onto rotating blade until fully down in closed position, at which point the whole guard should be secured by means of the screw fastener.
6. Re-connect machine to air supply and complete the through cut of the saw packings by operating foot pedal. Repeat the saw stroke three or four times to give a good clean cut.

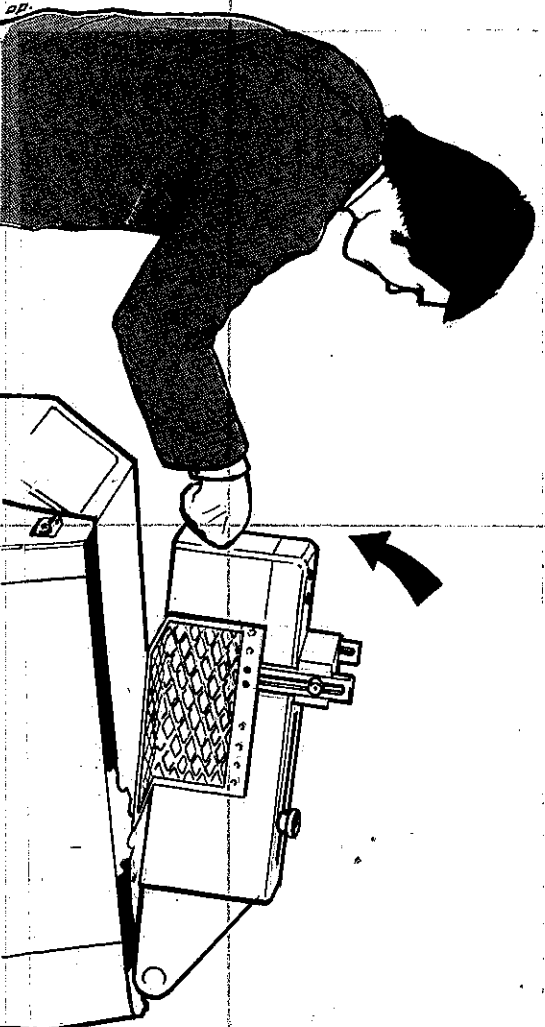
SAW PACKINGS (GENERAL HINTS)

It is usual to provide a saw blade with some form of packing, but it is not intended that this packing be used as a guide for buckled or out-of-true saws. The idea behind fitting such packings is to steady the saw, but it should be noted that the packing must not be tight as this will generate heat, resulting in a consequent loss of tension in the blade.

Always maintain wood inserts in good condition, and replace them before they deteriorate too far.

On despatch from the factory your machine has been fitted with inserts manufactured from high quality beech, we recommend that this material be used for future replacements.

Lengths of wood packing material can be supplied to your request.

SAW GUARDS

The guards provided should never be removed from the machine when operating, as they are placed there for your protection. They should always be adjusted in such a manner that there is minimum clearance between guard edge and outer faces of the workpiece (ie)

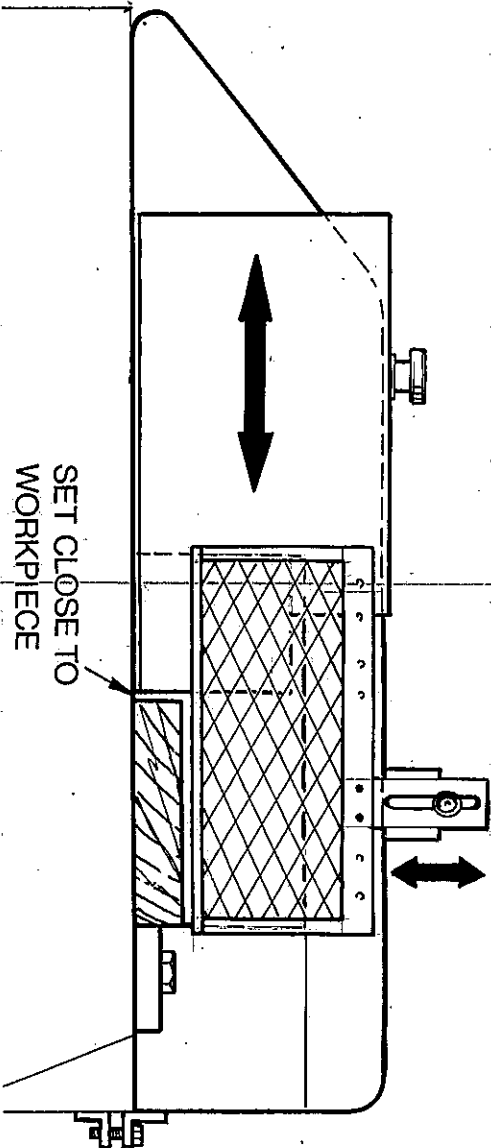

Similarly, the lower saw compartment guard should not be opened until both air and electrical supply have been isolated.

AIR EQUIPMENT IDENTIFICATION

The main air control equipment is situated beneath the flat plate cover on the machine base top and consists of the items shown in the view below (ie)

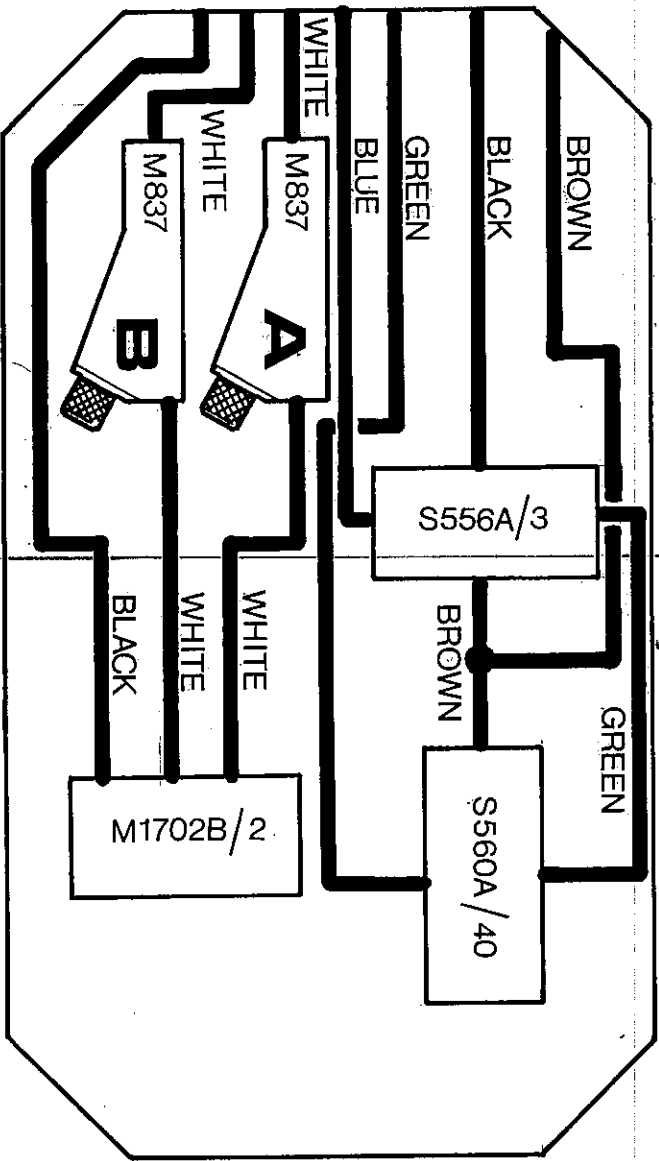

AIR EQUIPMENT OPERATION

Valves S556A/3 and M1702B/2 control cylinder via the foot pedal, whilst which only allows the main cylinder pedal is kept fully depressed. These should not be tampered with.

Units marked M837 are restrictor saw cylinder speed of stroke. These the knurled screws. Valve A controls whilst B controls the return action, inwards to slow down the action, If adjusting the restrictors, S837 hard against the top bump stop, or means of these valves the saw does attention should be given to the S560C/8 situated inside the machine

base. the air supply to the main saw valve S560A/40 is the safety valve to stroke once even if the foot valve require no adjustment and

and as such control the main units can be adjusted by means of the speed of the forward stroke, To adjust, screw knurled screws upwards to speed up the action. cause the saw carriage to 'bang' up upon slowing down the stroke by not cut through the timber, attention of the roller valves

NOTE:- Density of timber must be allowed for as the stroke will slow down when cutting, due to material resistance. It should also be noted that the saw carriage tends to 'bang-up' on the first stroke, especially when the machine has been at rest for some time or when the stroke is operated without a 'cut'.

ROLLER VALVES (S560C/8)

The roller valves are effectively pneumatic limit switches which sense the movement of the saw carriage in both top and bottom positions. The positioning of the front roller valve should be such that the saw can make a complete 'through-cut' of the timber without banging up on the top bump stop, then trip the roller to transfer to the saw cylinder to return the saw carriage, where the back roller valve should be set in such a position to sense this return and re-set to prepare for the next forward stroke, again without allowing the carriage to 'bang-down'.

General adjustment of the front roller valve is:-
towards the front of the machine to increase stroke distance set inwards to decrease distance, whilst on the back roller valve, adjusting towards the front of the machine will shorten the return stroke distance and adjusting inwards will increase return stroke distance.

Further to the above the length of stroke can be adjusted by moving the saw carriage main cylinder bodily by means of an adjustable mounting block. This block being situated inside the base is connected to an adjusting screw. To operate this feature unlock the 5/8 whit locknut (A) then with the aid of a spanner turn the square ended screw (B) in the direction desired to move the pivot along its mounting slot. After adjusting, re-lock locknut to secure in position. If it is found that the above adjustment should be made, for example for cutting smaller sections of timber, it may be necessary also to re-adjust the roller valve positions as outlined above, this however, would be determined by operation.

ROLLER VALVE CLEARANCE SETTING

It is important that the cam roller arms on the above valves have sufficient working clearance, as having them adjusted too close to their actuation point will cause damage. It is recommended that the valves be adjusted to give a clearance, as indicated on p8, thus ensuring that the arm will not be depressed hard down against the valve body.

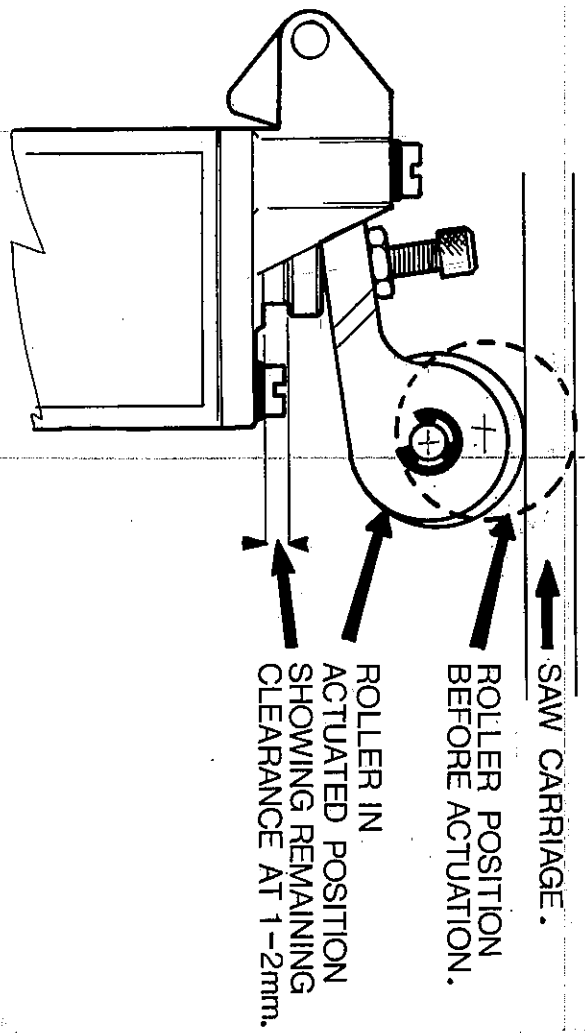
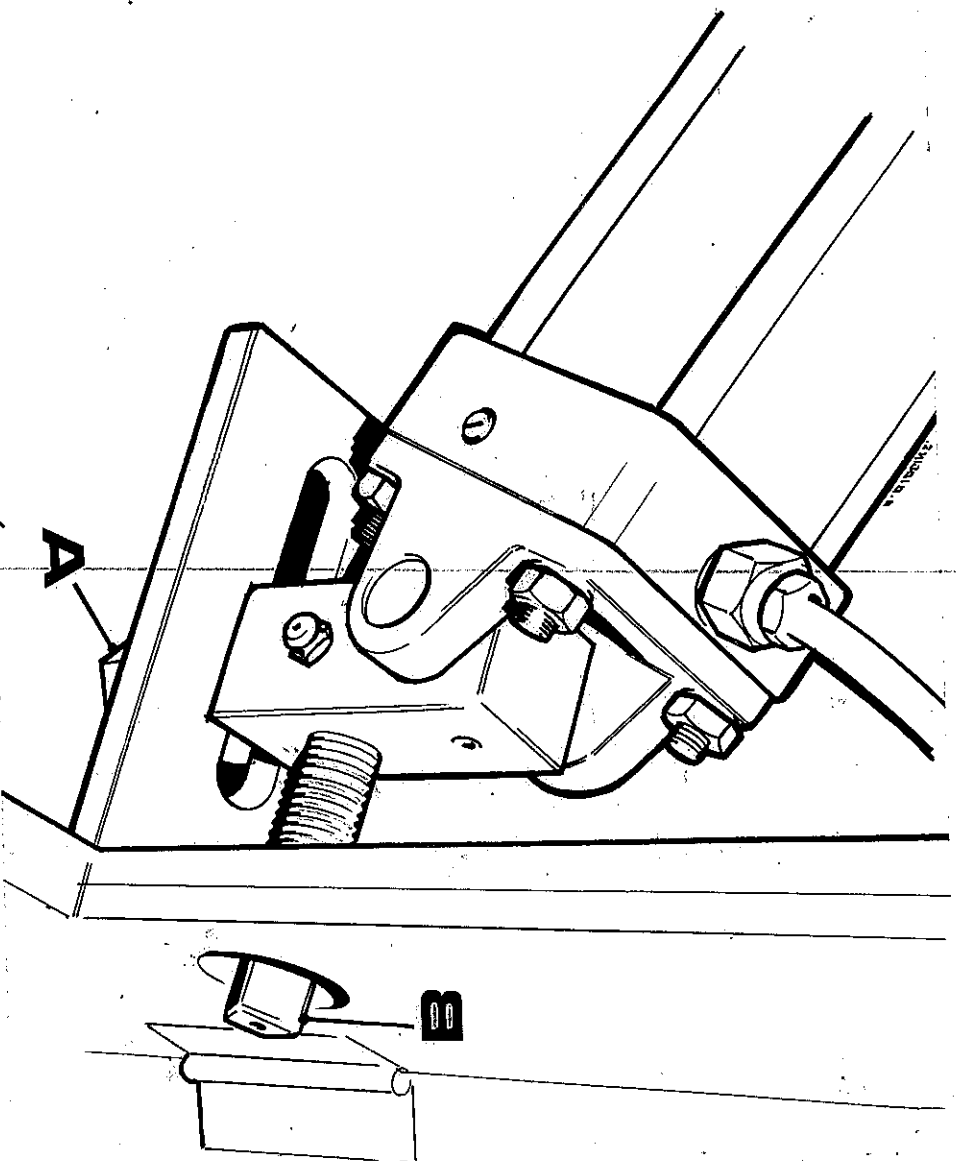

AIR FILTER

The air filter is an important integral part of the pneumatics system and its care and attention should not be abused. We recommend that this unit be inspected and drained regularly following the procedures given below.

DESCRIPTION:-

This filter is fitted with a 25 MICRON NYLON FILTER, should the element become clogged, the air pressure acting on the solenoid end will compress the spring causing the nylon filter to concertina and to throw off the majority of particles adhering to the surface, thus clearing itself. When the spring is compressed the red indicator band on the filter will clearly show above the black band on the perspex bowl. When the red indicator band appears permanently it is necessary to either change or clean the filter element.

SERVICING:-

1. Depressurise the unit and drain any sediment from bowl by opening tap B.
2. Isolate main air supply, release adaptor A and remove bottom cover C and barrel D along with the two 'O' Ring E.
3. Remove filter element G by rotating in a clockwise direction (bayonet fitting).
4. Clean filter element **USE ONLY DOMESTIC DETERGENT.**
5. Before reassembling ensure all internal parts are clean. The barrel may be cleaned with domestic detergent or paraffin **DO NOT USE DEGREASING FLUIDS OR CARBON TETRACHLORIDE.**
6. Replace barrel and bottom cover using new 'O' Rings if required.
7. Tighten adaptor A and close drain tap B.

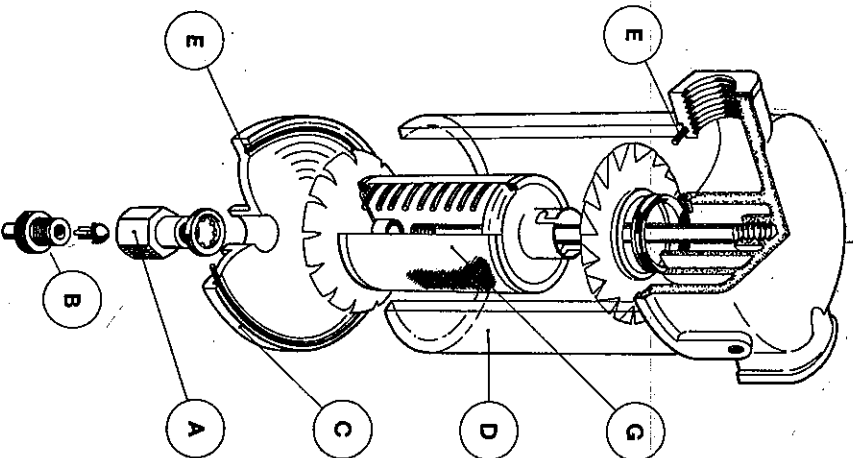

LUBRICATOR

It is important that the oil level be maintained at the point indicated on the lubricator barrel. We recommend and supply the machine pre lubricated with SHELL TELLUS 27, however, depending on availability the following equivalents may be used.

MAKE	AVERAGE AMBIENT TEMP. 40°F/5°C	AVERAGE AMBIENT TEMP. 70°F/21°C	AVERAGE AMBIENT TEMP. 100°F/38°C
SHELL	. TELLUS 21	. TELLUS 27	. TELLUS 33
MOBIL	. ARTIC OIL LIGHT	. DTE OIL LIGHT	. DTE OIL HEAVY MEDIUM
GULF	ESKIMO 35	HARMONY 44	HARMONY 53
REGENT	_____ 35	REGAL OIL A (R&O)	URSA P 20
CASTROL	HYSPIN 45	HYSPIN 70	HYSPIN 100
ESSO	. SPINESSO 36	. TERRESSO 43	. TERRESSO 52

NB:- If none of the above oils are available, any reputable hydraulic oil with a viscosity of 300 seconds Redwood at the appropriate ambient temperature is suitable.

DESCRIPTION

This lubricator is completely automatic and no adjustment is required. The action of the internal poppet valve ensures that a constant proportion of oil mist to air volume is delivered within the rated flow capacity of the lubricator.

SERVICING & INSPECTION

Because the main air stream does not pass through the bowl there is no tendency for water to condense, therefore, draining the oil by means of unscrewing drain tap M need only be carried out periodically. The 400 mesh filter J at the end of the pick-up tube will normally exclude any foreign matter likely to block jet C.

1. Isolate air supply and drain oil by unscrewing tap M.
2. Remove top cover A and gasket B.
3. Inspect poppet valve 'O'-Ring D and replace if worn.
4. Replace top cover A and gasket B.
5. Release adaptor L and remove bottom cover K and barrel H.
6. As it is impossible to ensure correct setting of the jet screw C without calibration equipment, we would suggest that this item is not removed from the unit but simply remove filter pick-up J and blow through pick-up tube to ensure jet is clean.
7. Clean filter element J with paraffin or weak detergent.
8. Ensure oil pick-up tube is clean and clear, then replace element J.
9. Clean barrel H and cover K with weak detergent.
10. Replace barrel and cover and tighten adaptor L.
11. Tighten drain tap M and refill to required level with clean oil.

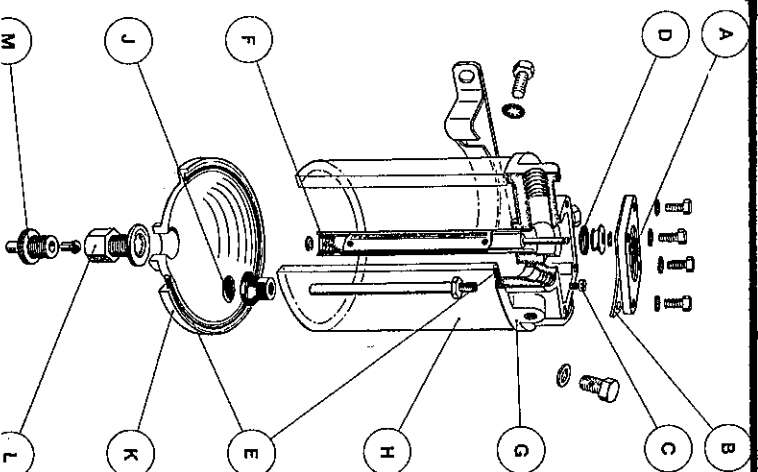

SAW SPINDLE BEARING REPLACEMENT

During the working life of the machine it may be required to replace the main spindle bearings. In such a case follow the procedure given below.

1. ISOLATE AIR AND ELECTRICAL SUPPLY.
2. RAISE SAW CARRIAGE INTO THE POSITION SHOWN BELOW AND BLOCK IN PLACE WITH A STOUT PIECE OF TIMBER AS INDICATED.

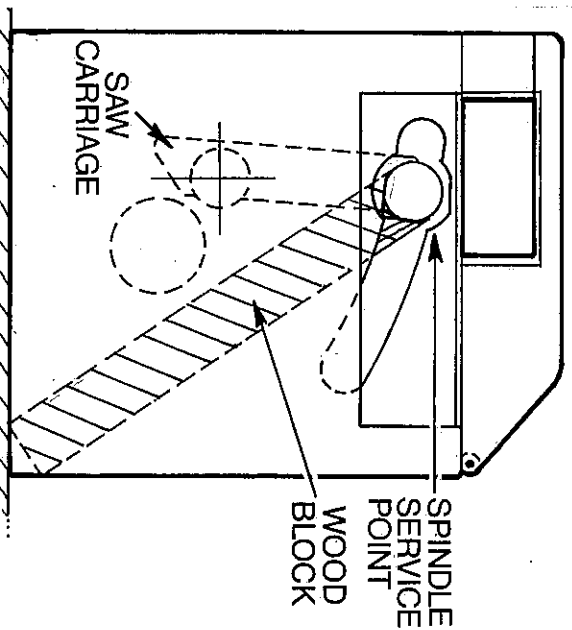

3. REMOVE SPINDLE NUT (A), LOOSE FLANGE (B) THEN WITH SUITABLY PROTECTED HANDS REMOVE SAW BLADE.
4. UNSCREW FIXED FLANGE (C) NOTE RIGHT HAND THREAD ON RIGHT HAND MACHINES, LEFT HAND ON LEFT HAND MACHINES.
5. UNSCREW THE ENDCAP RETAINER SCREW (D) THEN REMOVE ENDCAP (E).
6. SLACKEN BELT TENSION AND REMOVE DRIVE BELTS (F) (SEE BELT TENSION SECTION).
7. REMOVE PULLEY END BASE COVER AND UNSCREW PULLEY RETAINING SCREW AND WASHER (G).

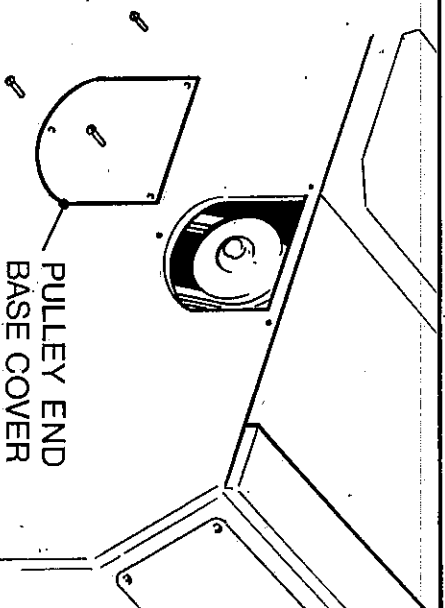

8. UNLOCK GRUB SCREWS (H) AND WITHDRAW PULLEY (I) AND KEY (J) FROM SHAFT.
9. REMOVE COLLAR (K) AND ENDCAP (L).
10. WITH A WOODEN DRIFT DRIVE THE SPINDLE, FROM THE PULLEY END, THROUGH THE HOUSING UNTIL THE SAW END BEARING EMERGES. REMOVE SPINDLE AND TAP BALL RACE OFF.
11. RE-INSERT SPINDLE AND DRIVE THROUGH TO REMOVE REMAINING BEARING. (USE WOOD DRIFT)
12. THOROUGHLY DE-GREASE ALL PARTS AND CHECK THEIR CONDITION.
13. TO REPLACE, REVERSE ABOVE PROCEDURE, BEFORE RUNNING THE FOLLOWING POINTS SHOULD BE CHECKED: - BEARINGS RE-GREASED. ALL SCREWS, KEYS AND COLLARS ARE SECURE. BELTS TENSIONED PROPERLY. SAW FLANGE SCREWED ON TIGHT AND BLADE SECURE.

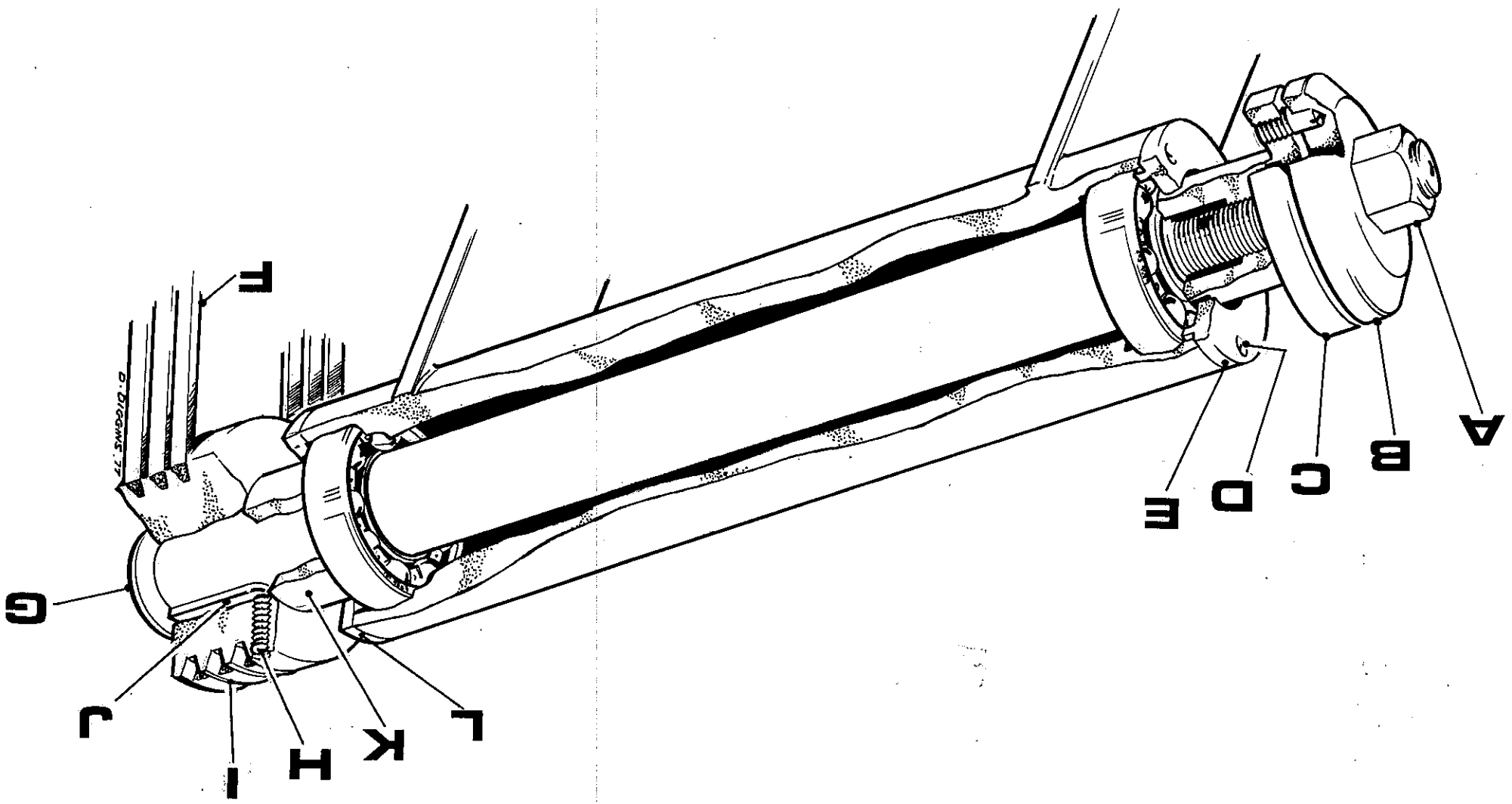

BELT TENSION & REMOVAL

To remove drive belts from pulleys simply unlock and screw up the two top nuts A on the motor tension plate. Screw up two lower nuts B thereby raising the motor and relieving tension on the belts enabling them to be removed from the pulleys.

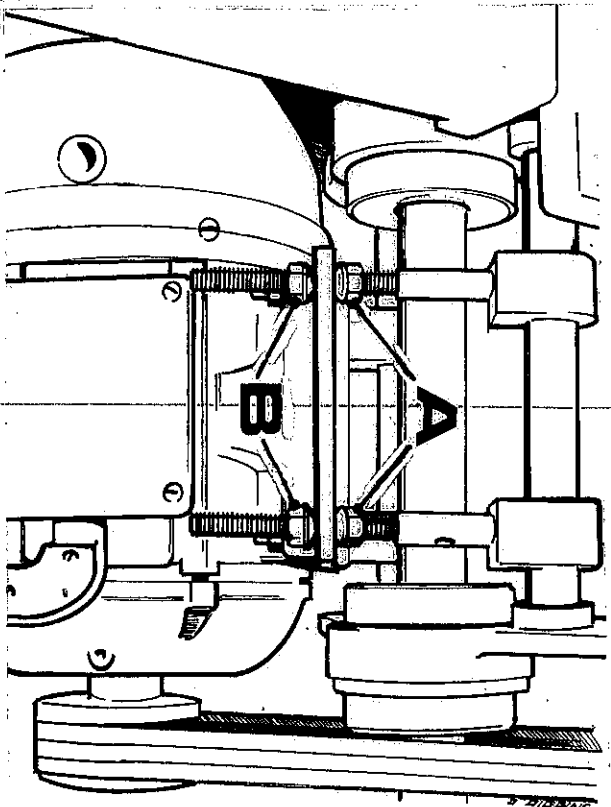

To replace and retension belts, place belts over saw spindle pulley then screw down nuts B lowering motor pulley onto belts, ensure that belts locate in their respective grooves. At the point where the belts support the motor and locknuts B can be screwed down further without allowing the motor to drop, screw down nuts A and lock nuts A and B against one another to retain this position. After a short running-in period it is recommended that the belt tension is checked and adjusted accordingly. A guide to the correct amount of tension is given below. (ie) Whilst applying a force at right angles and central along the belt, the deflection should not be greater than 16 mm per metre of span (eg) ON THE BCW MACHINE DEFLECTION SHOULD BE APPROXIMATELY 8 - 10 mm.

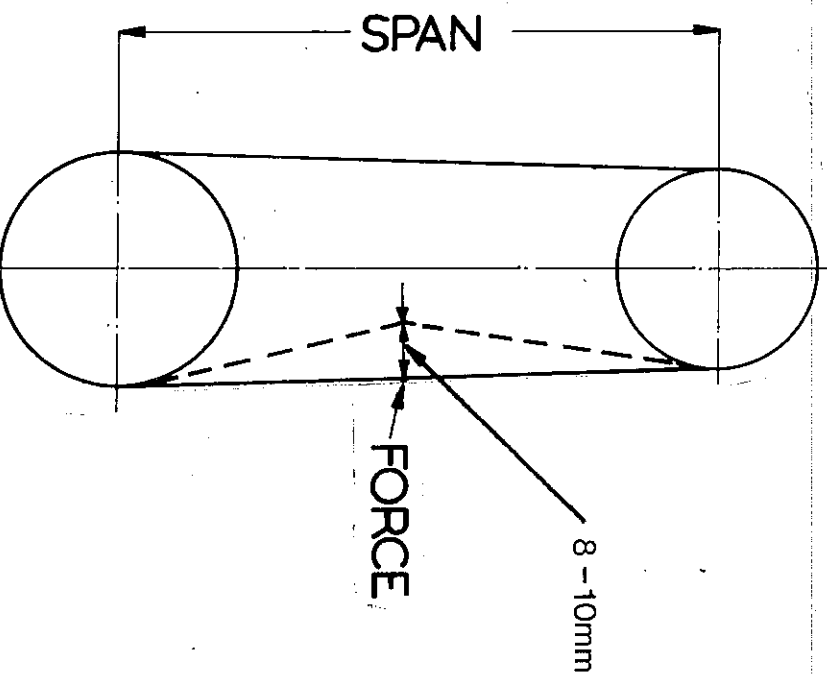

OPERATION NOTES

THE FENCE. The fence is normally set square from the saw upon despatch but by slackening the two fixing bolts it can be adjusted to suit requirements.

To ensure square cutting always make sure that timber is kept up to the fence.

THE FOOT PEDAL

By depressing the foot pedal the saw carriage will swing forward and make a cutting stroke. When the cut is completed release the pedal as the saw carriage retracts, after which depressing pedal again will actuate the cutting stroke. It should be noted that keeping the foot pedal depressed will cause the safety valve to cut in, which will not allow the system to re-set for a further cutting stroke until the pedal is released.

CUTTING. Although high cutting stroke speeds are capable by this machine, it should be noted that in some cases where a good finish is required 'on cut' the stroke should be slowed down until the desired results are obtained. The method of controlling the saw stroke is covered in the (air system section).

IMPORTANT

NEVER OPERATE MACHINE WITHOUT GUARDS IN PLACE.

ALWAYS ADJUST GUARDS AS NEAR AS POSSIBLE TO TIMBER SECTION BEING CUT. KEEP HANDS WELL CLEAR OF SAW AREA.

NEVER ATTEMPT TO APPROACH THE SAW BLADE UNTIL THE SAW HAS STOPPED AND HAS BEEN ISOLATED FROM BOTH PNEUMATIC AND ELECTRICAL SUPPLY.

IF MACHINE IS NOT COUPLED TO A NORMAL EXTRACTION SYSTEM NEVER PUT HANDS INTO THE SAW CHUTE AREA EITHER VIA THE TOP ACCESS OR UP DUST OUTLET. DO NOT OPEN SAW GUARDS UNTIL SAW HAS COME TO REST. NEVER RUN SAWS LESS THAN 10" (250 mm) IN DIA.

SAW DUST OUTLET SAFETY STRIPPS

The strip of metal welded across the mouth of the chip chute is placed there for your safety and should only be removed when the machine is connected to a dust extraction system.

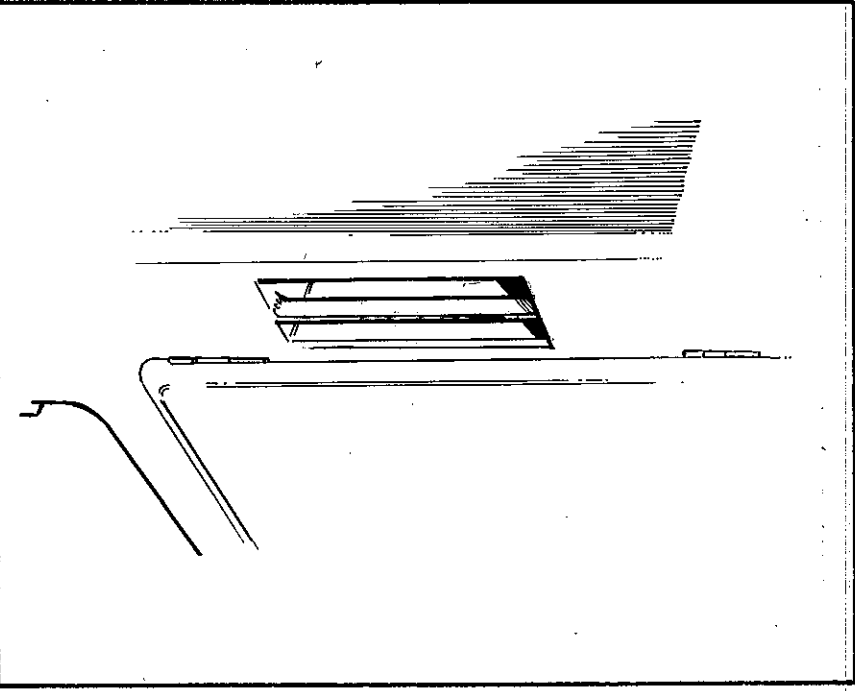

LUBRICATION

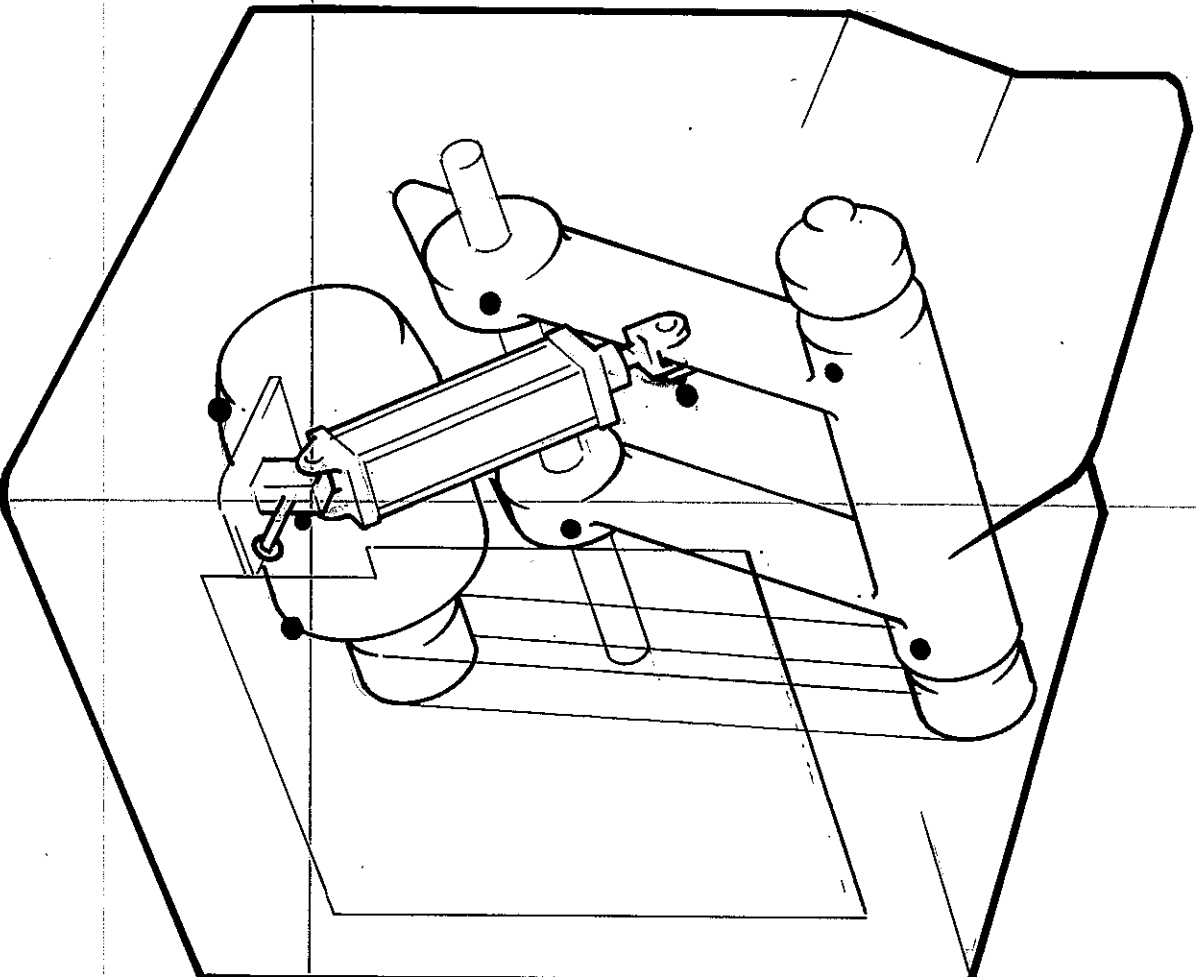

Grease points **Grade L6**

WADKIN OILS & GREASES WITH RECOMMENDED ALTERNATIVES

Wadkin Grade	Castrol Equivalent	Mobil Oil Co. Equivalent	Shell Equivalent	Regent/ Caltex/ Texaco
L. 2	Alpha 417	Mobil Dte Oil BB	Vitrea Oil 69	Meropa 2
L. 4	Perfecto NN	Mobil Vactra Oil Heavy Medium	Vitrea Oil 33	Ursa P. 20
L. 6	Spheerol AP3	Mobilux Grease No. 3.	Alvania Grease No. 3.	Regal/ Starfak Premium 3

It is recommended that all greasing points shown above should be given one or two shots of grease every month.
 On machines fitted with 7.5 HP motors the bearings are sealed for life and should require no further attention.

**STOP BAR &
AIR OPERATED
STOPS**

STOP BAR & AIR OPERATED STOPS

Further to the basic machine graduated stop bars and air operated stops can be fitted. The basic addition being a 4'- 2" (1,250 mm) long bar with one stop and support leg, knee bracket and pipe plate.

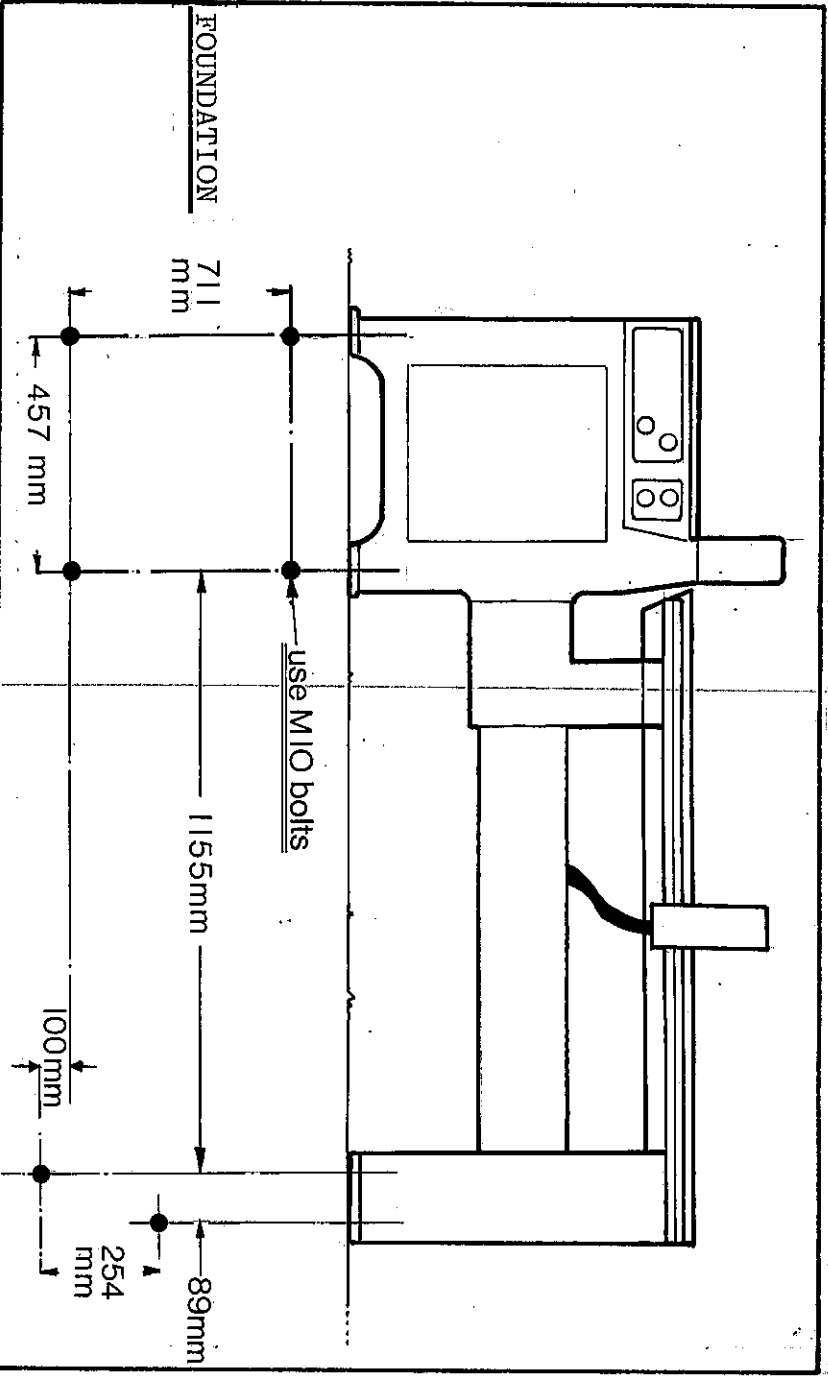
ASSEMBLY

In some cases the stop bar and pipe plate (etc) will be supplied, for transportation reasons, in a sub-assembly form and should therefore be assembled as shown below.

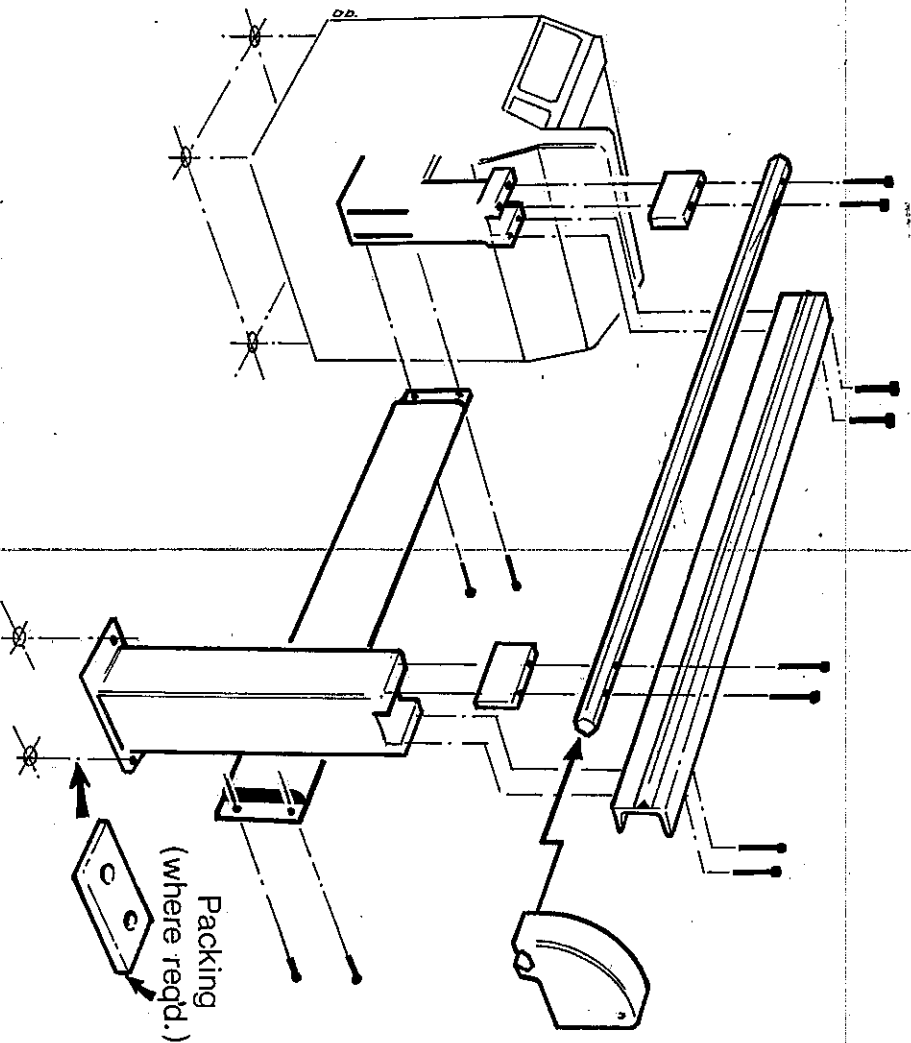

ASSEMBLY CONTINUED

Packing may be required beneath the outer support leg to bring the stop bar and channel level to the machine top table. The bar should also be checked for being parallel to the machine fence and the level of the whole set-up should be checked by a spirit gauge before final bolting down.

AIR CONNECTION

Remove cover from the pipe plate and connect the air lines to the brass manifold block. These connections will be tagged and should be connected correspondingly or by following the colour code (ie).

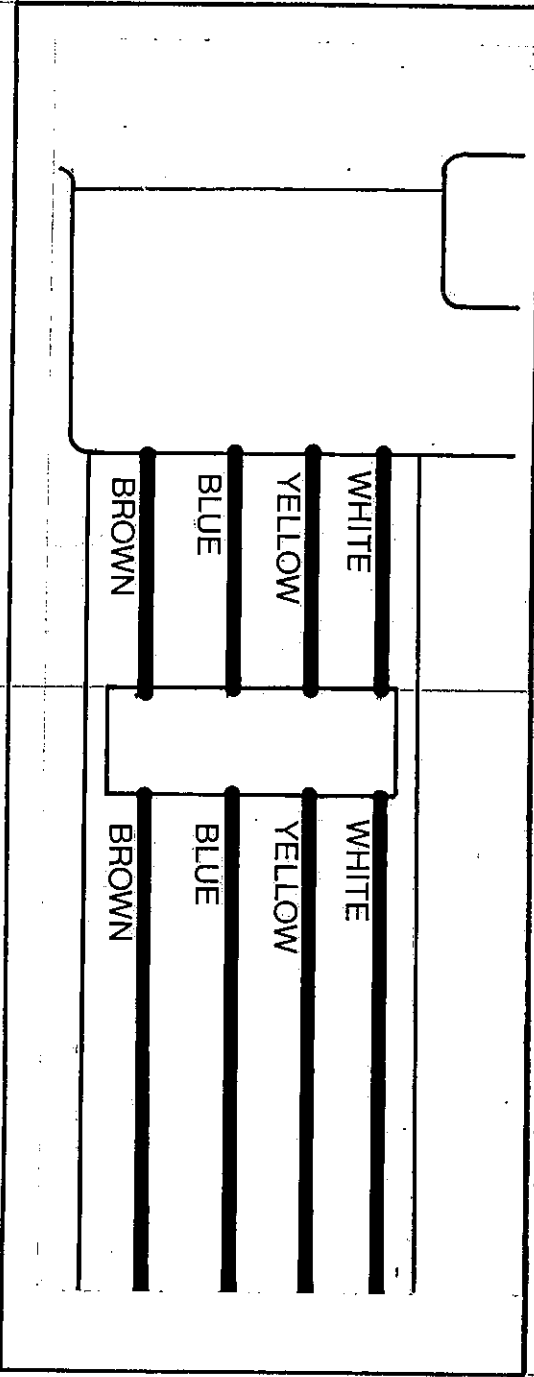

STOP INSTALLATION & AIR CONNECTION

The stop should be fitted onto the hexagonal bar as shown and checked for a good slide fit and positive locking. The air line connections should now be secured by connecting the main pipe plate lines to the corresponding symbol or colour codes on the stop valve (ie).

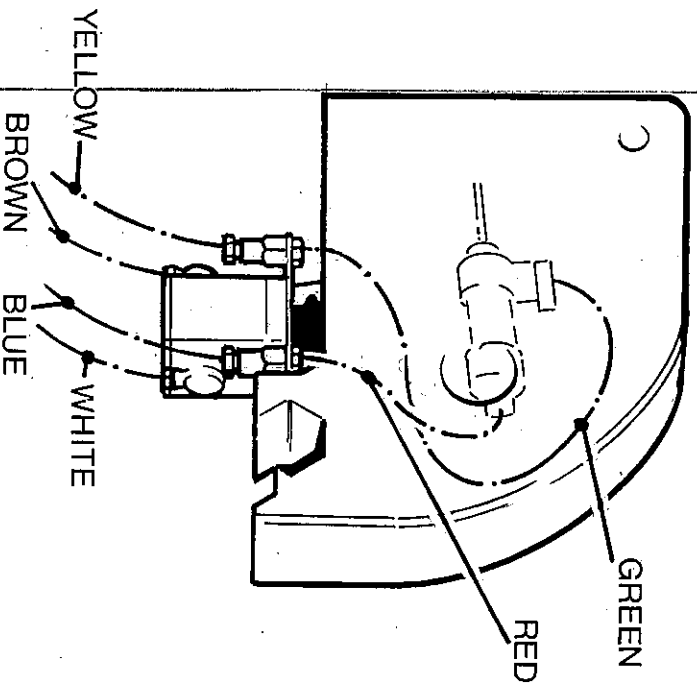
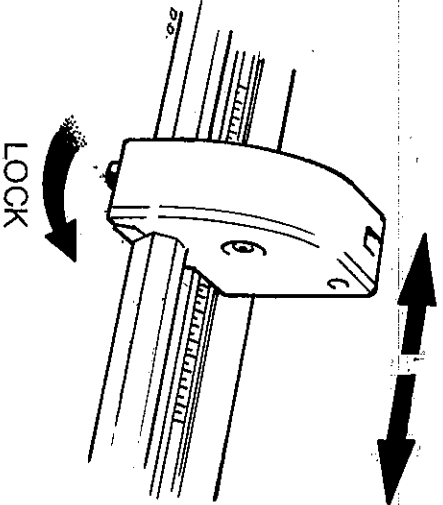

AIR OPERATED STOPS

The stop is an important unit of the machine and as such several points should be noted.
INTERNAL AIR EQUIPMENT & ARRANGEMENT

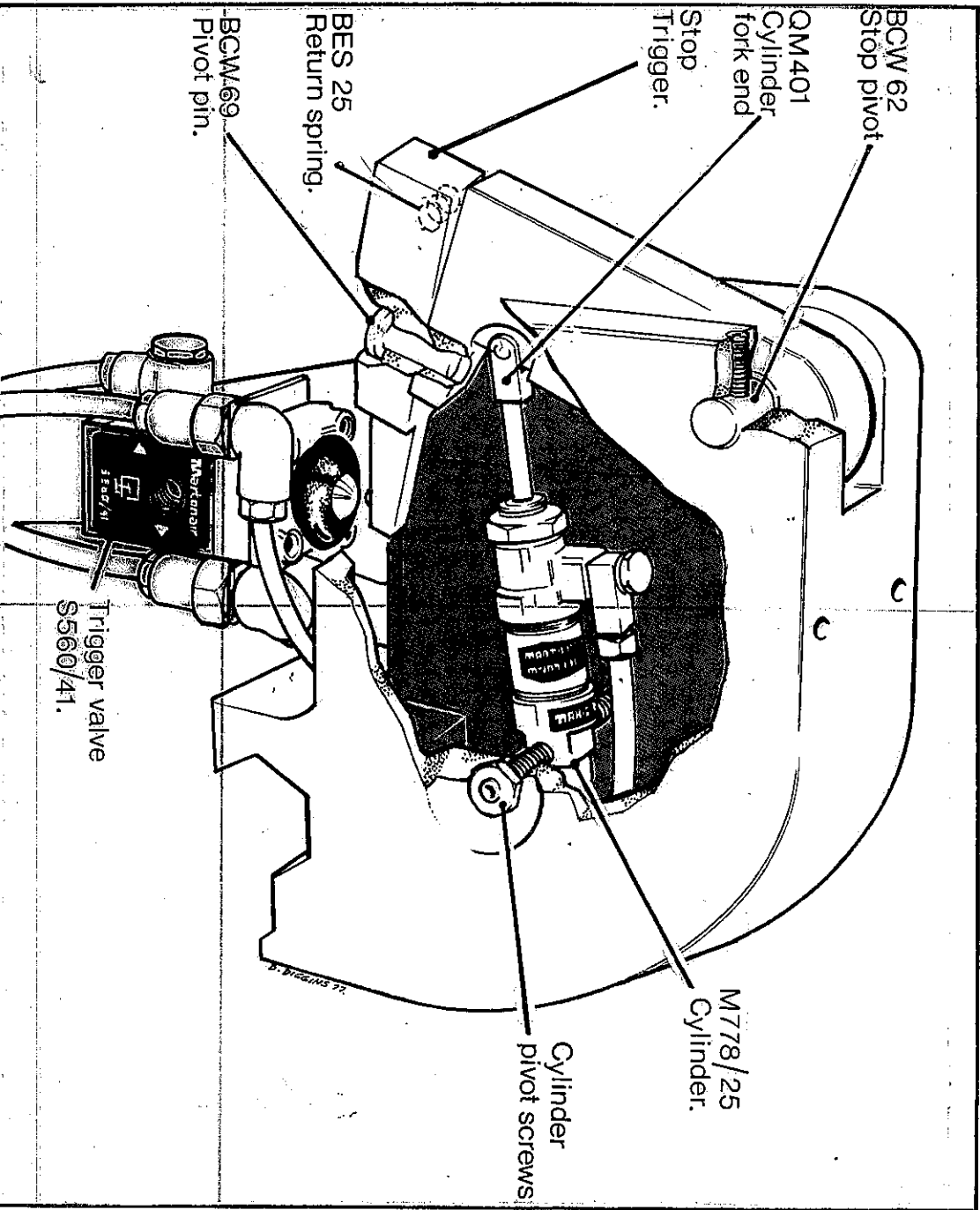

AIR TRIGGER VALVE S/560B/41

This valve is mounted beneath the stop body and gives the saw stroke signal when the trigger is actuated. It is important that this valve is set correctly in relation to the trigger (ie) when the trigger is out and the trigger finger pressed forward the small brass rivet should make contact with the domed valve cap and depress it to actuate the signal. The amount by which the domed cap is depressed is important and should be adjusted so that when the trigger finger has made contact there is still some 1 - 2 mm of downwards travel before becoming solid. Having the valve adjusted without any clearance can cause damage, therefore, if adjustment is required simply unlock the fixing screws on the valve mounting bracket and set to give position indicated below.

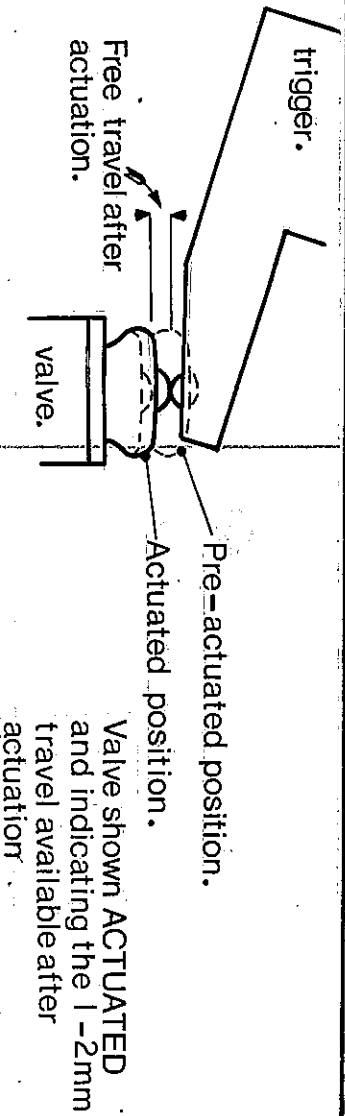

STOP POSITION SETTING

Each stop is fitted with a datum pointer which gives a direct visual reading from the rule on the stop channel. The rule is calibrated in both metric and imperial units and is positioned to give readings directly from the line of the sawblade.

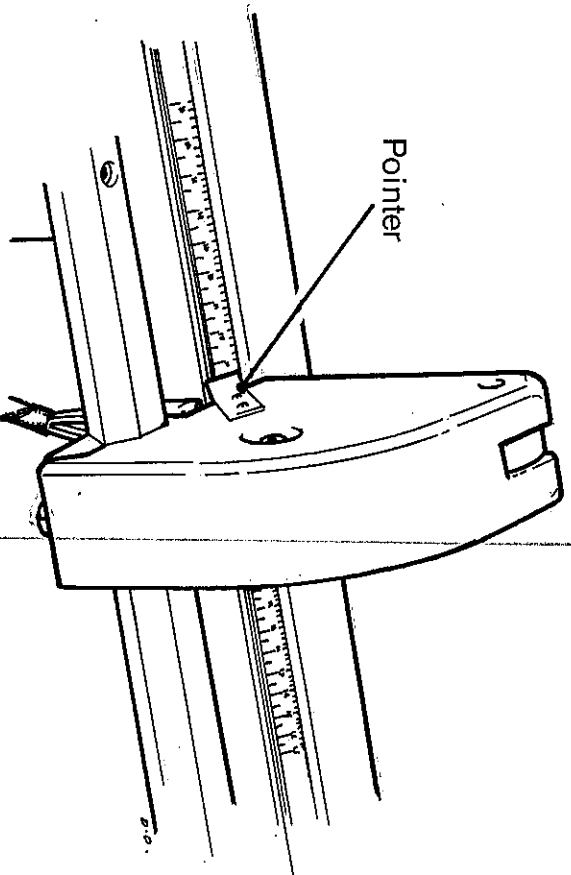

AIR OPERATED STOPS LUBRICATION & MAINTENANCE

The following points should be checked at normal service intervals.

- (1) Blow out inside of stop body to clear any dust and chips etc.
- (2) Check correct adjustment of trigger valve (see page 18)
- (3) Check action of spring loaded trigger.
- (4) Check that the stop air cylinder (M778/25) pivot screws are adjusted correctly and that the cylinder is not loose. (see below)
- (5) Lubricate stop trigger main pivot and all other moving components with Wadkin grade L2 oil (see page 15)
- (6) Check all air connections are tight.

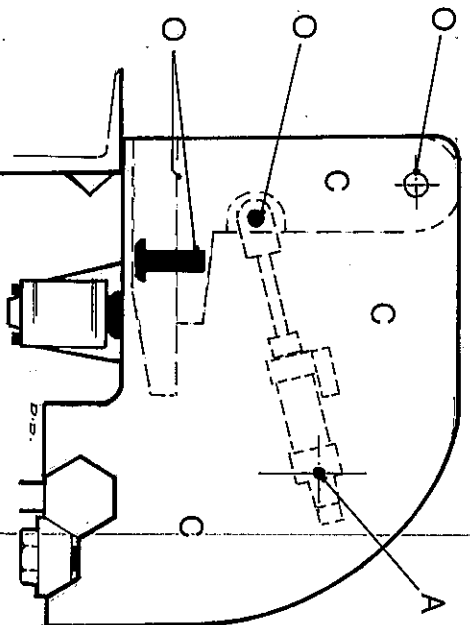

ACTUATOR CYLINDER (M778/1) PIVOT ADJUSTMENT

The trigger actuator cylinder has two adjustable pivots one either side of the stop body. These pivots should be adjusted in such a manner that they guide the cylinder but do not lock it in place.

AIR SYSTEM

The main air controls are situated beneath the main base top cover and are identical to those previously described on page 6 with the addition of valve M1702C/3 which is fitted to all machines with one or more stops. The arrangement of this panel is illustrated below.

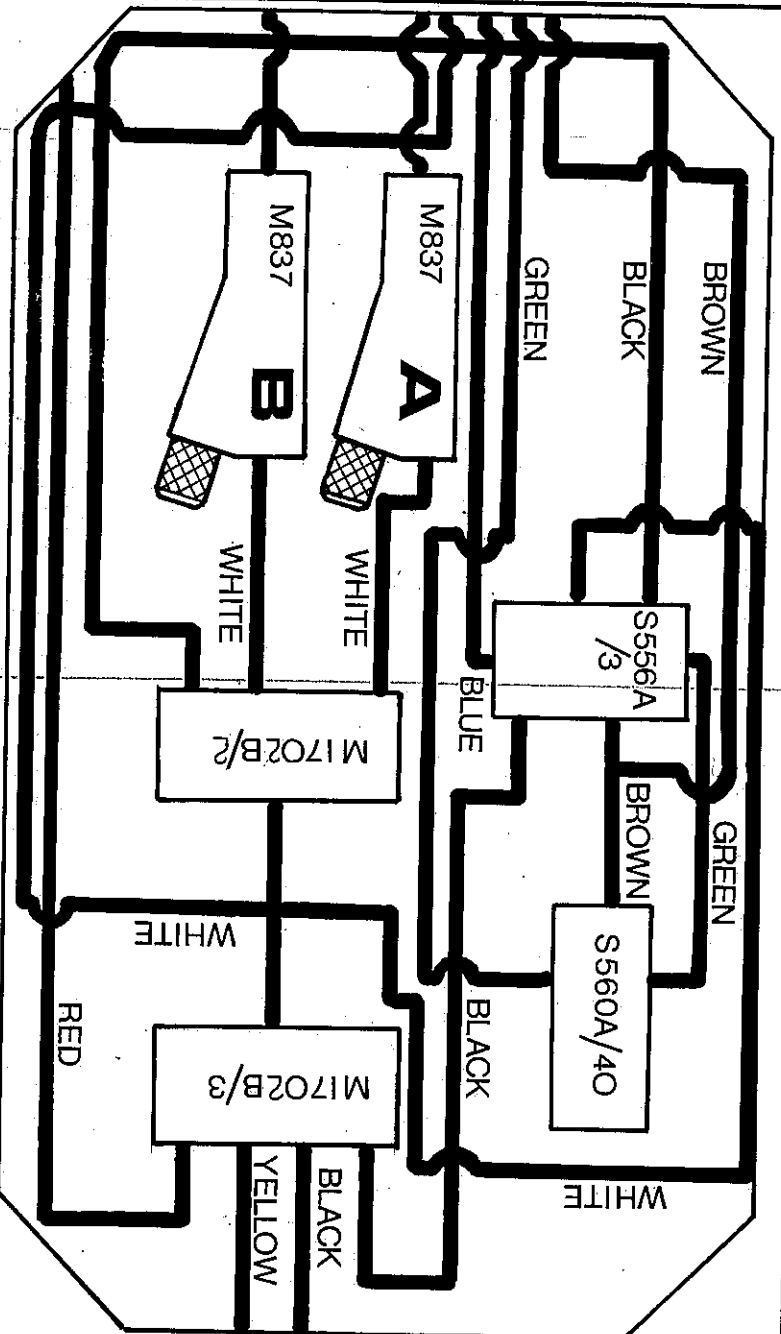

ROLLER VALVES (S560C/8)

Further to the two roller trip valves fitted on the basic machine (see P. 7 P 8) a third roller valve is incorporated on all machines with one or more stops. This valve is the foremost of the three, when viewed from the air pressure gauge side of the machine, and is set to cause the stop trigger to retract into the stop body as soon as the saw cut has been completed. (See pages 7 & 8 'Roller Clearance Setting'.)

STOP CONTROL PANEL

The basic stop control panel consists of two manual operated air push buttons which are arranged as shown.

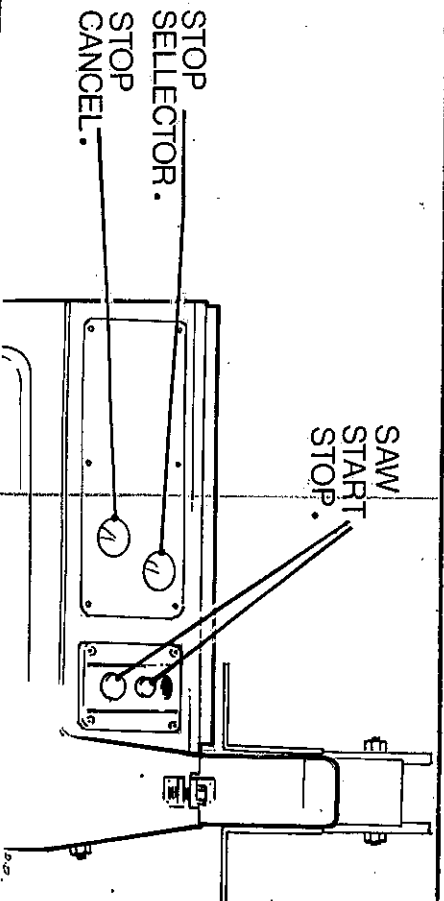

To select the stop depress the selection button which will send the stop trigger out. When selected the trigger will move in and out as directed by each cutting cycle and will only remain retracted within the stop body after the cancel button has been operated.

STOP CONTROL PANEL AIR EQUIPMENT

The diagram below illustrates the air equipment used and the arrangement of the single stop air panel (rear view).

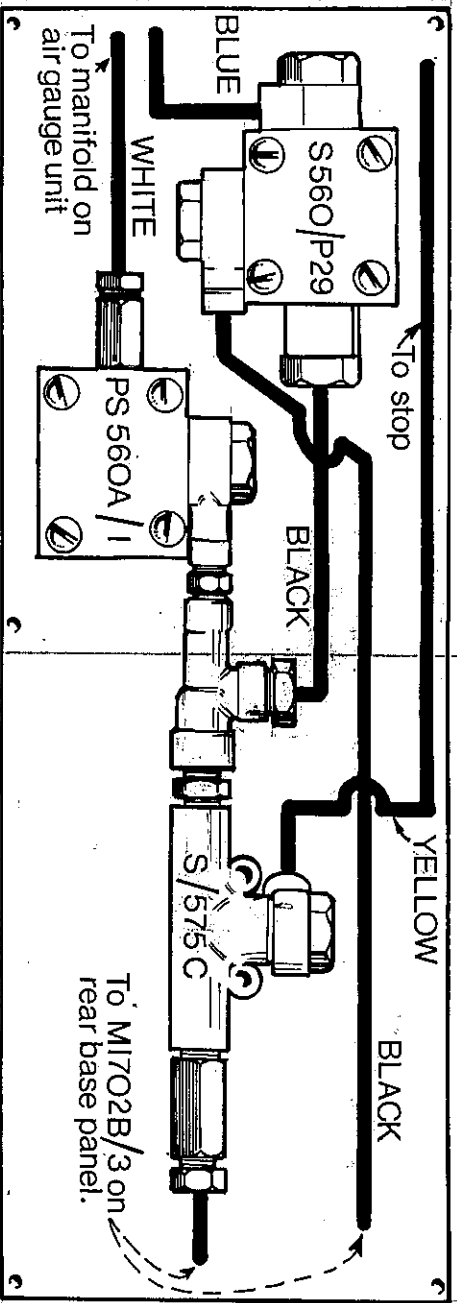

ADDITIONAL AIR OPERATED STOPS

Further to a single stop machine, additional stops can be supplied in any increment up to five maximum. In doing so the air system on the machine side is exactly as previously outlined with the exception of the control panel which has a corresponding number of selector buttons to the number of stops fitted, ie five stops, five buttons. An important point to note is the positioning of each button on the panel (eg).

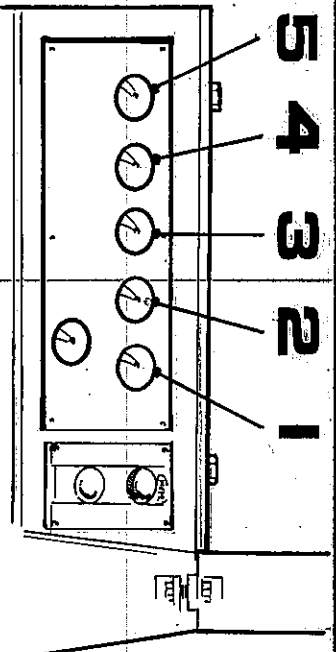

Arranging the buttons in this way directly identifies the stop on the stop bar by a corresponding position on the control panel.

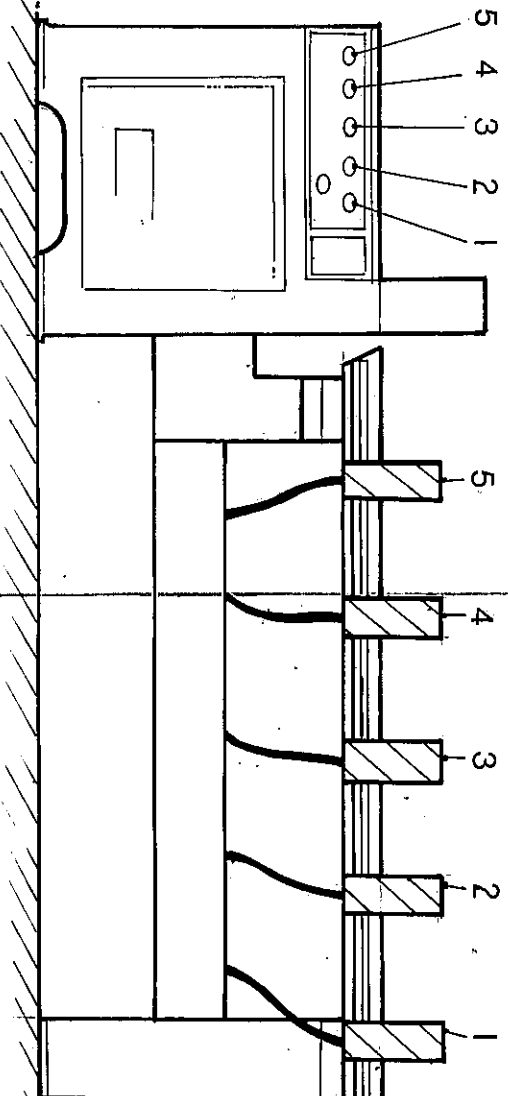

STOP CONTROL PANEL AIR EQUIPMENT (5 STOP MACHINE)

The following diagram illustrates the arrangement of air equipment on the control panel rear.

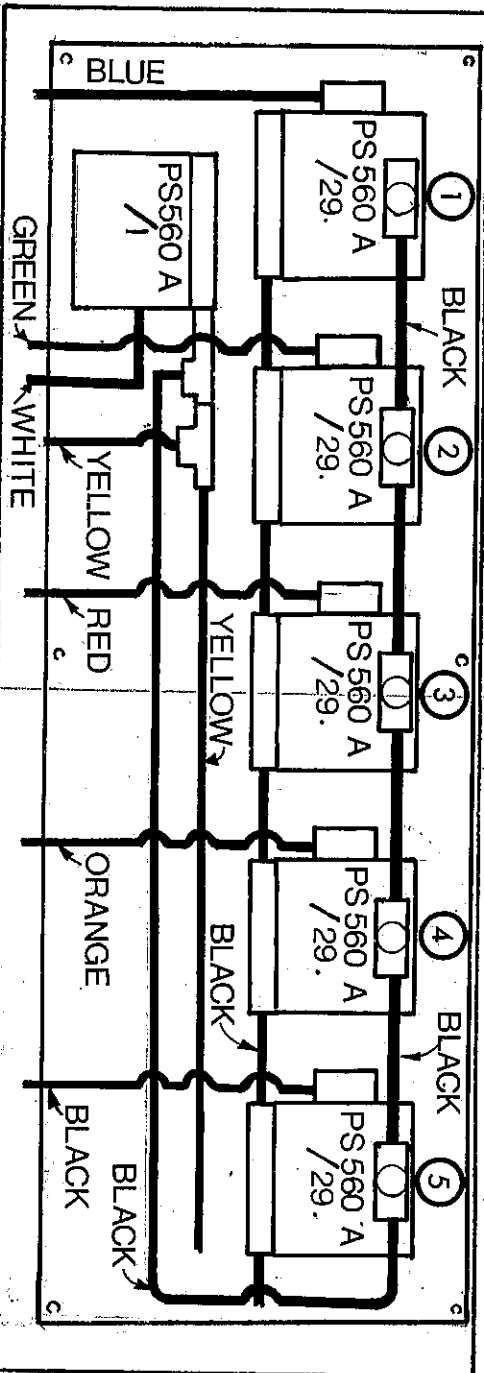

GRADUATED STOP BARS & CHANNELS

Further to the basic 1250 mm (4'2") long stop bar and channel, other lengths of bar can be fitted in order to increase the capacity of the machine. The other lengths in addition to the above are 2500 mm (8'4"), 3750 mm (12'6") and 5000 mm (16'10"). In order to provide these lengths, 1250 mm (4'2") and 2500 mm (8'4") lengths which provide the overall capacities indicated above (ie).

- 1250 mm (4' 2") Long M/C 1 Length 1250 mm Long.
- 2500 mm (8' 4") Long M/C 1 Length 2500 mm Long.
- 3750 mm (12' 6") Long M/C 1 Length 1250 mm plus 1 Length 2500 mm
- 5000 mm (16'10") Long M/C 2 Lengths 2500 mm (8'4").

Where overall lengths are a combination of two sections, supporting legs and connecting blocks are supplied. In most cases packing will be required under the support legs to bring the channel and bars level to the machine table, whilst lining up the bars to the machine fence is essential.

Approximate foundation centres for the sizes of stop bar are shown below.

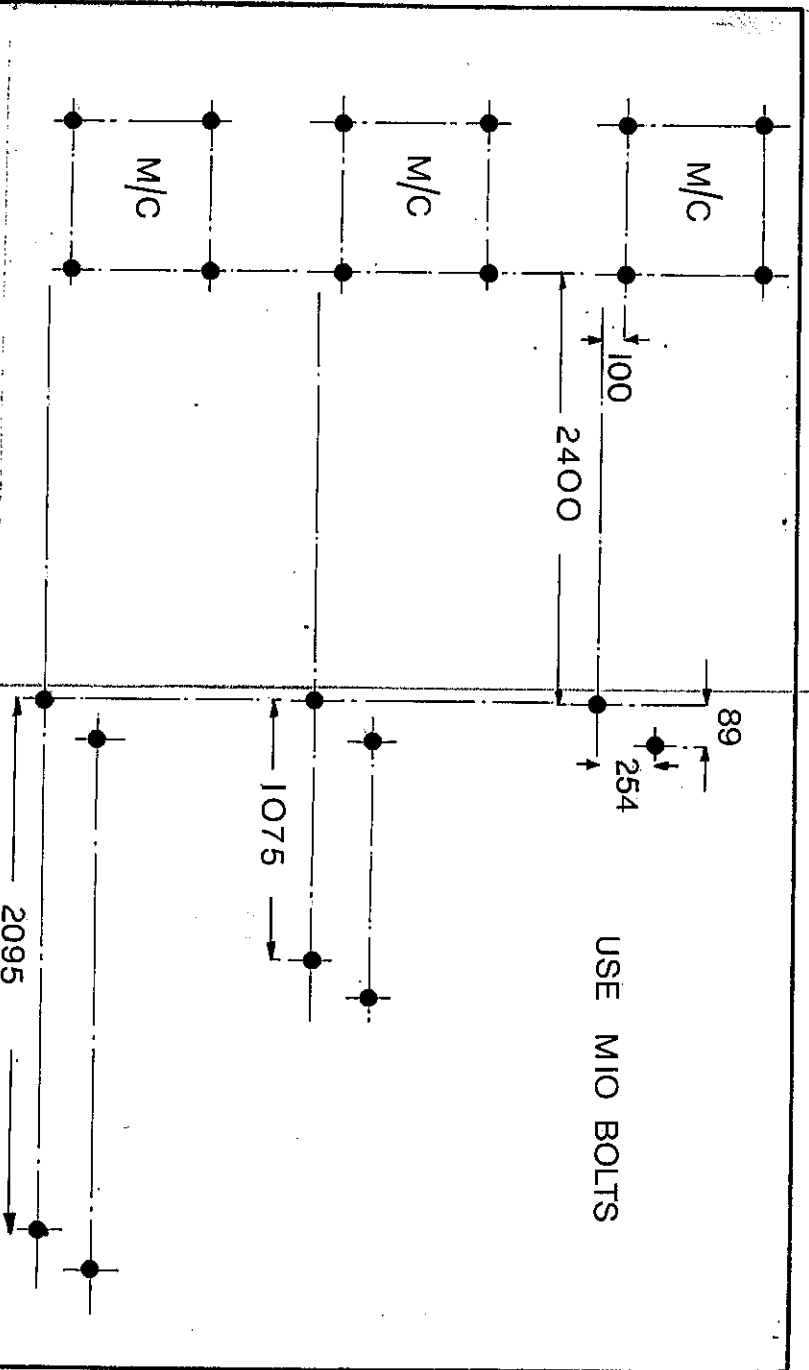

STOCK FALL AWAY PLATES

These plates are fitted to the stop to fall onto a belt or roller table operation.

They are available in lengths to suit the sizes of stop bars previously outlined.

If supplied separate to the machine for transportation the plate should be re-fitted to the channel as shown below with the screws provided.

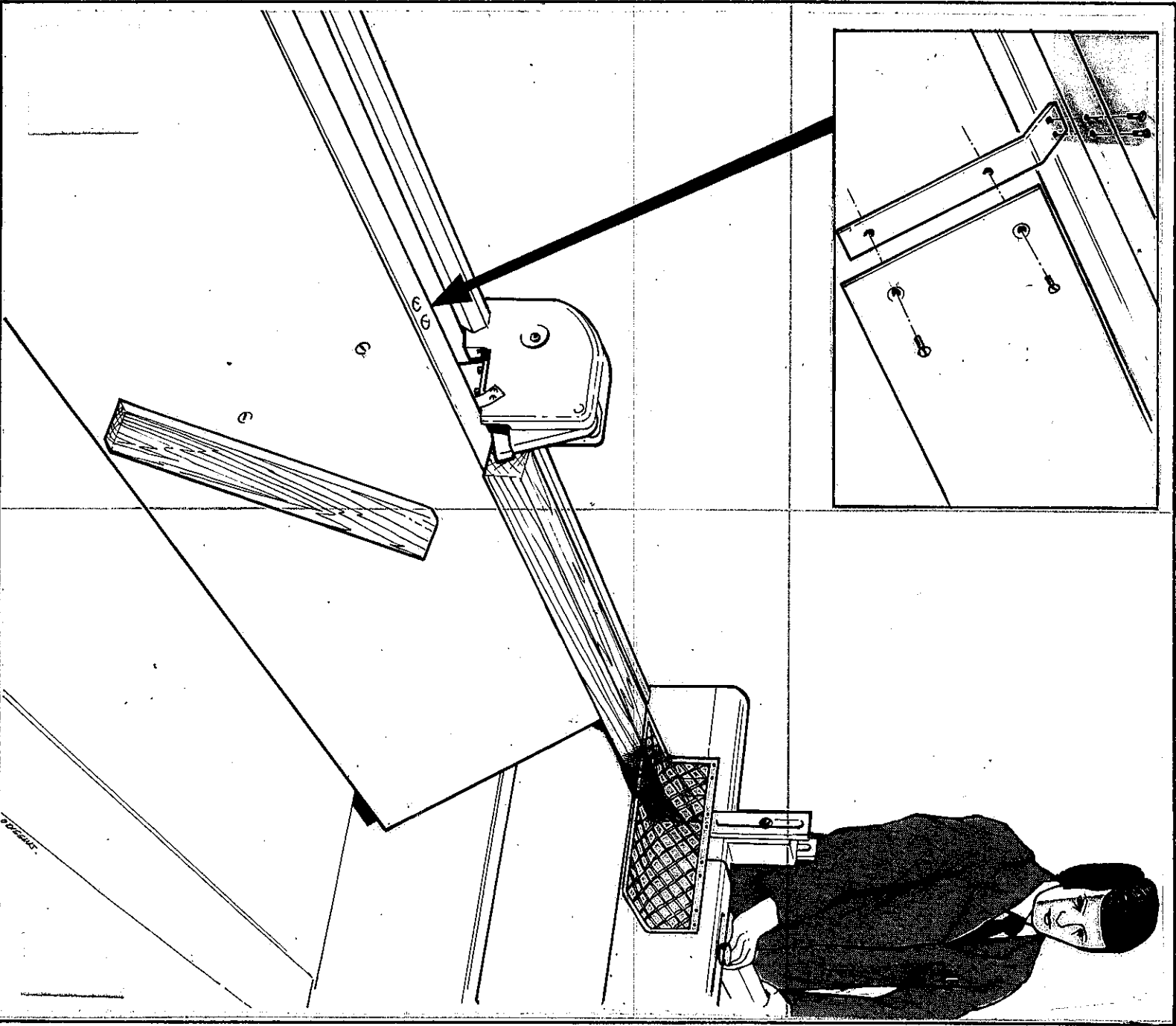
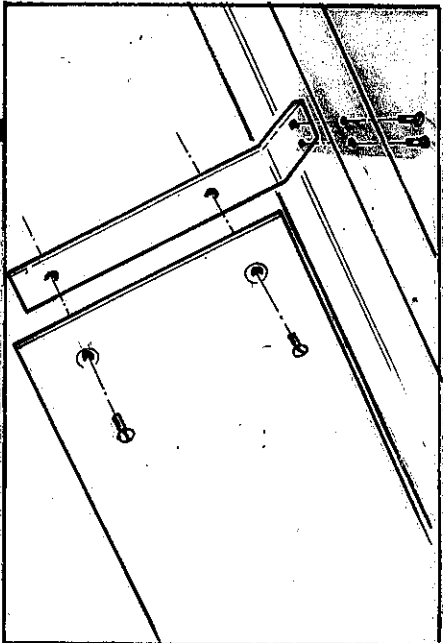

AIR SYSTEM SEQUENCE DESCRIPTION

The selection of a required stop is made by pushing in the appropriate button on the control panel (indicated stop No.1 - No.5). Manual cancellation to retract the stop is achieved by operating the push button (reset) mounted beneath the stop selection buttons. As drawn the circuit shows No.1 stop selected, the operational sequence is as follows.

On pushing the timber against the stop the valve within the stop (T1) is operated, the output signal passes through tee valve (R1), operates valve (M) and also passes through valve (X) to operate valve (Y) which powers the saw cylinder forward releasing valves (S) and (Q) before cutting the timber. On completion of this motion trip valve (P) is operated changing over valve (X), this causes two simultaneous actions:

- 1 :- This signal operating valve (Y) is exhausted allowing the saw cylinder to return.
- 2 :- A mains air signal from valve (X) changes over valve (Z) to retract any stops which are extended, in this case stop No.1. The signal operating valve (M) is exhausted.

As the saw cylinder travels back it trips valve (Q) which resets valve (Z) to put out any selected stop, and then trips valves (S) which reset valve (X) ready for the next signal from the stop trip valve (T1). Operation of foot pedal (F) will replace the signal received from the trip valve in the stop to power the saw cylinder. The pedal must be released to allow the signal operating valve (M) to exhaust between each stroke.

FAULTS

On the pneumatic side internal faults will occur if the air supply is not maintained in a clean dry state or the filter and lubricator units are not checked periodically and serviced as outlined.

The air pressure should be maintained at between 80 - 100 lbs/in² to ensure the best performance from the air system and valves (etc). Service and maintenance points should not be ignored and the machine should be regularly cleaned of all wood-dust, chips and off cuts.

FAULT FINDING

The following can be caused by loose connections, air pressure volume low, empty oil lubricator, air filter requiring attention, as these points tend to make cylinders and valves stick or become sluggish

SAW STROKE SLUGGISH
Valves M837 adjusted too finely.

SAW FAILS TO CUT THROUGH TIMBER
Valves M837 adjusted too low.

Saw too small in diameter.
Front roller valve S560 C/8 too far back.
Drive belts slack.

SAW FAILS TO COME FORWARD EVERYTIME
Trip valve S560 B/41 under stop requires adjusting.
Back roller valve S560 C/8 requires adjusting.

SAW FAILS TO RETURN
Front roller valve S560 C/8 set too far forward.
Foot pedal released too soon.

STOP FAILS TO KICK OUT
The back roller valve S560 C/8 under the saw compartment has failed to operate due to the saw return stroke being too short.

STOP FAILS TO CANCEL OR RETURN
Dust under the head of the stop panel cancel button.

Faulty stop cylinders.
Front roller valve S560 C/8 set too far out.

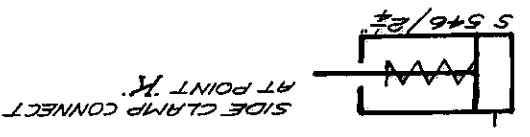
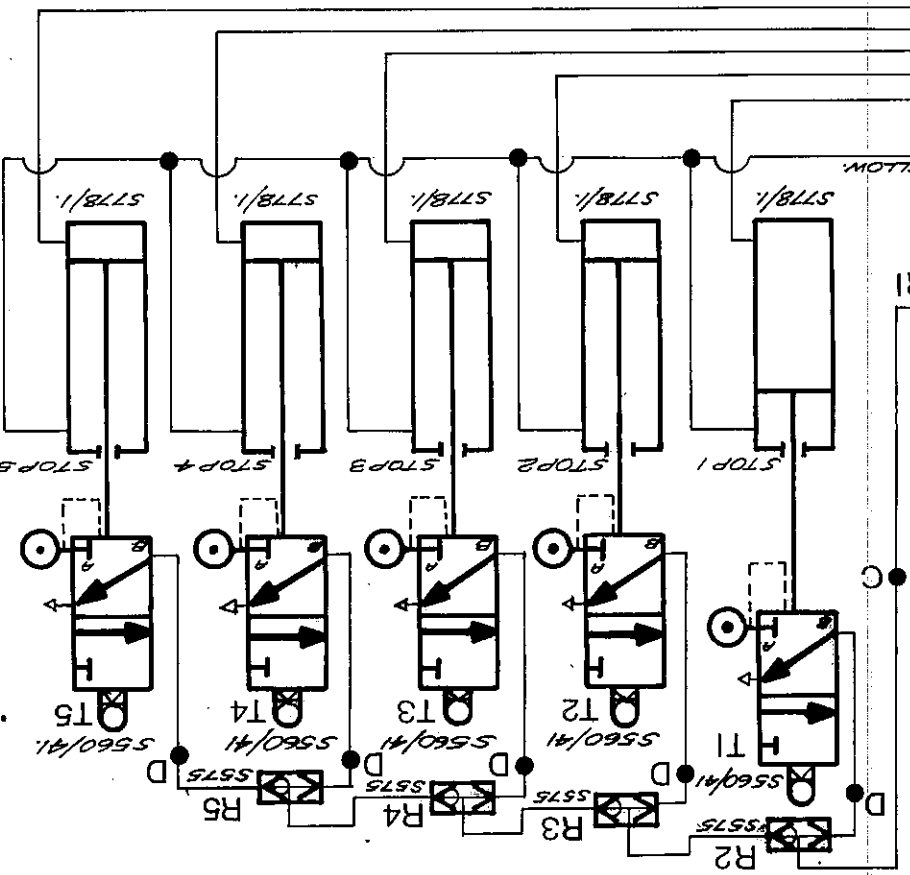
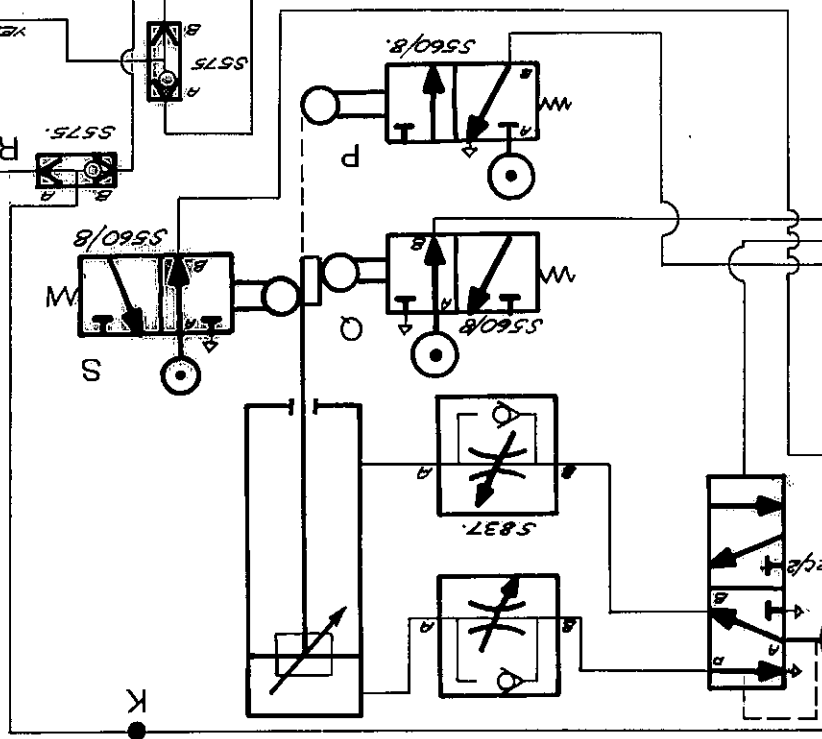
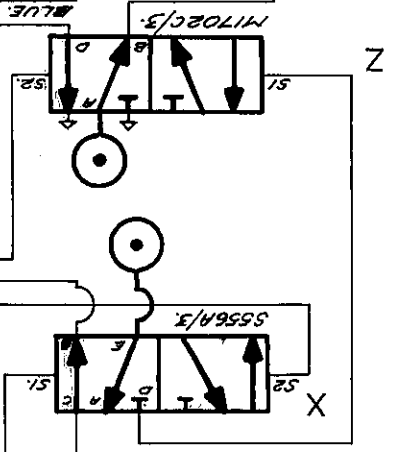
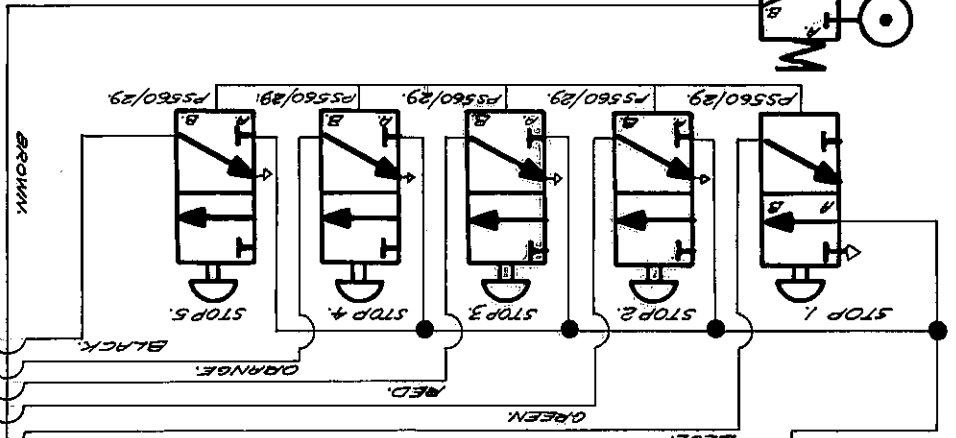
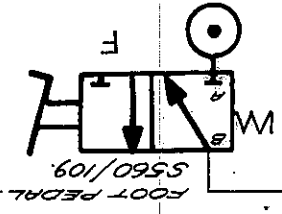
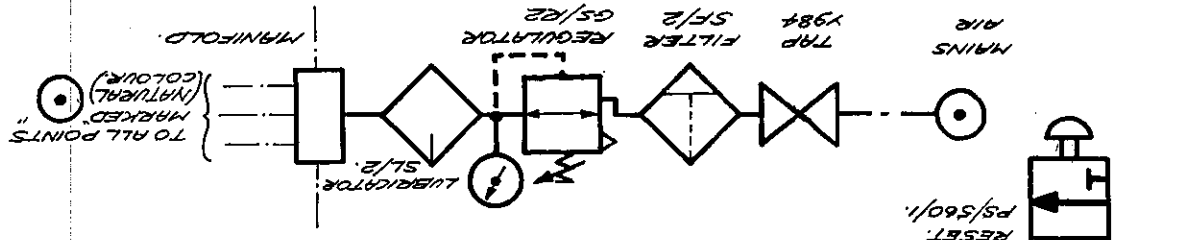

AIR SYSTEM WORKING PRESSURE 80-100 P.
MAINTENANCE REFERENCES C.E.T.O.P SYMBOLS.
APPLIES TO MACHINES 74761 ONWARD.

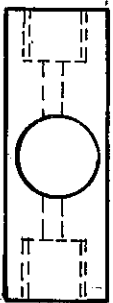

5

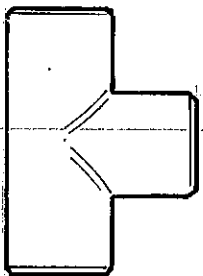

3

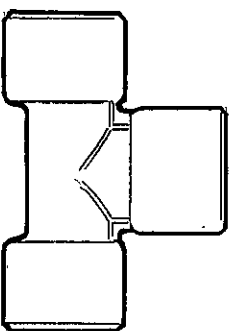

2

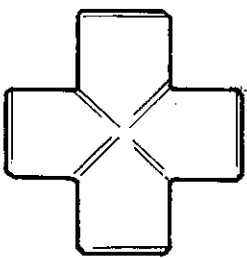

27

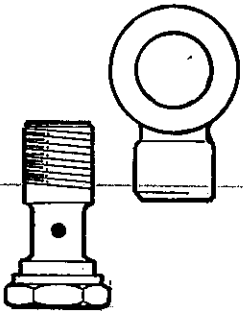

12

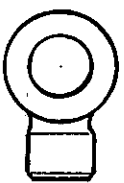

10

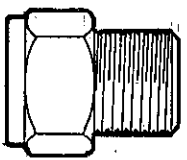

22

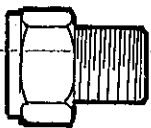

17

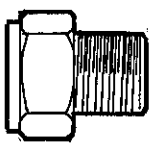

18

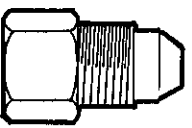

8

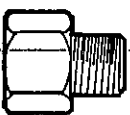

15

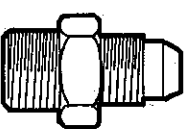

6

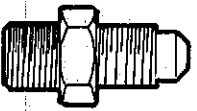

7



16

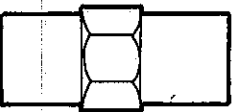

14

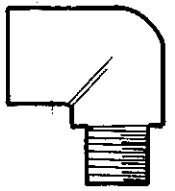

26

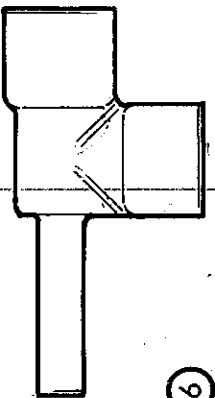

9

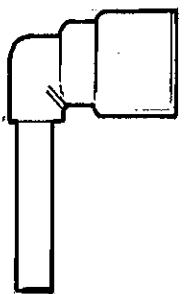

21

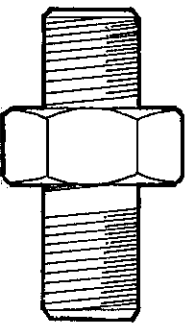

19

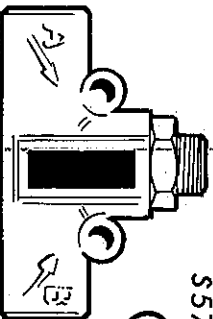

4

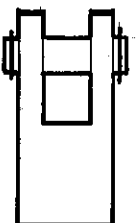

QM 401.



28



29



32



33

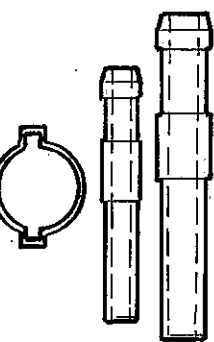

24



23



25

THE CIRCLED REFERENCE NUMBERS GIVEN TO EACH ILLUSTRATION ON PAGE ARE FACTORY IDENTITY CODES AND THEREFORE THE LIST GIVEN BELOW IS CROSS REFERENCED TO THESE CODES RATHER THAN BEING IN NUMERICAL ORDER. ALTERNATIVE ENOTS SERIAL CODES ARE GIVEN ONLY WHERE APPLICABLE.

WORKS CODE	MARTONAIR LTD. REF.	ENOTS LTD. REF.	DESCRIPTION
5	S72/33	-	DOUBLE BANJO.
3	S68/3	34029004	1/4 TEE
2	S68/4	34029005	5/16 TEE
27	S85/4	-	FOUR WAY CONNECTOR.
{12	S71/4	-	5/16 SINGLE BANJO WITH 5/16 BANJO
{13	S71/4	-	BOLT SUPPLIED AS A SET PAIR. }
{10	S71/33	-	1/4 SINGLE BANJO WITH 1/4 BANJO }
{11	S71/33	-	BOLT SUPPLIES AS A SET PAIR. }
22	S65/45	34034625	STRAIGHT CONNECTOR.
17	S65/4	34034617	5/16 STRAIGHT CONNECTOR.
18	S65/3	34034616	1/4 STRAIGHT CONNECTOR.
8	S66/3	34035239	REDUCER.
15	S65/33	34034609	STRAIGHT CONNECTOR.
6	S70/4	34035017	ADAPTOR.
7	S70/33	34035009	ADAPTOR.
16	S86/33	34034409	FEMALE STRAIGHT CONNECTOR.
14	S64/3	34000704	TUBE CONNECTOR.
26	-	34033009	90° ELBOW.
9	S83/3	34034104	SIDE STEM CONNECTOR.
21	S81/3	34005704	STEM ELBOW CONNECTOR.
19	S/C52	-	FLAT UNION.
4	S575/C	-	SHUTTLE VALVE.
-	QM401	-	AIR CYLINDER FORK END.
28	10914/4	34027805	5/16 OLIVE.
29	10914/3	34027804	1/4 OLIVE.
30	6822/4	34027905	5/16 NUT.
31	6822/3	34027904	1/4 NUT.
32	S/P7540	48021302	5/16 ALLOY WASHER.
33	S/P6589	48021301	1/4 ALLOY WASHER.
24	8030	34005605	TAILPIECE.
23	8029	34005604	TAILPIECE.
25	14449	48016804	HOSE CLIP.

SPARE PARTS		STOCK LIST	
DESCRIPTION	QUANTITY PER M/C	IDENTITY REF. CODE	REMARKS
SPINDLE BEARINGS.	2	SKF 6307	-
SPINDLE HOUSING PIVOT BEARINGS.	2	SKF RL14	-
V - BELTS.	3	ALPHA 530	5.5 HP M/C.
V - BELTS.	3	ALPHA 560	7.5 HP M/C.
STOP AIR CYLINDER PIVOT SCREWS.	6	-	WITH LOCKNUTS.
AIR CYLINDER FORK END.	2	QM 401	-
STOP BRASS PIVOT PIN.	2	BCW 69	-
STOP RETURN SPRING.	2	BES 25	-
STOP AIR CYLINDER.	1	M778/25	-
ROLLER VALVE.	1	S560/8	-
TRIGGER VALVE.	1	S560/41	-
SHUTTLE VALVE.	2	S575/C	-
1/4 DIA. NYLON AIR PIPE.	20 metres	-	-
5/16	20 metres	-	-
1/4 NUTS.	20	6822/3	-
1/4 OLIVES.	20	10914/3	-
5/16 NUTS.	10	6822/4	-
5/16 OLIVES.	10	10914/4	-
1/4 SOFT ALLOY WASHERS.	20	S/P6589	-
5/16	10	S/P7540	-
TUBE CONNECTOR.	2	S64/3	-
CONTACTOR.	K16	BROOK RT3-RYD	(STATE VOLTAGE)
OVERLOAD UNIT.	U16	(.)

FOR ANY OTHER TYPE OF ELECTRICAL SUPPLY CONTACT BURGHEEN (COLINE) LTD.
 QUOTING DETAILS AND FULL PARTICULARS

AIR SYSTEM SERVICE NOTES AND DETAILS.

DETAILS BY KIND PERMISSION OF



Port Identification Code

The port markings of pneumatic valves, regulators etc., have in the past, varied considerably throughout the industry, each manufacturer adopting his own method. In the absence of a universally accepted method, Martonair has for many years used the letters 'A', 'B', 'C', etc. to identify the main inlet, outlet and exhaust ports, and the letters 'S', or 'S1' and 'S2' to identify the pilot control ports. Recently, new proposals have been put forward by CETOP, the European fluid power manufacturers' association for a universal method of port identification. The CETOP code has been submitted as a proposal for official ISO and BSI standards, and we feel that brief details will be of interest to our customers.

These new proposals are essentially numerical as shown in the example above. The code is intended to assist the user in connecting up circuits by relating the port markings on the circuit diagrams to those on the valve and to give a clear indication of the normal function of each port on the valve and is primarily intended for valves with up to 5 main ports. Combinations of numbers and letters are used to identify these ports, mainly the digits 0, 1, 2, 3, 4 and 5. Auxiliary supply and exhaust ports to the pilot operator are identified by a letter X or letter Y respectively together with the number of the outlet port it controls.

The main ports are identified as follows:—

- 1 = Normal inlet i.e. main supply port.
- 2 = Normal outlet port on 3/2 and 3/3 valves.
- 2 & 4 = Normal outlet ports on 5/2 and 5/3 valves.
- 3 = Normal exhaust port on 3/2 and 3/3 valves.
- 3 & 5 = Normal exhaust ports on 5/2 and 5/3 valves.

Port 1 is the main supply port, other odd numbers denote exhaust ports, and even numbers outlet ports. Port 3 is always internally connected to port 2 when the valve is in one position. In the reverse position on a 5 port valve port 5 is always connected to port 4. See figure 1.

The pilot control ports are identified as follows:— '10', '12', and '14'.

These references comprise the marking for the main supply port, namely '1', and the port to which it is connected when the pilot port in question is operated. Therefore, '10' indicates a pilot port which when operated isolates the main supply port. Pilot port '12' connects the main supply to outlet port '2' when operated and in the case of pilot port '14', port '4' is connected to the main supply. Where a position is achieved automatically by the valve itself, e.g. spring return, no marking appears on the symbol. These references also apply to other means of operating the valve besides pressure. See figure 2.

Figure 3 illustrates a number of typical valves with the proposed port markings

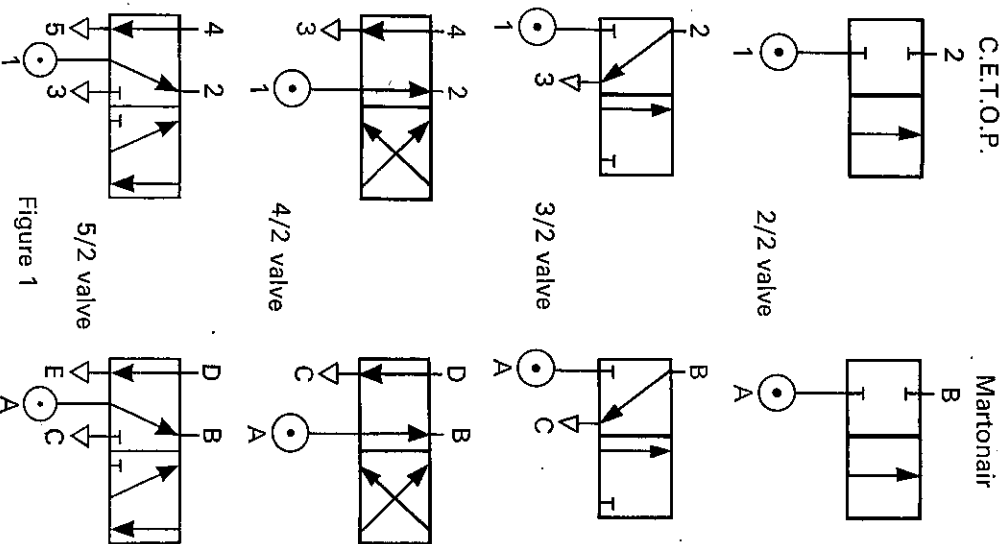

Figure 1

General Service and Maintenance Instructions

Valves

The main cause of failure of pneumatic valves is leaking 'O' Rings. When operated on a clean, dry and lubricated air supply, within their pressure and temperature specifications and not subjected to excessive mechanical forces, etc., valves in general will have a working life between servicing periods of approximately 10 million cycles. If a valve requires servicing before 5 million cycles, then check the installation, environmental and operating conditions most carefully as these will most likely be the cause of the shortened working life. The usual cause of this is abrasive particles entering the valve and causing excessive wear on the 'O' Rings. For this reason it is essential to have a filtered, lubricated air supply to ensure that no dirt particles get into the valve and to reduce the normal wear to a minimum. Martonair filters and lubricators provide the answer to this problem. Use only piping of a noncorrosive type, such as copper or nylon.

The filter extracts all the dirt particles in the airstream down to a size of 25 microns. Not only this, however, because of its centrifugal action it virtually eliminates all the moisture in the air as well.

To keep the moving parts adequately lubricated, it is essential that a suitable lubricant is introduced into the valve via the air supply and that it should be in the correct form and quantity. This can be easily obtained by fitting a Martonair Lubricator into the air line upstream of the valve and as close to it as possible. The lubricator should be fitted downstream of the filter.

Testing for leaks

To check if a valve is leaking, remove it from the circuit and connect the inlet port to mains air supply, suitably filtered, lubricated and regulated. In the case of a 5-port valve, the cylinder ports should each be connected to a pressure gauge and air reservoir if possible. If circumstances make this impossible, however, an alternative method is to connect the valve to a double-acting cylinder of a

suitable size, in the case of a 3-port valve this should be a single-acting cylinder, having first ensured that the piston of the cylinder does not leak. (Refer to "Testing Cylinders", pp. 5).

With the air supply switched on, operate the valve several times. After operating, check that the valve is not leaking at each of the alternative positions by partially covering the 'idle' exhaust port with the hand or finger and putting a film of oil across the small remaining orifice and observing any tell-tale bubbles which may appear. Concentrate the port in this way covering the leakage, if any, at one small point, thus making it easier to detect. With 3-port valves there is, of course, only one exhaust port to check.

If the valve is of the supply-sealed mid-position type, it will also be necessary to check the mid-position in the same way.

In the case of fully-sealed mid-position valves, test across the exhaust ports as above then the cylinder port connections should be removed and the above tests made at the cylinder ports also.

Actuate the valve again and retest.

Other forms of leaks shown up by these tests are those caused by scoring, scratches, pitting etc., on the valve body or bush and damaged 'O' Ring grooves in the piston.

If any faults are evident on test, strip the valve and examine it. Reassemble the valve, ensuring absolute cleanliness, and repeat the above tests. It is advisable to test at both low and high catalogue air pressure figures.

It is recommended that all seals are replaced at the same time rather than individually as and when they wear out. This recommendation applies to all Martonair equipment. If the leak is caused by a damaged bore finish then the body or body bush, as determined by the valve design, must be replaced.

Other probable causes of valves failing to operate correctly, in the case of spring, air or spring and air return valves, are blocked bleed holes in the pistons and jammed springs. To check this, connect the

valve up to the air supply in the same way as described above and operate as before. The return should be snappy and any sluggishness is indicative of the above faults. This can be put right simply by cleaning the piston bleed holes, if blocked, (ensuring that the very small holes in the bleed valves' pistons are not enlarged at all) and in the case of a valve using a spring, by lubricating the spring and removing any physical obstruction if necessary. Occasionally ineffective operation is caused by a spring which has become weak with use, in which case it is simply removed and replaced with a new one.

Valves can also be damaged, in particular their operating mechanisms, by incorrect installation and operation; excess force on the operating mechanism, for example, could cause it to become distorted, and this should also be checked if the valve is not functioning properly.

Main types of valves

For the purposes of servicing, valves can be divided into four main types:—

PISTON—This is the most common type of valve. The piston carrying sealing 'O' Rings moves along a bore in the valve body, opening and sealing the various ports according to its position in the body.

The basic construction of these valves consists of a valve body and bush assembly, or, in the case of most $\frac{1}{8}$ " B.S.P. size valves, a valve body only, having a bore into which is fitted a piston assembled with 'O' Ring type seals. Various port connections and inter-connecting arrangements are employed but servicing is essentially the same for all types. The basic body and piston arrangement is shown in exploded form in Fig. 1.

POPJET—Fundamentally, the servicing of poppet valves is the same as piston types. The main difference is in the piston arrangement (see Fig. 2).

Instead of having a piston that is fitted with 'O' Rings at certain points along its length to enable the ports to be opened and closed, the piston in a poppet type valve rests against a seat, sealing the

flow from the inlet port to the outlet (cylinder) port. Operating the piston closes the exhaust and removes the piston from its seat, thus connecting the inlet port to the cylinder port. When the piston is returned to its seat, the pressure of the exhausting air opens the exhaust port and so escapes. Only a very small operating movement is required to achieve a very high rate of flow, in some designs, in fact, considerably higher than can be obtained with a piston type valve of similar size. A servo type operation, giving an output directly proportional to the pressure applied to the operating mechanism, can be obtained in some models. The principle, however, can only be applied to 3-port valves.

PLATE—The basic construction of these valves is a body into which is fitted a circular plate having a hole bored through it which enables air to be connected from the inlet port to one or the other of the cylinder ports. Two slots connect the 'idle' cylinder port to its exhaust port. The inlet port is situated in the body, whilst the cylinder and exhaust ports are situated in the top cover. The plate is seated against the face of the top cover and turning the handle revolves the plate, thus connecting the hole and the slots in the plate to the appropriate holes in the top cover.

It is possible to achieve a certain degree of flow regulation with this valve, without the need for external flow regulators, making it suitable for the control of double-acting cylinders and similar devices. By variation of the angular movement of the handle, ranging from a creep to full bore. All ports are isolated in the mid-position.

SOLENOID—Solenoid valves are 3-port, glandless valves which are operated by energising a coil situated around a core fitted with two seats. When the coil is energized, the core is raised off its seat against the force of a light spring, thus allowing air to pass from the inlet port to the outlet (cylinder) port, and sealing the exhaust by means of another seat at the top of its movement. When the coil is de-energized, the spring returns the core to the bottom seat, sealing the inlet and allowing the exhaust to escape up the side of the core and out through the port at the top. In the case of a 'normally closed' valve the inlet port is at the top, otherwise procedure is the same. Fig. 3, shows a typical solenoid valve.

It is also extensively used as a pilot operator for larger valves.

SERVICING MARTONAIR VALVES

Piston types

CLEANING

The valve should be removed from the circuit before being dismantled. Detailed instructions for dismantling each individual stroke of valve are obviously beyond the scope of a small set of leaflets such as these, but they can, however, be found in the Martonair publication "A Service Course in Pneumatics".

The valve body should first be thoroughly degreased in detergent and then cleaned in paraffin. Pipe fittings are left on unless their threads have been stripped or otherwise damaged, in which case they should be removed, the ports cleaned of all sealant, etc., and new fittings attached. If jointing compound is used, care must be taken to ensure that none is allowed to enter the internal passages of the valve body.

EXAMINATION

Check the mechanism and base securing holes to see that the threads have not been stripped. If damaged it will be necessary to replace the body.

Examine the bore or bush of the valve body to make sure it is free from score marks, scratches, pitting, etc. If the bore is damaged in any way it is advisable to replace the body completely.

In addition to the main and pilot ports, some valve bodies have small integral pilot supply holes and these should be checked to see that they are not clogged up and also that the sealing 'O' Ring or gasket faces are not damaged. These pilot supply holes must be completely cleared using a piece of stiff wire and the sealing 'O' Rings or gaskets replaced with new ones as necessary. Where fitted, the small inlet filters should be removed and thoroughly cleaned before refitment.

The 'O' Ring seals on the valve piston should be removed by hand and should always be replaced by new seals. Before fitting replacement seals, thoroughly degrease piston and examine the 'O' Ring grooves for scratches. The piston should be unmarked, but at this point check carefully the ends of the piston as these are sometimes damaged by mechanical hammering if the pilot holes have been enlarged or if too high a pressure has been used, during operation.

In lever bleed and air return valves check to ensure that the small drill holes in the piston are clear and not clogged in any way. Clear the holes

through with a stiff wire. **UNDER NO CIRCUMSTANCES MUST THESE HOLES BE OPENED UP BY DRILLING.**

After fitment of new 'O' Rings thoroughly grease all piston rings with recommended grease.

SERVICING SPRINGS

In spring return models, after removal of top mechanism, the spring will be loose in the valve body and can be easily withdrawn. If difficulty occurs, however, leave the spring in position and remove the bottom cover. The bottom cover can be released by removing the fixing screws. Remove spring and thoroughly clean bottom cover and spring locating pin, where fitted. If the pin is not square with the base or is rusted or otherwise damaged, extract and fit a replacement, ensuring that it is square with the base before placing in position. An out-of-square pin will cause the spring to jam.

REASSEMBLY

If the bottom cover has been removed during servicing of the spring, reassemble with screws provided, locating the spigot in the recess and stand the right way up on the workbench.

Next fit standard spring into body and onto the pin or the bottom cover recess. Apply recommended grease liberally to the whole of the spring before assembly.

The unit is now ready for fitment of the piston and the operating mechanism. In final assembling, make sure that the spring is locating properly in both the piston bore and the valve base pin or recess. Hold the top cover down against the action of the spring, locate the cover spigot in the body recess and fit retaining screws. The unit is now ready for testing—at both low and high pressures—as previously described.

SERVICING MARTONAIR CYLINDERS

Main causes of failure

The main causes of failure of pneumatic cylinders can be attributed to worn or damaged seals. When used with dry, clean, and correctly lubricated air and not subjected to any abnormal operating stresses, cylinders will have a normal working life in excess of either 5 million feet total movement or 5 million cycles, whichever represents the shorter total distance travelled, and should not require servicing before this time.

Dismantling cylinder

Dismantle the cylinder, ensuring that the tie rods are loosened in the order 1, 3, 2, 4 (see fig: 4A) and thoroughly degrease. It should not be necessary to remove the piston from the rod during normal service, but in the event of one or the other being badly damaged, the piston can be removed from the piston rod, ensuring that the locking device is removed, and that the correct tool is used. This locking device is either a pin or a grub screw. If no device is fitted, then Loctite 'C' has been used.

Seals

Examine all seals for wear. If the seals are worn, it is advisable to replace all the seals at the same time with new ones. Cushion seals and piston rod seals/packings should be fitted with the lip facing into the cylinder. On some cylinders it is necessary to remove the piston rod bearing from the front end cover to replace the piston rod seals/packings. When fitting piston seals, the seal nearest the piston rod should be fitted first, the piston inserted in the barrel so that the seal enters heel first and pushed through the barrel until the empty groove is just protruding from the end of the barrel, making sure that the first seal remains inside, and the remaining seal fitted and the whole assembly now drawn into the barrel. **DO NOT** try to insert piston seals into the barrel lip first as they will become damaged. When fitting or removing seals, never use a sharp instrument and take care not to damage the seal or seal groove. When replacement cushion seals have been fitted, ensure that the seal retaining slips (if fitted on the type of cylinder being serviced), are correctly fitted into the recess on the piston. Failure to do this can result in the cushion seal rolling over, causing damage and loss of cushion effect.

Barrel, piston rod and piston rod bearing

Examine the barrel, piston rod and piston rod bearing and seal retaining rings for scoring, scratches, rust, etc., very carefully. Slight imperfections can be removed by polishing with fine (flour) emery paper. Also remove any burrs or sharp edges on piston rod. Provided any marks now blend smoothly into the overall finish, the components will be satisfactory. If deep score marks are noticed, however, the component will have to be scrapped because although the rough edges can be polished to

blend in with the overall finish the seal cannot prevent air escaping via the deep groove of the score mark. It is best to polish radially with fine emery paper and finish with very fine, applying lubricating oil during the final polishing operation. On hard chromium plated items, it will be necessary to use fine oil stone, or diamond lap, for smoothing during the final polishing operation. If the plating is extensively damaged, it will be necessary to return the part to the factory for full servicing and plating. If the barrel itself has been badly damaged it must be replaced.

End covers

When cleaning end covers take great care not to damage the barrel location spigot against which the barrel is sealed. Remove cushion screw and check that the screw's needle point is not damaged. Renew if necessary and replace with new sealing 'O' Ring. To check for sealing, screw the cushion screw in fully, fill the air transfer hole on face of end cover with light oil. The level should not fall unless the screw is screwed out slowly. This test will prove that the screw profile and seating in the end cover are satisfactory. If the test has a negative result, it will be necessary to examine the end covers and cushion screw and replace as necessary.

Thoroughly clean the non-return valve ball in the end cover using a blow gun, checking that it is not damaged and that it moves freely and seals on its seating. To check sealing, rest the end cover so that the ball is resting on its seating and pour a few drops of paraffin or very thin oil into the ball recess until it is full. If the liquid remains, or the level only drops very slowly, then the sealing will be satisfactory. If, however, the liquid pours quickly through, it will be necessary to remove the retainer pin, repolish the seating, replace and retest. If the seating is badly damaged, send it back to Martonair for a seat recut. (Not all Martonair cylinders are fitted with this cushioning device.) Lubricate the cushion screw and replacement 'O' Ring with a recommended grease and fit back into the cushion hole. Lightly screw fully in and then unscrew half a turn.

Pipe adaptors need not usually be removed from end covers, but if they have been damaged, then they should be removed, and a new component fitted. In extreme cases it will be necessary to replace the whole end cover assembly if it has been damaged at the port by overtightening the fitting.

Check end cover/cylinder barrel washer or seal, and replace if worn or damaged.

Bearing liner

Examine the bearing assembly for marks and treat as cylinder barrel above. Also examine for wear. If play exceeds .004" for rods up to 1 1/4" dia. or .006" for larger diameters the bearing liner should be replaced. Excessive wear on one side of the bearing indicates that the cylinder is subjected to considerable side thrust and the installation of the cylinder should be carefully inspected and the cause removed. The bearings can be either the Glacier Bush type or the Nyliner type.

Reassembly

Before reassembling the cylinder, thoroughly grease the inside bore (prior to inserting the piston in the manner previously described) with a recommended grease and liberally apply to the outside lips of piston seals and cushion seals prior to assembly.

Assemble new 'O' Rings or gaskets on to the cylinder barrel location spigot of the rear end cover. Fit barrel snugly on to the cover spigot. Slide central trunnion (style H) over barrel if fitted and then slide front end cover and bearing assembly complete with new 'O' Rings or gaskets over the piston rod and fit snugly into place. Ensure that the ports are positioned correctly.

Bearing housings

Where the bearing housing is fitted to the end cover by means of the cylinder tie rods, it will be necessary to fit the piston rod packing over the piston rod (lip inwards)—taking care not to damage it—and then the bearing housing, including wiper seal if fitted internally, on to the rod and finally mating the housing spigot into the recess provided in the front end cover. Lightly oil the rod with standard lubricant before assembling the housing on to the rod, similarly grease packing. Having checked the rods for damage, these can now be fitted and mountings replaced as positioned prior to disassembly.

On cylinders where the bearing housing is fitted to the end cover by separate screws, fit as follows:

Minor cylinders and S.900 series

Fit greased piston rod seal on to the rod and locate in front end cover recess, lip inwards. Fit wiper seal

into the bearing housing (lip *outwards*) and slide onto slightly oiled rod, screwing into position. NOTE: Where the piston rod has an unshouldered thread (style Y) care must be taken not to cut the seals on the thread.

S.1000 series and S.9140, S.9141 and S.9142

Fit the bearing washer and sealing ring by passing over the rod and into the front end recess, after which the bearing can be slid on to the rod, which has been lightly oiled, and screwed to the end cover. The piston rod seal should be greased and fed over the rod into the housing recess, lip facing inwards. Next fit wiper seal housing, wiper seal (lip facing *outwards*) and wiper seal retaining ring in order and clip into position.

Testing cylinder

Connect the cylinder to a five-port valve which is connected to mains air supply (60-100 p.s.i.g.), operate valve six times in succession to make the cylinder reciprocate for its full stroke. Leaving the cylinder in the 'outstroke' (+) position, test rear end cover/cylinder barrel connection for leaks by painting with oil or soapy liquid. Check the cushion screw hole in similar fashion. If leakage occurs, the liquid will froth and bubble. If so, check that the tie rods have been tightened down sufficiently and evenly, and correct accordingly.

Check at the operating valve to see if air is escaping from the front end cover exhaust port in a continuous stream. If so, the rear piston seal is damaged or incorrectly assembled, or there is a flaw in the cylinder barrel surface finish in which case it will be necessary to strip the cylinder down again and examine to clear the fault. The valve, of course, should not be leaking in any way.

Operate the valve and fully retract the piston (—) and check the front end cover in the same way as for the rear end cover previously. In this case, continuously escaping air at the rear end cover exhaust port indicates that the front piston seal is at fault, or that the barrel is damaged. Correct as above. Also check that the bearing assembly is not leaking by using oil or soapy liquid.

During these tests the cylinder should not be cushioning at the extremes of stroke as the cushioning screw should have been adjusted to lose cushioning.

Having completed the leakage tests, check that the cushioning is operating correctly by screwing '1N' to check the degree of cushioning and screwing 'OUT' to ensure loss of cushioning. When screwed '1N' the cylinder will often be prevented from fully stroking and if this occurs the cushion will be quite excellent and in all cases the final cushion movement should be extremely slow (much less than $\frac{1}{2}$ " / sec.).

With the cushion screw in the fully 'OUT' position (usually 3 reverse turns from fully '1N') cylinder speed should be only slightly reduced on final piston movement. Speed at commencement of strokes, both + and —, should be smooth and uniform. If the non-return valve is not working properly this will be apparent by jerky acceleration. N.B. Non-return valves are not fitted to all types.

These tests should be repeated at a lower pressure setting (30 p.s.i.g. if possible) with the piston rod rotated with a tommy bar to positions of 90°, 180°, 270°, and 360° to check for any eccentricity.

If all tests are satisfactory, the cylinder can be returned to the circuit. When in place check the port air line connections for leaks using oil or soapy liquid before putting the cylinder into operation.

Figure 4 shows the basic components of a cushioned, double-acting cylinder.

NOTE: WHEN ASSEMBLING PNEUMATIC CYLINDERS IT IS ESSENTIAL THAT EVERYTHING IS KEPT SCRUPULOUSLY CLEAN.

SERVICING MARTONAIR AIR LINE EQUIPMENT

Air line equipment, generally, requires very little maintenance and the following servicing procedure every six months will, in most cases, be completely adequate.

Filters

When the red indicator band appears permanently above the black band on the bowl of the filter, it is necessary to either change the filter element, or clean it.

First drain any sediment from the reservoir and depressurize the unit. Then remove the bottom cover and barrel, together with the sealing gaskets at each end of the barrel and remove the filter element sub-assembly, see Fig. 5. To clean the element it is only necessary to

wash it in any standard detergent. Before reassembling make sure that all internal parts are clean. The barrel may be cleaned with paraffin oil or weak detergent. DO NOT CLEAN WITH ANY TYPE OF DEGREASING FLUID OR WITH CARBON TETRACHLORIDE.

Replace filter element, barrel and bottom cover using new gaskets.

Lubricators

Under normal conditions draining of the oil reservoir to remove sediment need only be carried out at six monthly intervals, otherwise the following annual service is all that is required.

First drain oil from reservoir and depressurize unit. Remove top cover and gasket and inspect poppet valve 'O' Ring, replacing if badly worn. Replace top cover with new gasket. Remove bottom cover, barrel and 'O' Rings or gaskets as appropriate, see Fig. 6. As it is impossible to ensure the correct setting of the cartridge assembly or jet screw, according to type, without calibration on no account must it be tampered with, but that a clean, high pressure air line be connected to the bottom of the oil pick-up tube to ensure that the jet is clear. Clean filter with paraffin oil after removal from pick-up tube. Before replacing filter, ensure that the bore of the tube is clean. *This is very important.*

Clean reservoir with paraffin oil or weak detergent. DO NOT USE ANY TYPE OF DEGREASING FLUID OR CARBON TETRACHLORIDE.

Replace reservoir and bottom cover with new 'O' Rings or gaskets accordingly.

POWER FEED MACHINES - MODELS BCW/R/F & BCW/L/F

Further to the standard machines described which are of the hand fed type, air operated top and bottom nip rollers are fitted to the above versions in conjunction with special power roller table type XMP to create power feed models.

This feed system consists of a top idler air operated nip roller which has hand adjustment to compensate for varying timber sizes and a bottom power driven air operated nip roller which provides the feed drive.

Both rollers are pivoted and being air operated can engage or disengage their drive in sequence with the action of the saw and stops. Restrictors are fitted (M836) to control the speed of the nipping action.

To isolate the nip rollers, when requiring to hand feed only, simply operate push button on main machine panel.

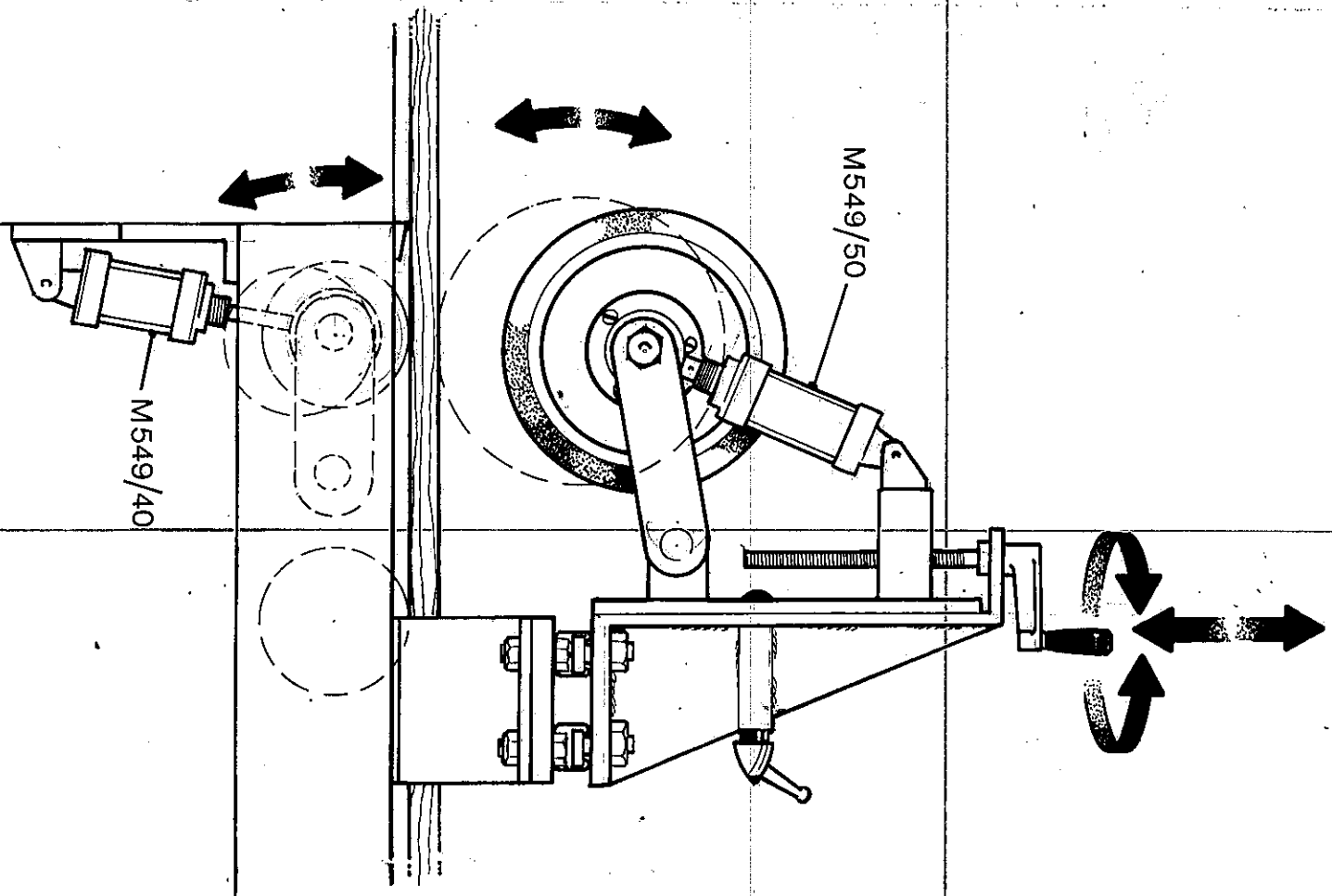

HEALTH & SAFETY

SAFETY OF WOODWORKING MACHINES

Woodworking machines can be dangerous if improperly used. The wide range of work of which they are capable, requires adequate safeguarding arrangements against possible hazards.

Many injuries to machinists are caused by carelessness or failure to use the guards provided or to adjust them correctly.

WADKIN LTD., supply machinery designed for maximum safety which they believe, as a result of thorough testing, minimizes the risks inevitable in their use. It is the user's responsibility to see that the following rules are complied with to ensure safety at work:

1. The operation of the machine should conform to the requirements of the Woodworking Machines Regulations 1974. All guards should be used and adjusted correctly.
2. Safe methods of working only should be adopted as given in the Health and Safety Work Booklet No.41, "Safety in the Use of Woodworking Machines", (obtainable from Her Majesty's Stationery Office) and as advised by Wadkin Ltd.
3. Only personnel trained in the safe use of a machine should operate it.
4. Before making adjustments or clearing chips, etc., the machine should be stopped and all movement should have ceased. ISOLATE MACHINE
5. All tools and cutters must be securely fixed and the speed selected must be appropriate for the tooling.

SAFETY IS OUR WATCHWORD BUT THE USER MUST COMPLY WITH THE ABOVE RULES IN HIS OWN INTEREST. WE WOULD BE PLEASED TO ADVISE ON THE SAFE USE OF OUR PRODUCTS.

000

WADKIN LTD · GREEN LANE WORKS · LEICESTER LE5 4PF · ENGLAND · TELEPHONE 0533 769111
and York House Empire Way, Wembley, Middlesex HA9 0PA Telex: 36646 (Wadkin Leicester)
Telephone: 01-902 7714 Telex: 262210 Telegrams: Woodworker Leicester Telex

**INFEED\OUTFEED
POWER\IDLE
ROLLER TABLE
& CONVEYORS.**

MEDIUM DUTY IDLE ROLLER TABLE TYPE	XMM
<p>The standard unit supplied to order stations on the machine consists of support legs and rollers mounted at intervals, these extra units being fitted and bent over to secure in place.</p>	<p>for both infeed and outfeed a 2.5 meter length fitted with 254 mm intervals. The table side roller spindle units (ie) 127 mm to extra rollers are "filling in stock."</p>
<p>ROLLER & SPINDLE UNIT REMOVAL</p>	
<p>To remove a roller unit for replacement simply pull out the retaining split pin fitted through the spindle and withdraw spindle from side frame. To replace reverse above procedure ensuring split pins are re-fitted and bent over to secure in place.</p>	
<p>CONNECTING TABLES TOGETHER</p>	
<p>Where further 2.5 meter lengths are required the tables can be linked together by using the top plate of the support leg as a strapping piece (ie)</p>	

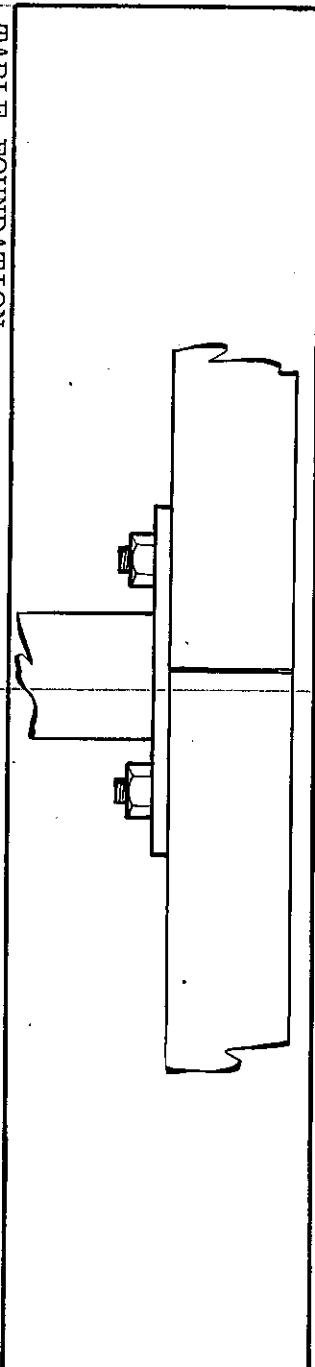

TABLE FOUNDATION

Under normal circumstances this lighter type of table can be left free standing to the machine. However, if so required the whole table unit may be bolted down in the normal manner.

NOTE:- IF ORDERING SPARE PARTS PLEASE QUOTE
"TABLE TYPE XMM"

AIR OPERATED STOCK GUIDES (POWER FEED MACHINES ONLY)

A maximum of three guides can be fitted to any one machine, their object being to keep the stock upto the stops, especially long lengths.

The guides work in sequence with the saw and stops and will raise to allow timber to be ejected by the ejectors as soon as the saw cut is completed.

The guides are fully adjustable both longitudinally and laterally and have rigid locks.

To isolate the guides when not required operate valve button situated on the guide body rear.

We recommend that all pivots are cleaned and lubricated regularly.

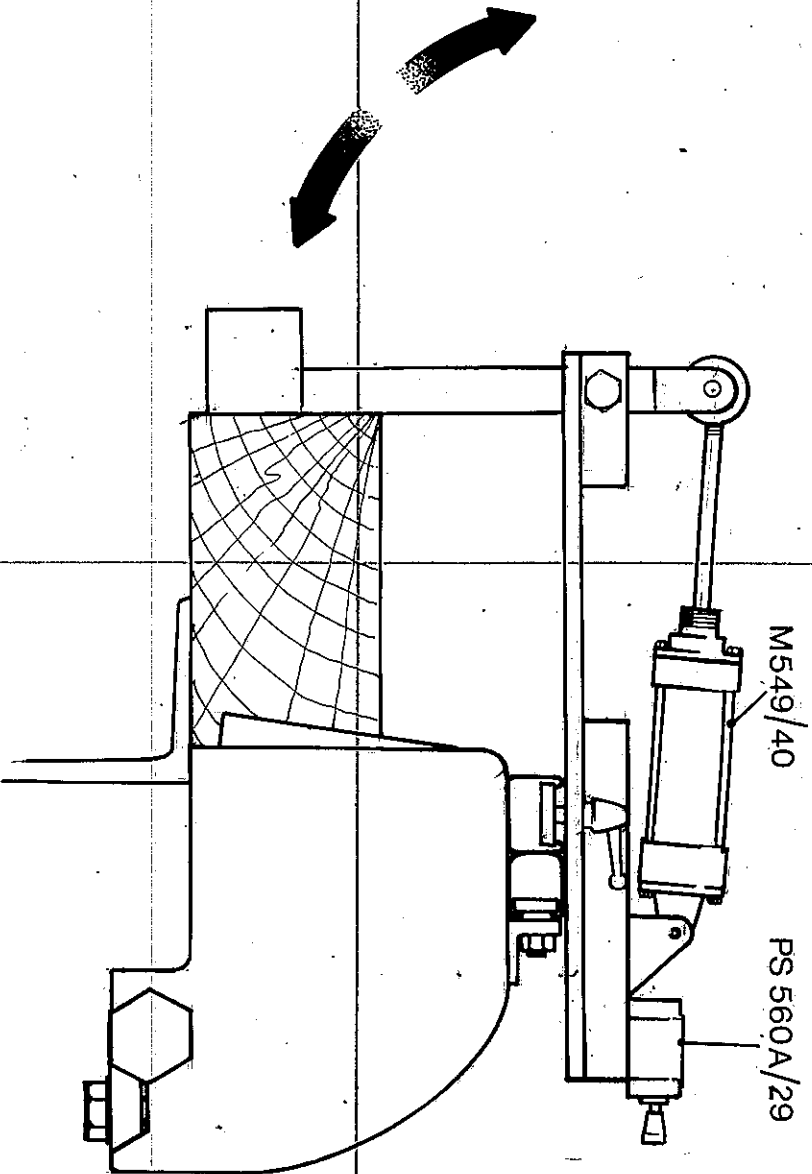

STOP DEFLECTOR PLATES (FOR USE ON ALL MODELS IF REQUIRED)

Deflector side plates can be fitted to the stop body casting to assist guidance of timber onto the stop trigger. On power feed machines deflector plates are fitted as standard.

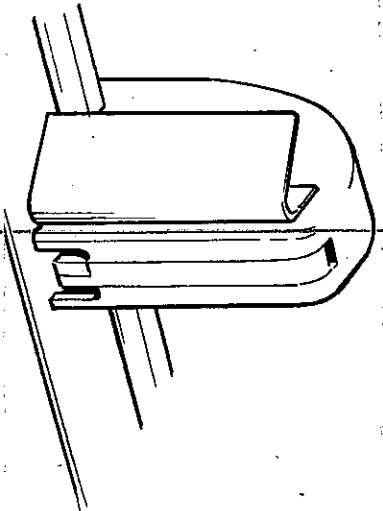

VARIABLE SPEED POWER ROLLER TABLE

XMP

Intended for use on the infeed side of the machine this unit has chain driven rollers from a 1HP variable speed drive unit which gives speeds from 18.3 to 73.1 metres per minute.

MAINTENANCE

Drive chains:- (½" PITCH REF 110046) Ensure all chains are clean and well lubricated. Suspect chains and sprockets should be replaced. DO NOT LEAVE CHAIN GUARD COVER OFF

Check condition of rollers and replace any badly damaged ones. (Individual roller, spindle and bearing units are available direct from the factory)

Variable speed drive:- This unit should be lubricated and maintained in accordance with the instruction plates fitted to the unit.

FOUNDATION

This unit is fixed to the machine and should be bolted down and levelled up (ie)

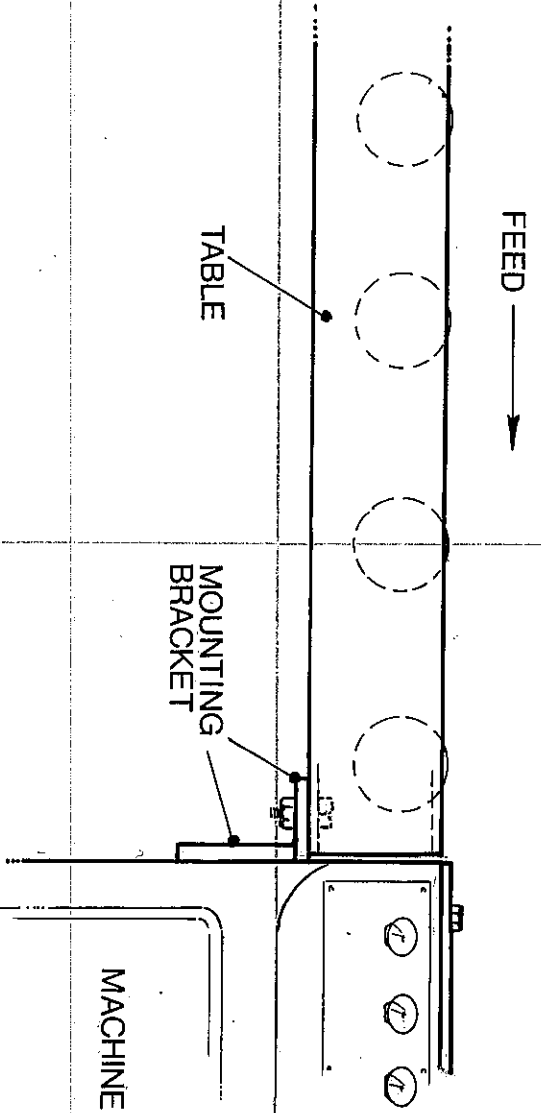

NOTE WHEN ORDERING SPARES QUOTE

"TABLE TYPE XMP"

HEAVY DUTY VARIABLE SPEED POWER BELT CONVEYOR TYPE XMB

Intended for use at the outfeed end of the machine this unit has ball bearing mounted spindles driven by chain from a 1 HP variable drive unit giving speeds from 18.3 to 73.1 meters per minute.

MAINTENANCE

Roller chain drive:- (Chain $\frac{3}{4}$ " PITCH REF: 110046) Ensure chains are clean, correctly tensioned and regularly oiled. Suspect chains or drive sprockets should be replaced. **ALWAYS KEEP CHAIN COVER GUARD IN PLACE.**

Variable speed drive:- Lubricate as indicated on manufacturers instruction plates fitted to this unit.

FOUNDATION

This unit may remain free standing, though we would recommend that fixing to the floor after levelling be undertaken.

CONVEYOR BELT

During the working life of this unit it may be required to replace the conveyor belt completely. In such cases we can supply a suitable length of belting complete with fasteners. In such a case the following steps may be found helpful when fitting the fastener.

- (1) The belt supplied will be slightly longer and therefore will require square-cutting to the length required.
- (2) Assemble the fastener halves and insert the pivot rod checking that the complete fitting is the correct length for the width of the belt.
- (3) Bend one end of pivot rod to retain in place.
- (4) ~~Place fastener onto one end of the belt ensuring that the unbroken face of the fastener is positioned to the underside of the belt.~~
- (5) Place the belt on a wood block then position the copper rivet strips so that one rivet enters each hole on the fastener.
- (6) Gently and evenly tap the rivets down across the whole width of the belt until the rivet heads are nearly down to the plastic holder strip. Then turn the belt over and check that each rivet will pass through the lower hole on the fastener plate.
- (7) When sure that each rivet is correctly positioned turn belt over and back onto wood block and tap all rivets down and through thus breaking away the plastic holder strip.
- (8) Turn belt over and snip the point from each rivet to leave approximately 2 mm of copper rivet proud then flare over with hammer to produce a flush rivet head.

DO NOT BEND BACK (ie)

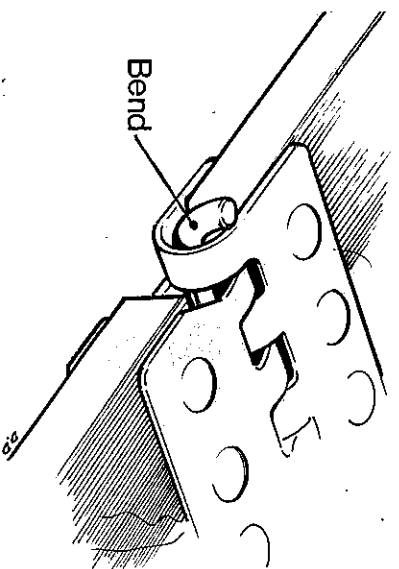
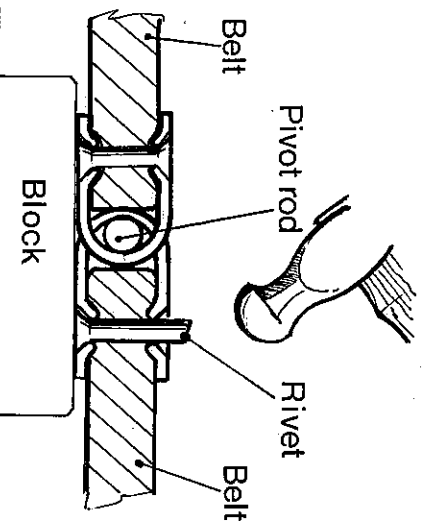

- (9) Place other end of belt into fastener and repeat previous operation ensuring that belt halves meet squarely and are in alignment.
- (10) To finish, rivet the remaining heads over remove pivot rod and turn belt over finishing as previously outlined.
- (11) Place belt onto conveyor, re-insert pivot rod and bend over remaining end to retain in place.
- (12) Re-tension belt by adjusting take-up units on idle roller end.

NOTE: - WHEN ORDERING SPARES QUOTE

"TABLE TYPE XMB"

**POWER
FEED
MACHINES
BCW/R/F
BCW/L/F.**

AIR OPERATED TOP STOCK CRAMP (USED ON STANDARD MACHINES ALSO)

This device is fitted to hold the stock flat down onto the machine to assist square cutting. It operates in sequence with the stop and saw and will clamp down as soon as the stock makes contact with the stop trigger just prior to the saw stroke and will immediately release on completion of cut to enable through feed.

We recommend that the slide columns of the cramp be cleaned and oiled frequently.

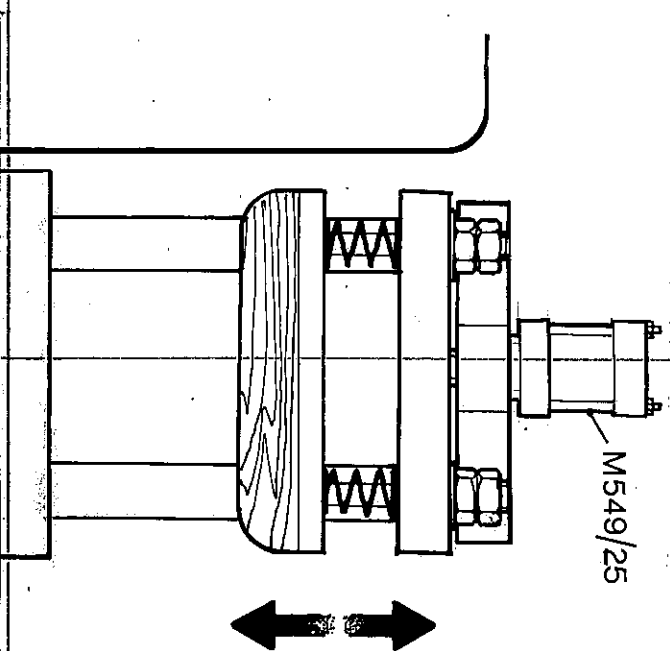

AIR OPERATED HELPERS & EJECTORS (USED ON STANDARD MACHINES ALSO)

A maximum of three ejectors can be fitted to any one machine. Their object is to provide a positive means of clearing cut lengths which may otherwise remain on the stop bar or between two stops thus causing an obstruction to through feeding. They work in sequence with the saw and will eject any pieces onto the fall away plate as soon as the cut has been completed.

