

Modifications are made to these books from time to time and it is important therefore that only the book sent with the machine should be used as a working manual

[ ]

PLEASE INSERT SERIAL NUMBER OF MACHINE

## INSTRUCTION MANUAL FOR

# BEM

## Heavy Duty Spindle Moulder

### SPECIFICATION.

|   |                                  |
|---|----------------------------------|
| Diameter of top piece. (Std) .....  | 30mm                             |
| Diameter of top piece. (Optional) .....   | 50mm, 35mm or 1½"                |
| Table Dimensions .....  | 1100mm x 900mm                   |
| Table Height .....  | 850mm                            |
| Vertical Movement of Spindle .....  | 210mm                            |
| Speed of Spindle. (Std) .....   | 3000, 4500, 6000, 7200rpm        |
| Speed of Spindle. (Extra) .....   | 3000, 4500, 6000, 7200, 10000rpm |
| Motor Output. (Std) .....   | 5HP                              |
| Motor Output. (Optional) .....  | 7½HP or 10HP                     |
| Max. dia of Tooling Accommodated under table .....  | 420mm                            |
| Five Circular Table Rings giving openings of: .....   | 80, 150, 190, 260, 340 and 450mm |
| Solid One piece Cast Iron Frame. Electrically Interlocked Foot Brake. Electrically Interlocked Control Lever. } | - All as Std.                    |

# Heavy Duty Spindle Moulder Type BEM

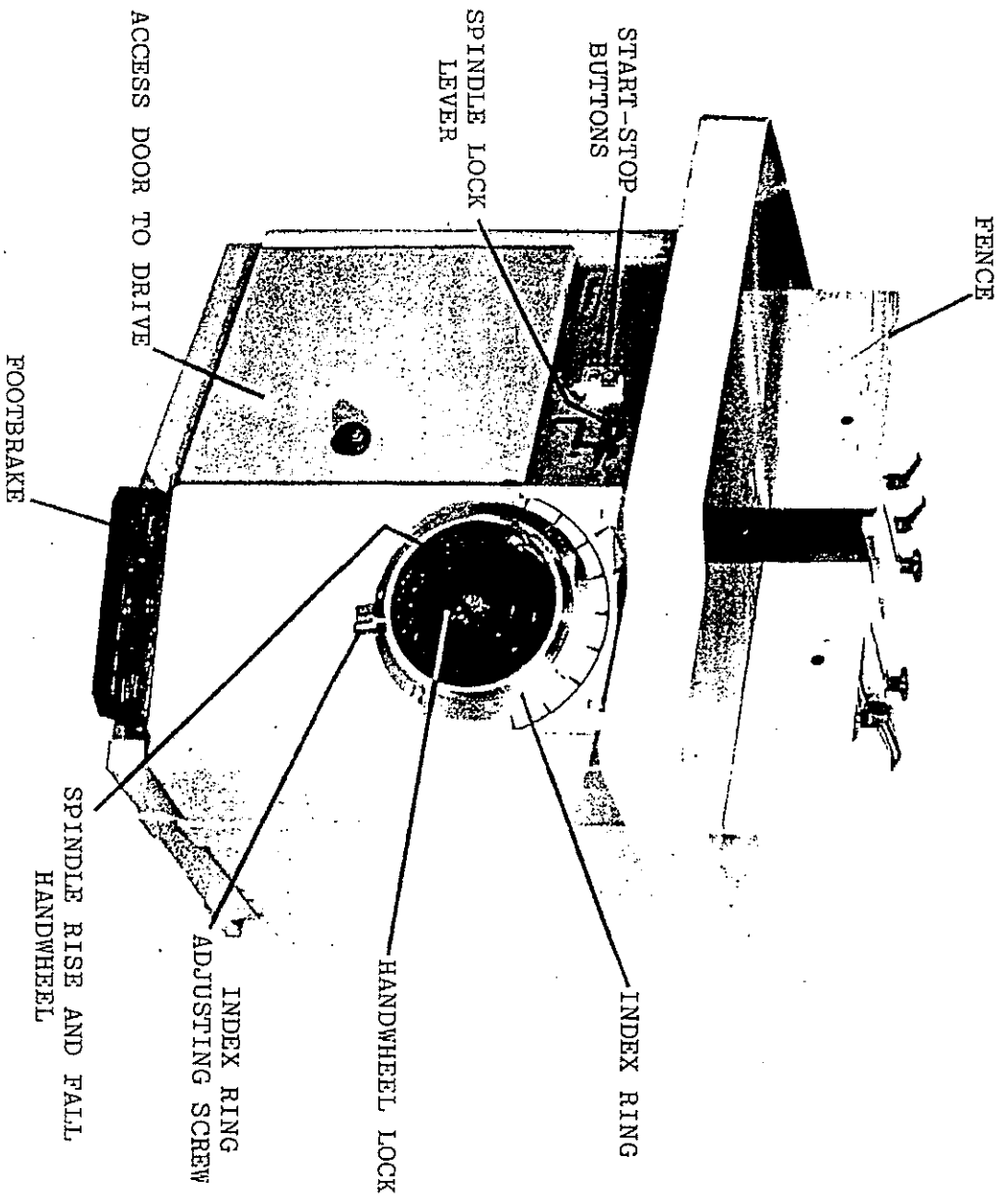

## INDEX

|  |            |
|--|------------|
| SPECIFICATION.                               | PAGE 1     |
| SAFETY INSTRUCTIONS.                         | PAGE 4 & 5 |
| SLINGING                                     | PAGE 6     |
| INSTALLATION                                 | PAGE 6     |
| FOUNDATION.                                  | PAGE 6     |
| WIRING DETAILS.                              | PAGE 6     |
| LUBRICATION.                                 | PAGE 6     |
| SPINDLE SPEED CHANGE AND BELT TENSION.       | PAGE 9     |
| RAISE AND LOWER OF SPINDLE.                  | PAGE 9     |
| INDEX RING ADJUSTMENT.                       | PAGE 9     |
| SPINDLE FOOT BRAKE.                          | PAGE 9     |
| SPINDLE LOCK.                                | PAGE 9     |
| WORK SPINDLE INSTALLATION.                   | PAGE 10    |
| FENCE ADJUSTMENT.                            | PAGE 10    |
| SHAW GUARD (EXTRA).                          | PAGE 13    |
| SAFETY GUARD AND RING FENCE (EXTRA).         | PAGE 13    |
| ISOLATOR SWITCH                              | PAGE 13    |
| GENERAL HINTS.                               | PAGE 13    |
| FRAMING ON SQUARE BLOCK.                     | PAGE 14    |
| SHAPED PANEL ON SLOTTED COLLARS.             | PAGE 14    |
| CIRCULAR CUTTERBLOCK WORK.                   | PAGE 14    |
| INSTRUCTIONS FOR REGRINDING PROFILE CUTTERS. | PAGE 16    |
| <b>Machine parts index</b>                   |            |
| MAIN FRAME ASSEMBLY.                         | PAGE 18    |
| MAIN SPINDLE ASSEMBLY                        | PAGE 20    |
| WORK SPINDLE ASSEMBLY.                       | PAGE 22    |
| RISE AND FALL HANDWHEEL ASSEMBLY.            | PAGE 24    |
| MOTOR MOUNTING ASSEMBLY.                     | PAGE 26    |
| BELT TENSION AND SPINDLE LOCK ASSEMBLY.      | PAGE 28    |
| BRAKE ASSEMBLY.                              | PAGE 30    |
| FENCE ASSEMBLY                               | PAGE 32    |
| TABLE RING AND CAM LOCK ASSEMBLY.            | PAGE 34    |

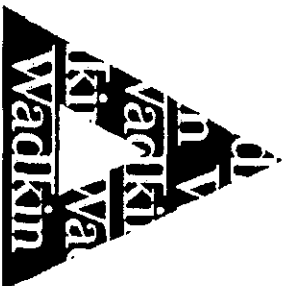

## HEALTH & SAFETY

### SAFETY OF WOODWORKING MACHINES

Woodworking machines can be dangerous if improperly used. The wide range of work of which they are capable, requires adequate safeguarding arrangements against possible hazards.

Many injuries to machinists are caused by carelessness or failure to use the guards provided or to adjust them correctly.

WADKIN LTD., supply machinery designed for maximum safety which they believe, as a result of thorough testing, minimizes the risks inevitable in their use. It is the user's responsibility to see that the following rules are complied with to ensure safety at work:

1. The operation of the machine should conform to the requirements of the Woodworking Machines Regulations 1974. All guards should be used and adjusted correctly.
2. Safe methods of working only should be adopted as given in the Health and Safety Work Booklet No.41, "Safety in the Use of Woodworking Machines", (obtainable from Her Majesty's Stationery Office) and as advised by Wadkin Ltd.
3. Only personnel trained in the safe use of a machine should operate it.
4. Before making adjustments or clearing chips, etc., the machine should be stopped and all movement should have ceased.
5. All tools and cutters must be securely fixed and the speed selected must be appropriate for the tooling.

*SAFETY IS OUR WATCHWORD BUT THE USER MUST COMPLY WITH THE ABOVE RULES IN HIS OWN INTEREST. WE WOULD BE PLEASED TO ADVISE ON THE SAFE USE OF OUR PRODUCTS.*

## Safety

CAREFULLY READ INSTRUCTION MANUAL WITH PARTICULAR REFERENCE TO THE FOLLOWING INSTRUCTIONS:-

1. SLINGING, i.e. SAFE LIFTING LIMITS FOR SLINGS ETC.
2. INSTALLATION AND FOUNDATION, i.e. SAFE WORKING AREA OF MACHINE AND BOLT POSITIONS, ETC.
3. WIRING DETAILS, i.e. WIRING DIAGRAM AND INSTRUCTIONS FOR SAFE WIRING OF MACHINE.
4. MACHINE CONTROLS AND OPERATING INSTRUCTIONS.
5. SELECT CORRECT SPEED FOR CUTTER EQUIPMENT AND ENSURE CUTTERS ARE SECURELY LOCKED IN POSITION.
6. SET GUARDS CORRECTLY TO COVER CUTTER EQUIPMENT AS MUCH AS POSSIBLE.
7. NOTE START/STOP CONTROL POSITION AND ISOLATOR SWITCH POSITION (IF FITTED) BEFORE OPERATING MACHINE.
8. USE FEEDING DEVICES WHERE POSSIBLE.
9. REFER TO HEALTH AND SAFETY AT WORK BOOKLET No.41 (IN U.K.) FOR SAFETY IN THE USE OF WOODWORKING MACHINERY.

SLINGING.

Slings used to lift machine must be well within the safety limits for weight of machine.  
Machine net weights are as follows:-

1. Machine fitted with 5HP motor (Standard) - 556Kg.
2. Machine fitted with 7.5HP motor (Extra) - 566Kg.
3. Machine fitted with 10HP motor (Extra) - 582Kg.

NOTE:- Approx. gross weight of machine fitted with heaviest (10HP) motor in packing case, - 636Kg.

To sling machine, position sling under table overhang at left and right hand side of machine, ensuring slings do not foul isolator switch (if fitted as an extra).  
Slowly lift machine ensuring machine is not tilting at an angle and that sling is not slipping.

INSTALLATION.

Remove protective coating from bright parts by applying a cloth soaked in paraffin, turpentine or other solvent.  
Machine should be so placed that the traffic of men and materials to and from it fits smoothly into the general scheme of traffic.  
Machine should be so placed that it will not be necessary for the operator to stand in or near an aisle as to cause a hazard.  
The minimum clearance on each working side of machine should be at least 750mm greater than the length of the largest material worked on the machine.

FOUNDATION.

See FIG.1 for bolt positions and clearances required.  
Foundation bolts are not supplied with machine except by special order.

WIRING DETAILS.

The motor and control gear have been wired in before despatch. All that is required is to connect the power supply to the starter or isolator when fitted.

Points to note when connecting to power supply:-

1. Check that the voltage, phase and frequency correspond to those on the motor plate, also the correct coils and heaters are fitted to the starter.
2. It is important that the correct size of cable is used to give the correct voltage at the starter. Too light a cable will give a voltage drop at the starter and may damage the motor.
3. Check main line fuses are of correct capacity. See fuse list inside starter cover.  
If isolator is fitted, check fuse list inside isolator cover.
4. Connect the line leads to the appropriate terminals.  
See FIG.2 for 3 phase supply.
5. Check all connections are sound.
6. Check the rotation of the motor for the correct direction.  
If this is incorrect, reverse any two of the line lead connections for 3 phase supply.

LUBRICATION.

It is advisable to keep all bright parts covered with a thin film of oil to prevent rusting.

TYPE OF OIL RECOMMENDED.  
TYPE OF GREASE RECOMMENDED.

POWER EM 125.  
SHELL ALVANIA 3.

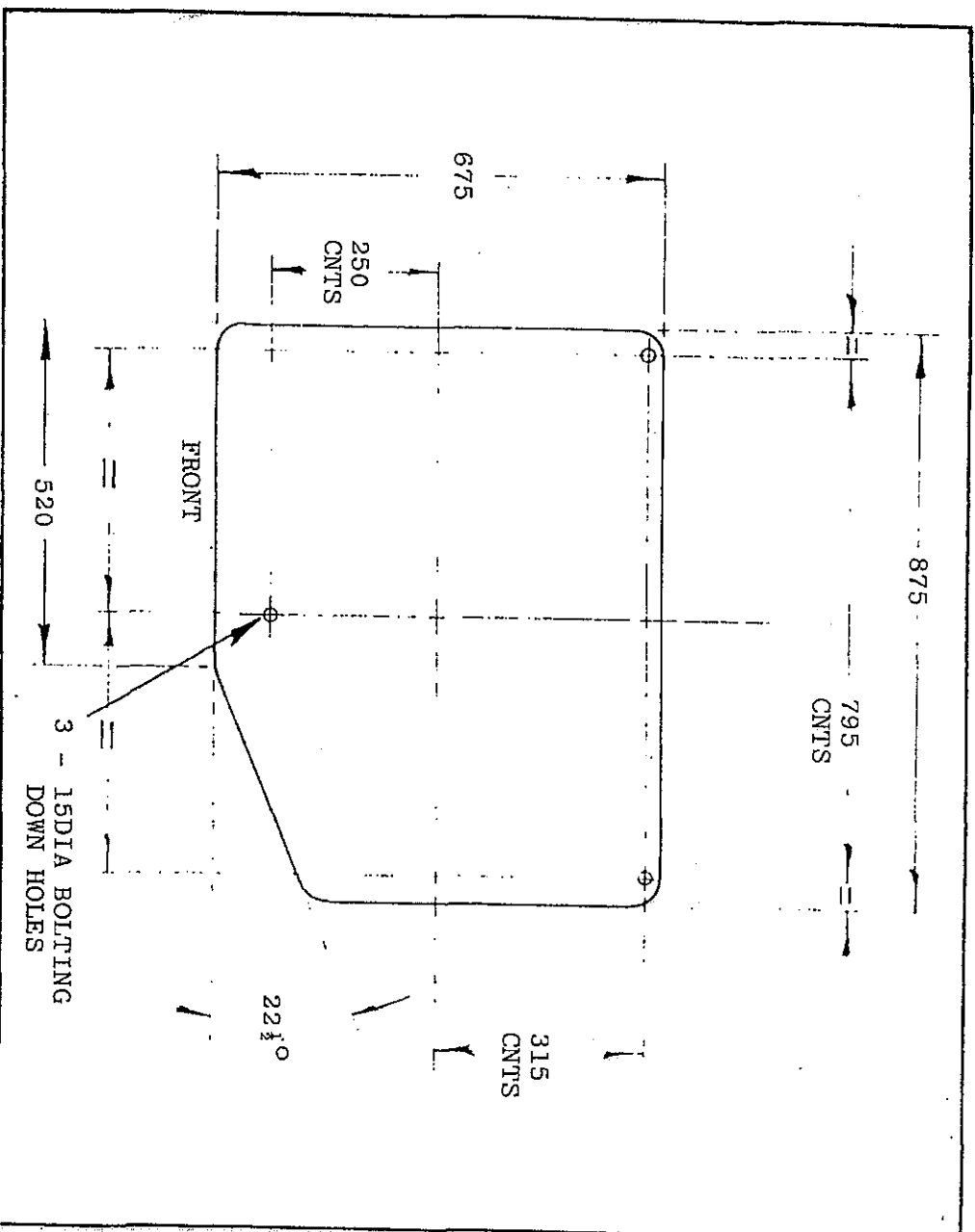
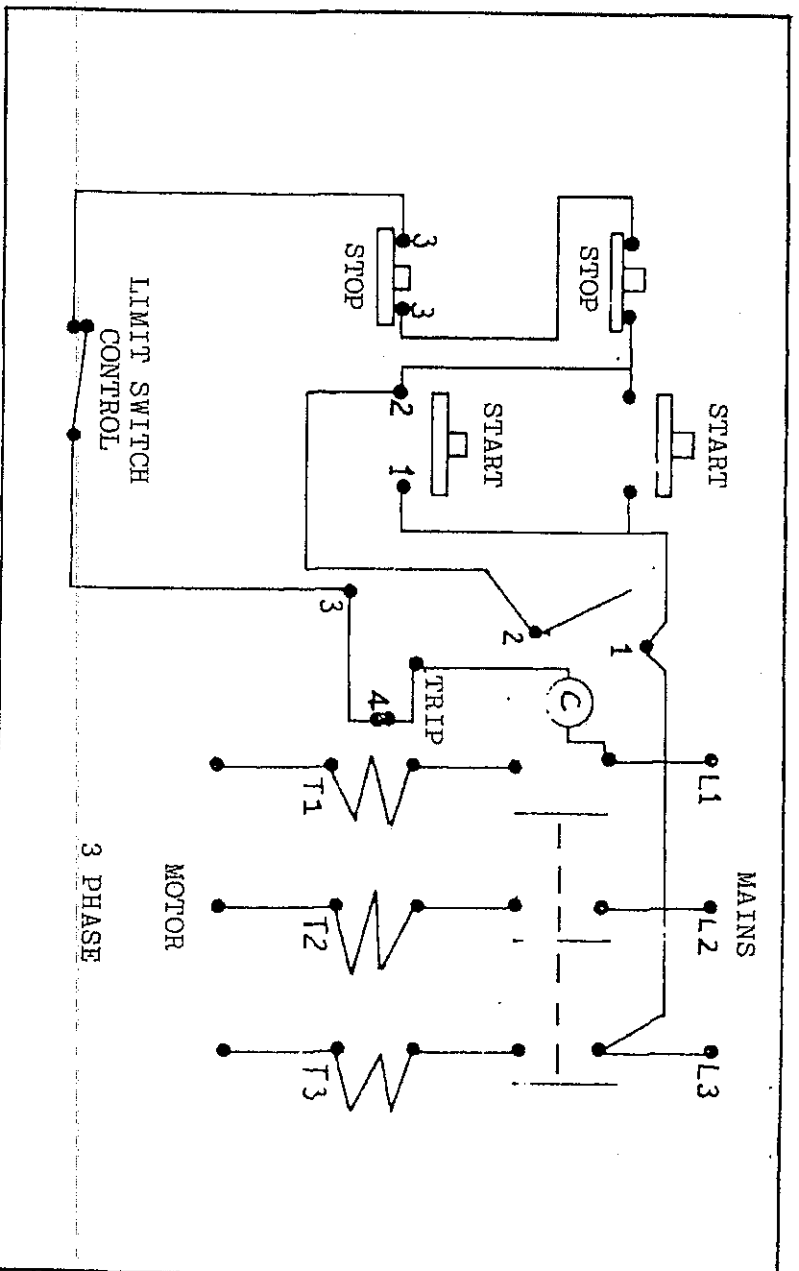

FIG. 1.



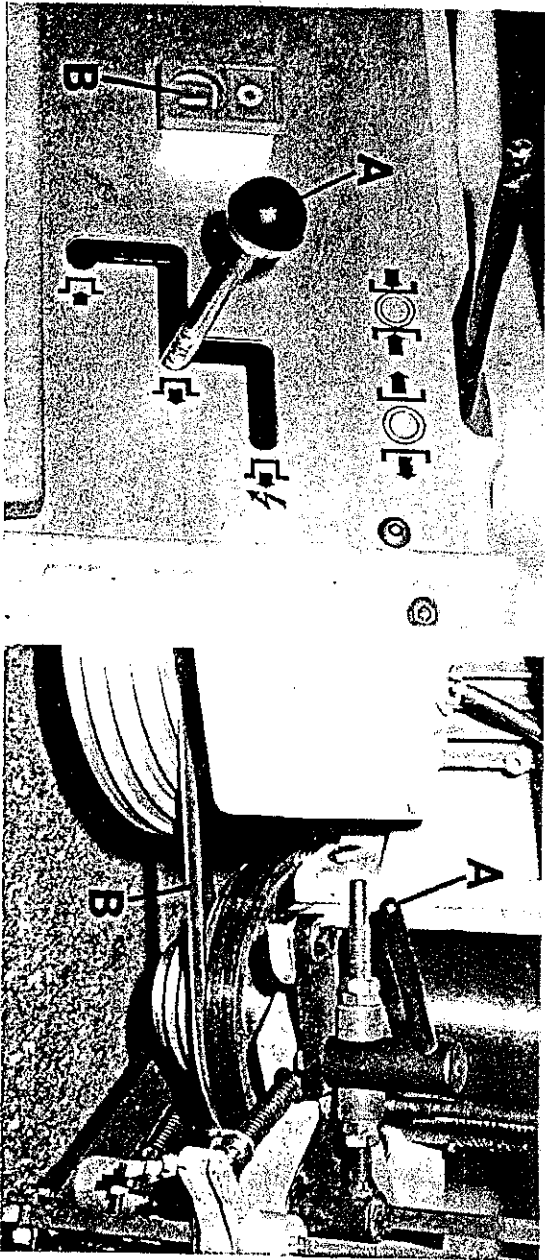

FIG. 3.

FIG. 4.

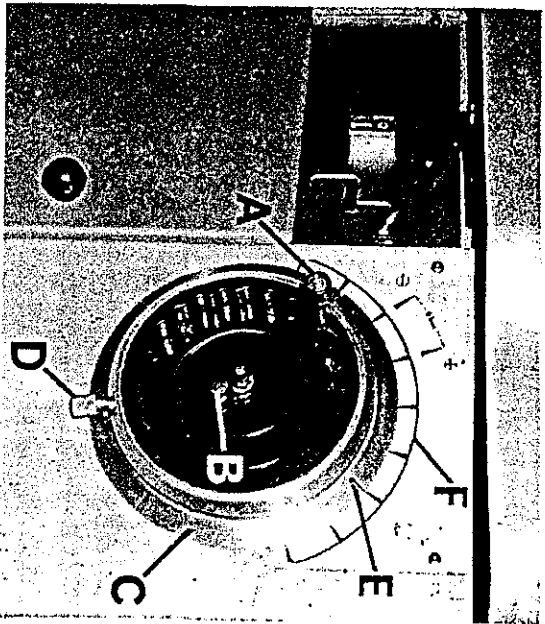
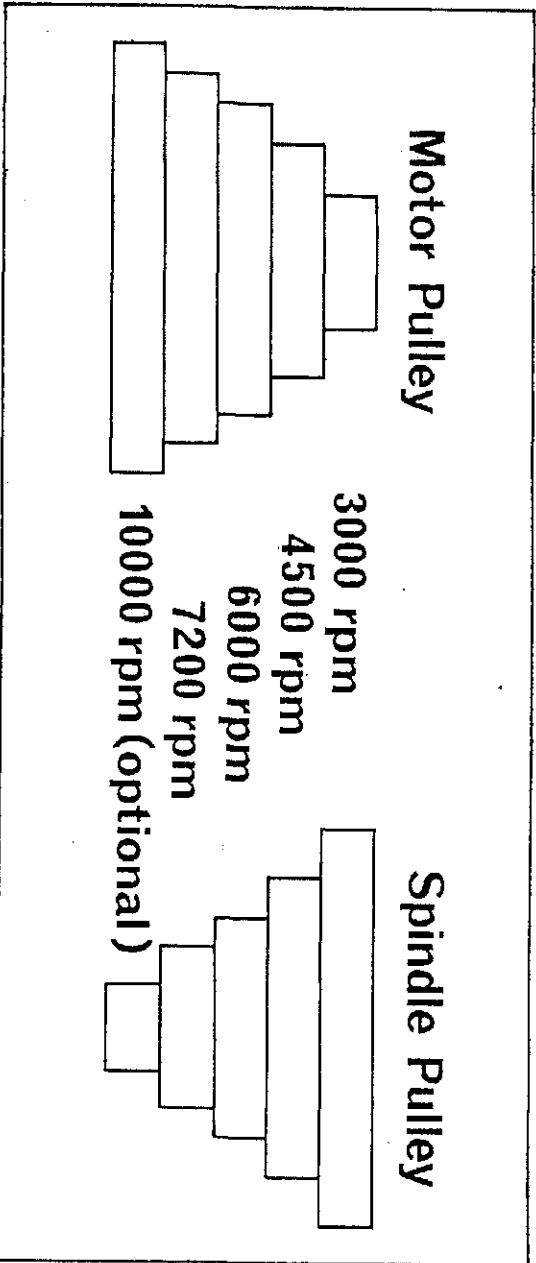

FIG. 6.

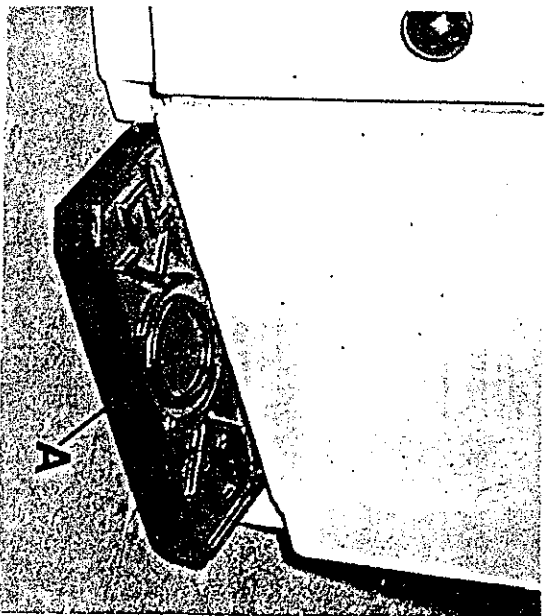

FIG. 7.

SPINDLE SPEED CHANGE AND BELT TENSION.

The spindle is fitted with a 4 speed drive facility as standard (5 - speed EXTRA).

To change spindle speed, proceed as follows:-

1. Isolate machine electrically.
2. Position lever "A", FIG.3, in spindle "free" position as shown.
3. Open door in base for access to drive arrangement.
4. Release belt tension by pulling lever "A", FIG.4.
5. Position drive belt "B" on pulleys for required spindle speed. SEE FIG.5, FOR SPINDLE PULLEY LAYOUT AND SPEEDS.
6. Re-tension belt by pushing lever "A", FIG.4, forward.
7. Close access door.

WARNING:

SELECT CORRECT SPEED FOR CUTTER EQUIPMENT (MAXIMUM RECOMMENDED SPEED IS STAMPED ON CUTTERBLOCK).

RAISE AND LOWER OF SPINDLE.

~~Spindle rise and fall is by handwheel "A" FIG.6, giving a maximum spindle travel of 210mm.~~

Spindle lock is by plastic handwheel "B".

Whilst the rise and fall movement of the spindle provides an immediate adjustment of cutter height, further adjustment outside this range can be affected by re-positioning collars on work spindle.

NOTE: 1 FULL TURN OF HANDWHEEL = 2mm VERTICAL ADJUSTMENT.

INDEX RING ADJUSTMENT.

An index ring "C", FIG.6, is fitted to the handwheel for micro adjustment of spindle rise and fall.  
To set index ring, proceed as follows:-

1. Loosen index ring locking screw "D" and position one of the four index ring marks "E" adjacent to a mark on scale "F", lock screw "D".
2. Loosen locking handwheel "B".
3. Turn handwheel "A" using mark on index ring against marks on scale for spindle micro adjustment rise or fall.  
NOTE: Moving handwheel index mark "E" between one scale mark and next = 0.1mm spindle rise or fall.
4. When required vertical spindle height is attained, tighten handwheel lock "B".

SPINDLE FOOT BRAKE.

Depression of foot brake "A", FIG.7, operates a limit switch which cuts electrical supply to spindle motor whilst braking the spindle to a stop.

NOTE: The motor can only be re-started by depressing start button "B", FIG.3.

SPINDLE LOCK.

To lock spindle, proceed as follows:-

1. Stop spindle by spindle foot brake.
2. Move spindle lock lever "A", FIG.8, towards spindle lock position "B" and rotate spindle by hand until spindle lock engages.

NOTE: Spindle lock lever actuates an electrical limit switch and machine cannot be re-started until spindle lock is disengaged.

SAFETY WARNING:- DO NOT ENGAGE SPINDLE LOCK UNTIL SPINDLE HAS STOPPED REVOLVING.

WORK SPINDLE INSTALLATION.

The 5 removable table rings give 5 table openings of 450, 340, 260, 190, 150 and 80mm dia. (17 $\frac{1}{2}$ ", 13  $\frac{3}{8}$ ", 10 $\frac{1}{4}$ ", 7 $\frac{1}{2}$ ", 6", 3  $\frac{1}{8}$ ").

Select required table opening before proceeding to fit work spindle. To insert work spindle, follow undermentioned procedure. Locate work spindle "A", FIG.9, into main spindle through table opening taking care to ensure that work spindle and main spindle seatings are completely free from all burrs/dirt and rust. Smear a thin film of oil on work spindle seatings before inserting then align peg in work spindle with slot in main spindle and press spindle onto seating.

Lock work spindle, SEE "SPINDLE LOCK", then securely tighten spindle locknut "B", FIG.9, on main spindle, firmly locking the work spindle in position.

**IMPORTANT:-** Always ensure at all times that the work spindle is securely held by the spindle locknut before starting machine.

FENCE ADJUSTMENT.

Each fence plate can be independently adjusted by loosening the required locking handle "A", FIG.10, and turning the appropriate handwheel "B". When set re-lock handle "A".

For lengthwise movement of fence plates, loosen locknut "C", position fence plate as required then tighten locknut "C".

**NOTE:** The fence plates must be locked in all positions when machine is in use.

A safety guard "D" is fitted to fence and is adjustable to protect the operator from the rotating cutters. To adjust guard loosen the 2 handwheels "E", position guard to cover cutters as much as possible then re-lock handwheels "E". The complete fence unit can be set in any position throughout 360° (example position shown in FIG.12). This facility enables the operator to feed long lengths of timber along machine and clear any obstructions which may be in line of feed, i.e. stack of previously machined timber, walls or other machines etc.

To set fence unit, move lever "A", FIG.11, to right (i.e. fence free position), swing fence around to required position then push lever "A" to left (i.e. fence locked position).

SAFETY NOTE.

If machine is used for more than 6 hours in every week, then under 1974 Woodworking Machine Regulations, machine should be connected to dust exhaust system. Should machine be used for less than above period then we suggest that a guard be produced from drawing (see page 37), and secured to rear of fence by M12 x 25 long hexagon head bolt.

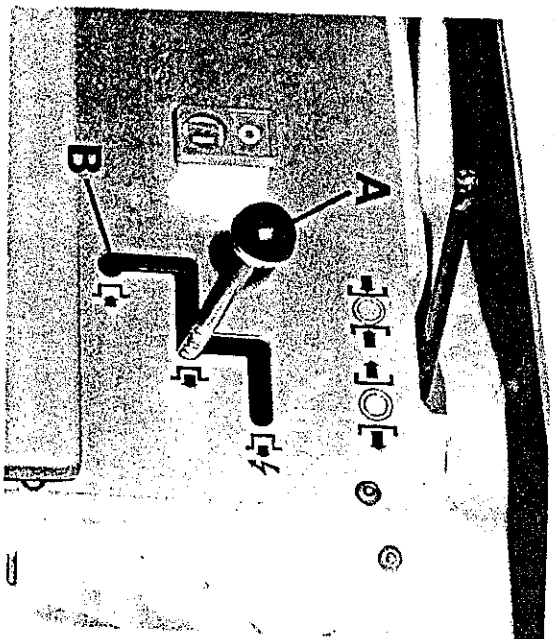

FIG. 8.

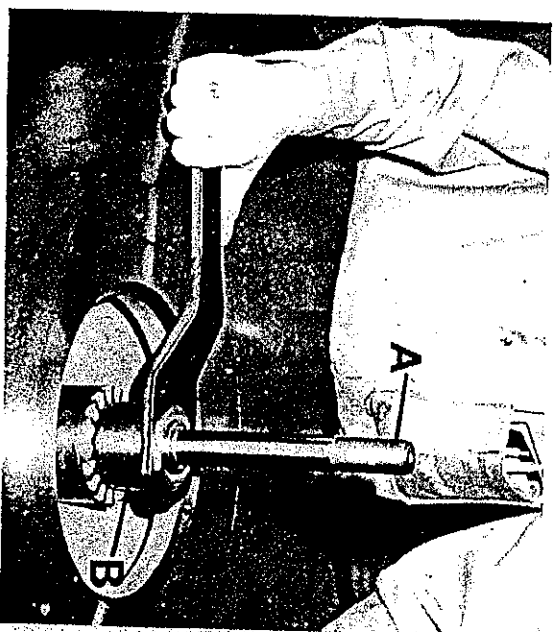

FIG. 9.

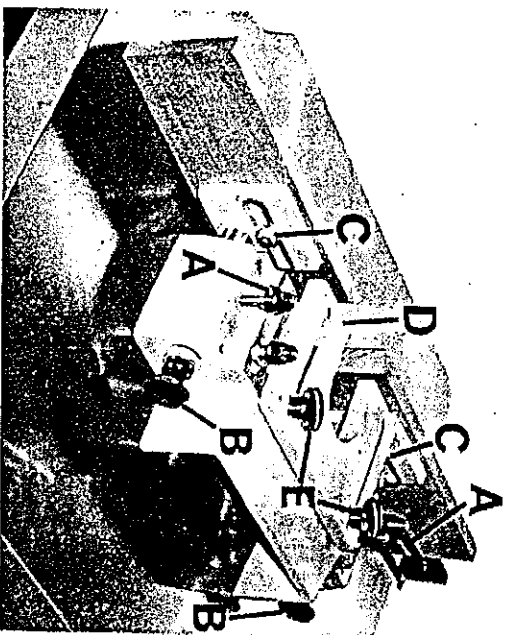

FIG. 10.

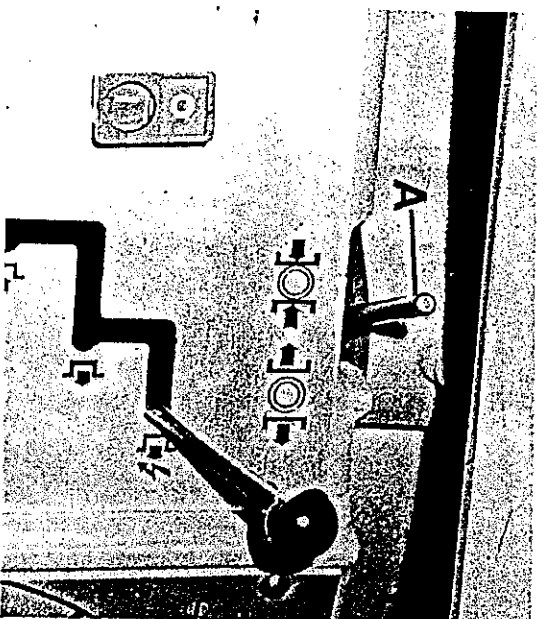

FIG. 11.

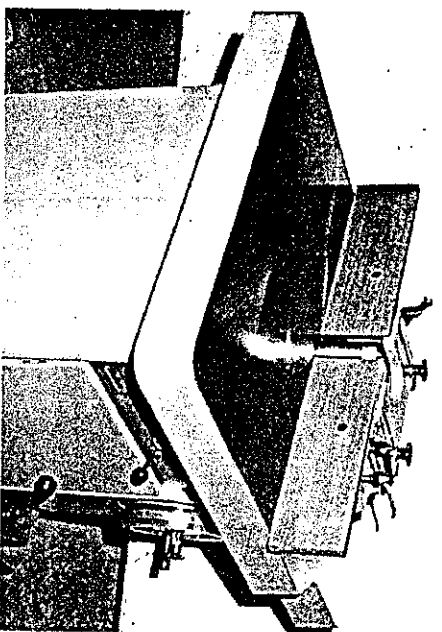

FIG. 12.

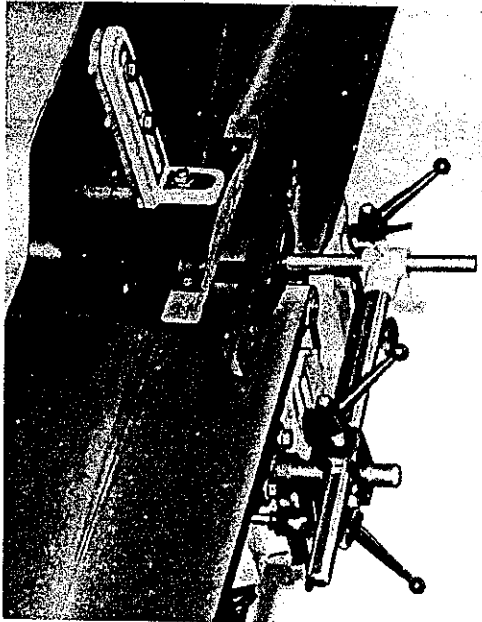

FIG. 13.

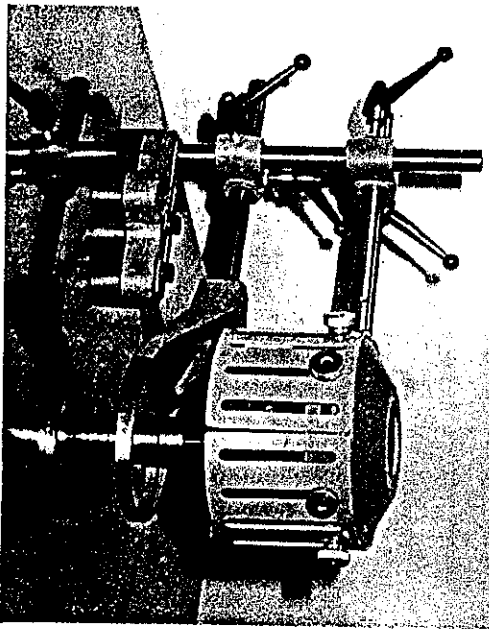

FIG. 14.

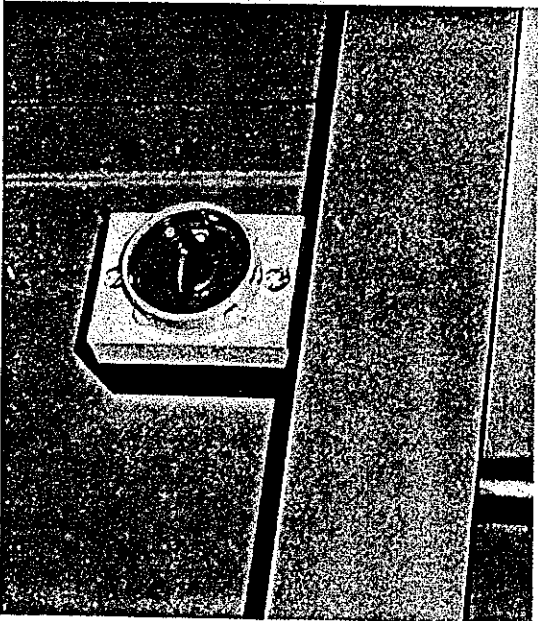

FIG. 15.

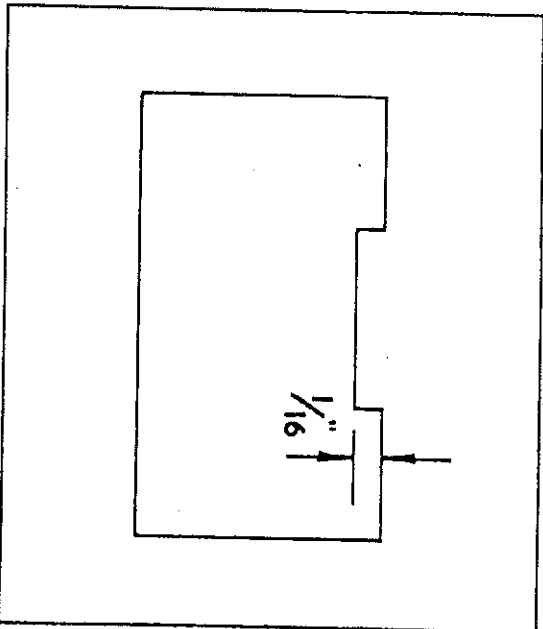

FIG. 16.

SHAW GUARD (EXTRA).

A shaw guard can be fitted as shown in FIG.13. This guard provides top and side pressure to timber ensuring safety in operation for use with standard fence.

SAFETY GUARD AND RING FENCE (EXTRA).

A safety guard and ring fence can be fitted as shown in FIG.14. This guard has adjustable flaps which completely cover the cutter equipment and is used in conjunction with ring fence which is for use on all types of curved work.

ISOLATOR SWITCH (EXTRA).

An electrical isolator switch, FIG.15, can be supplied with machine as an optional extra.

GENERAL HINTS

1. Always select the correct speed for the cutter equipment being used. Wadkin/Bursgreen cutterblocks are normally stamped with the maximum permissible speed, but this may need to be reduced dependent on shape and general condition of cutters being used.
2. Use sharp cutters which should be reasonably well balanced.
3. Ensure the cutters are tight on the blocks before starting machine. Use spanners provided and never fit a piece of piping to obtain greater leverage. This will strain the nuts and bolts and ultimately make them unsafe.
4. Never pack the cutters with sandpaper. This is most dangerous as the grit collapses when the cutter is working, and the cutter works loose. For packing use one thickness only of brown paper.
5. Keep nuts and bolts clean and keep oil on the threads.
6. Never run the cutter equipment at higher than the recommended speed.
7. Always use the guards available to ensure maximum protection.
8. Make good robust jigs and ensure that the parts are located securely on the jig.
9. Always isolate the machine electrically when changing cutter equipment or performing maintenance, etc..
10. Always notch cutters for french spindles as shown in FIG.16. for the spindle locking bolt to locate the cutter.

FRAMING ON SQUARE BLOCK FIG. 17.

Equipment required:- 30mm diameter loose screwed spindle, square cutterblock, three pair of cutters, straight fence and shaw guard. The cutters will have to be shaped to suit the moulded portion, allowing for angle by using the moulder's rule. Each pair of cutters must be balanced to prevent vibration, then accurately set up on the square block, so that all are cutting.

The cutterblock is then mounted on the spindle, fences set correctly in line, top and side spring pressures set to hold work firmly to the fences.

Spindle speed:- 4,500rpm

Note:- Cutters are always used in pairs to maintain balance.

SHAPED PANEL ON SLOTTED COLLARS FIG. 18.

Equipment required:- 1½"(30mm) diameter loose screwed spindle one pair of slotted collars (one being the ball bearing type) one pair nosing cutters and safety guard with flaps. The cutters are set up in the collars keeping minimum track in line with the bottom ball bearing slotted collar. The collars are mounted on a 1½"(30mm) diameter loose top piece. The work piece is held by spikes to master former which is below the work.

The safety guard is set to cover the cutters and top piece. The former is passed across the guide. The cutters are completely shielded from the operator's hand by the work.

Spindle speed:- 7,200rpm

CIRCULAR CUTTERBLOCK WORK FIG. 19.

Equipment required:- 30mm diameter loose top piece 3"(76mm) deep circular cutterblock, ring fence and safety guard with flaps.

The cutterblock is mounted on the 1½"(30mm) diameter loose top piece and set so that the cuttertrack is in line with the ring fence as shown in FIG. 19. The guard is then set to cover up block and top piece leaving only sufficient room for work to pass underneath. Work is to be mounted on a shaped fixture which is held up to the ring fence. Contact must always be at the same point on the ring fence to ensure even depth of cut. This is essential due to the shape of the ring.

The circularblock gives a good smooth cut and finish to work.

Spindle speed:- 7,200rpm

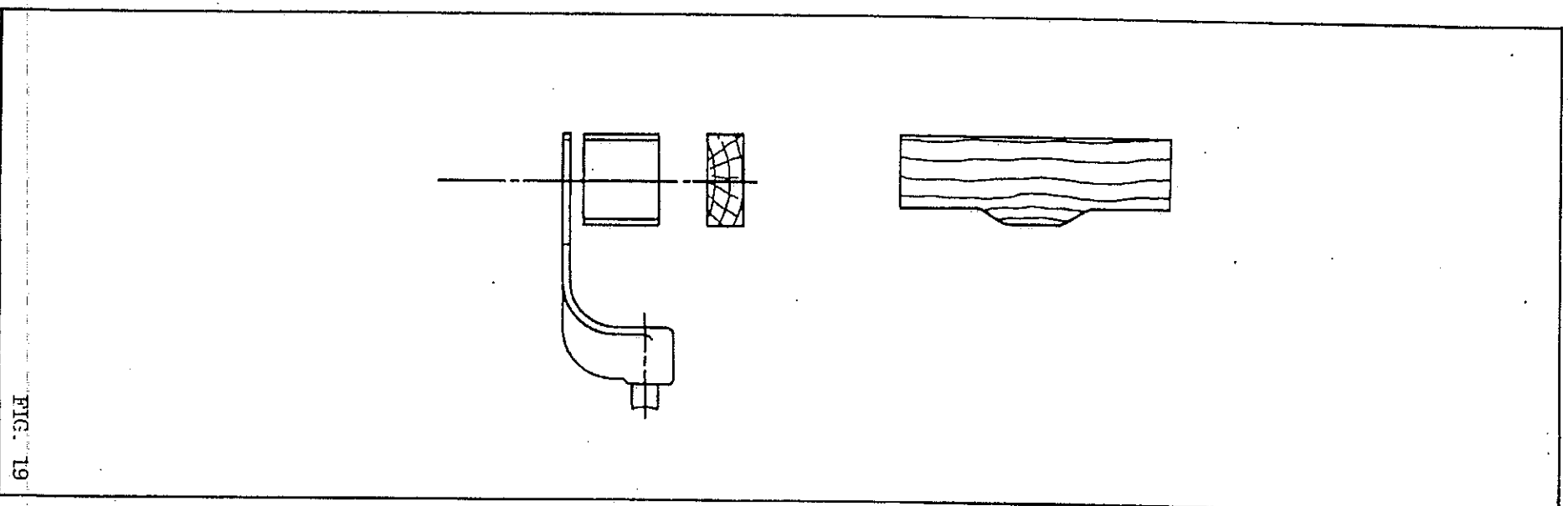
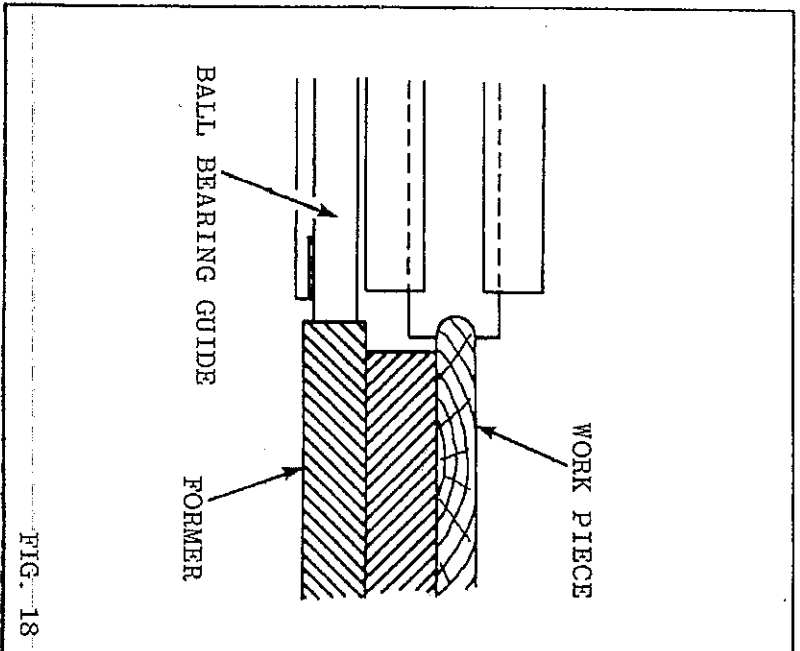
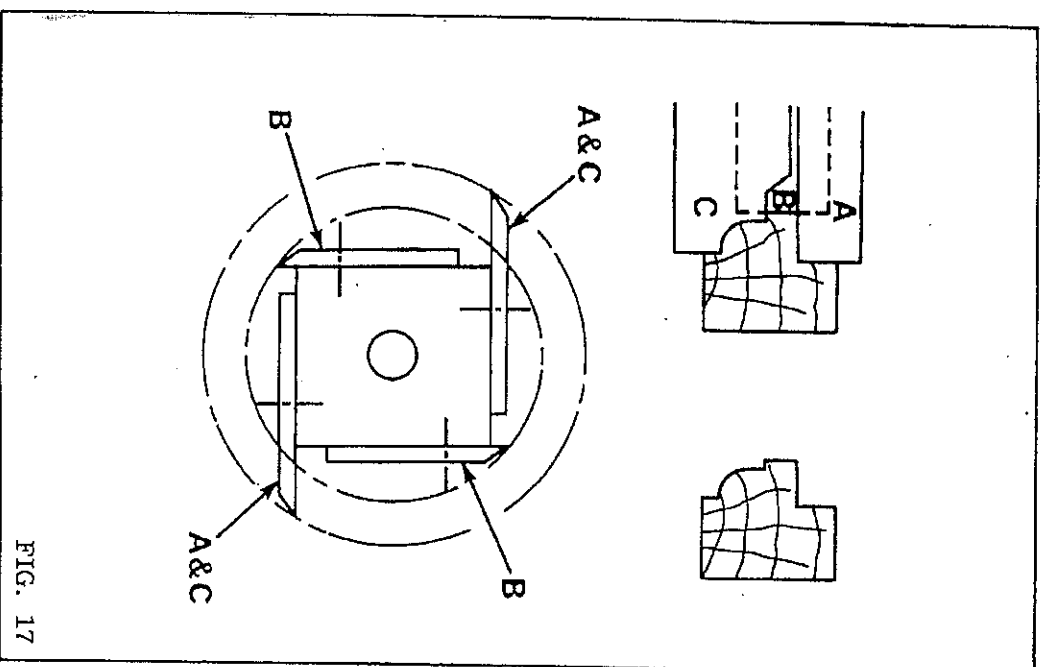

## B Instructions For Regrinding Profile Cutters

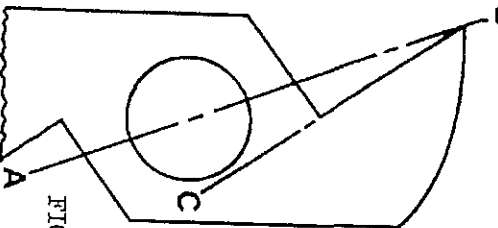
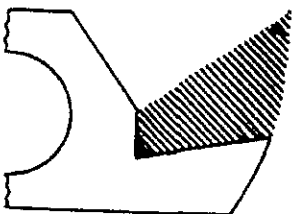
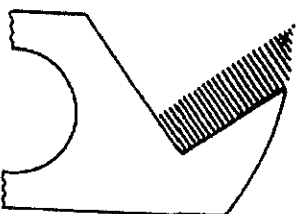

FIG. 1

Correct  
FIG. 2Incorrect  
FIG. 3

There are two methods of grinding these cutters:

1. With precision tool grinder.  
This method involves grinding the cutter on an arbor between centres. The machine should be set to grind the face of the cutter so that angle ABC, in Fig. 1 is the same after grinding as it was originally.
2. With hand or bench grinder

Before regrinding the cutters by this method, ensure that the check chart supplied with the cutters is to hand. To check the angle of the cutters, place the new ground face, i.e. line BC, in Fig.1, against that of the check chart and when the angle is correct, the bore of the cutter should correspond to that of the check chart. This ensures that the correct angle is maintained at all times.

### NOTES

1. A slight variation in the angle ABC, in Fig. 1 on opposite wings of the cutter is not too important, but for the best results, avoid having the point "B" in Fig. 1 or its opposite on a different radius. This would cause one cutting edge to do all the cutting and would make the cutter out of balance and cause vibration.
2. When making single cuts with more than one cutter in the set up, always STAGGER the cutting edges rather than line them up. Doing this improves the quality of the work and reduces vibration and chatter. Staggered cutters require less power than "in line" cutters.
3. Cutters must always be ground in the root of the tooth, as shown in Fig.2 never as in Fig.3. Otherwise the cutters will drag or fail to cut the complete shape. Failure in observing this point results in weakening the tooth form and shortening the usable life of the cutter.

### CAUTION

We do not recommend these cutters to be used on anything but short runs of plywood or resin bonded wood substitutes, because resinous glues used in making plywood etc. are extremely hard and abrasive. This causes the cutters to overheat and soften if not of the Tungsten Carbide Tipped variety. Write for prices of special tipped cutters for such materials.

# **Machine Parts List**

**IMPORTANT.**

**WHEN ORDERING REPLACEMENT PARTS, PLEASE QUOTE PART NUMBER AND SERIAL NUMBER OF MACHINE.**

MAIN FRAME ASSEMBLY.

| <u>Ref No.</u> | <u>Part No.</u> | <u>No. Off.</u> | <u>Description.</u>                    |
|----------------|-----------------|-----------------|--|
| 1.             | 1057/455        | 1               | Small table ring.                      |
| 2.             | 1057/454        | 1               | Medium table ring.                     |
| 3.             | 1057/453        | 1               | Large table ring.                      |
| 4.             | EM/79           | 1               | Front plate for starter.               |
| 5.             | DTD-KD          | 1               | Klockner Moeller, stop-start switch.   |
| 6.             |                 | 4               | M8 x 20 long socket head button screw. |
| 7.             |                 | 4               | M5 x 15 long socket head button screw. |
| 8.             |                 | 2               | Rubber door buffer.                    |
| 9.             | EM/108          |                 | Cam lock.                              |
| 10.            | EM/49           | 1               | Belt change door.                      |
| 11.            | 1546ADS         | 1               | MEM starter.                           |
| 12.            |                 | 4               | M8 x 20 long socket head button screw. |
| 13.            | 1057/460        | 1               | Outer table ring.                      |
| 14.            | EM/4            | 1               | 450mm dia. table ring.                 |
| 15.            | EM/1            | 1               | Table.                                 |
| 16.            | EM/83           | 1               | Front plate for handwheel.             |
| 17.            | EM/2            | 1               | Base                                   |
|                | EM/56           | 1               | Turret stop base (EXTRA).              |

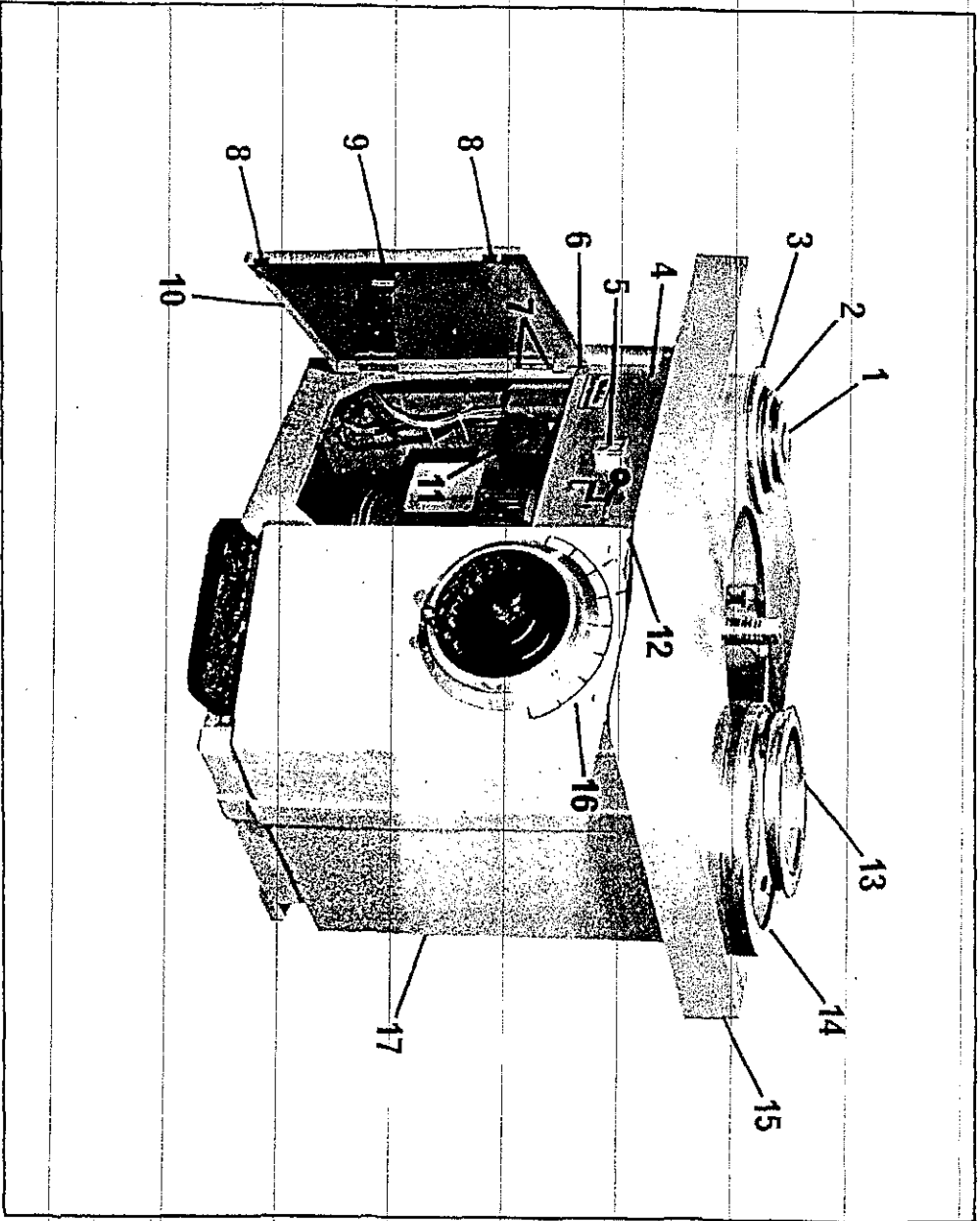

MAIN FRAME ASSEMBLY

MAIN SPINDLE ASSEMBLY

| <u>Ref No.</u> | <u>Part No.</u> | <u>No. Off.</u> | <u>Description.</u>                               |
|----------------|-----------------|-----------------|---|
| 20             |                 | 4               | 12mm spring washer.                               |
| 21.            |                 | 4               | M12 x 35 long socket head capscrew.               |
| 22.            | D-1085/3        | 1               | Rise and fall housing.                            |
| 23.            |                 | 1               | 5mm dia x 20 long groverlok spring<br>dowel.      |
| 24.            |                 | 1               | Spindle rise and fall screw.                      |
| 25.            | B-1085/37       | 1               | Rise and fall nut.                                |
| 26.            | A-1085/141      | 1               | Spindle housing rise and fall stop<br>rod.        |
| 27.            | 51107 x         | 1               | Thrust race.                                      |
| 28.            |                 | 1               | M12 x 45 long socket head capscrew.               |
| 29.            |                 | 3               | M8 hexagon locknut.                               |
| 30.            |                 | 1               | 5mm dia x 15 long groverlok spring<br>dowel.      |
| 31.            | EM/103          | 1               | Spindle rise and fall screw thrust<br>plate.      |
| 32.            |                 | 3               | M6 locknut.                                       |
| 33.            |                 | 3               | M6 x 12 long socket head grubscrew.               |
| 34.            |                 | 3               | M8 x 25 long hexagon head bolt.                   |
| 35.            | 7000-080        | 1               | Internal circlip.                                 |
| 36.            | EM/11           | 1               | Rise and fall quill.                              |
| 37.            | EM/39           | 1               | Spindle adaptor nut.                              |
| 38.            | EM/53           | 1               | Dust cap.   |
| 39.            | EPL-58          | 3               | Thrust washer.                                    |
| 40.            | 6010-22         | 2               | Bearing.  |
| 41.            | EM/30           | 1               | Spindle bearing distance piece.                   |
| 42.            | EM/32           | 1               | Main spindle m/cs.79100 to 79111                  |
|                | EM/157          | 1               | m/cs.79112 to 81405                               |
|                | EM/227          | 1               | m/cs.81406 onwards                                |
| 43.            | EM/10           | 1               | Quill base plate.                                 |
| 44.            | 7000-068        | 2               | Internal circlip.                                 |
| 45.            | 6206-22         | 1               | Bearing.  |
| 46.            |                 | 4               | M8 x 45 long socket head capscrew.                |
| 47.            |                 | 1               | 8 x 8 x 55 long key.                              |
| 48.            | EM/525          | 1               | Spindle pulley (4 speed - 50 cycles)<br>Standard. |
|                | EM/526          | 1               | Spindle pulley (5 speed - 50 cycles)<br>Extra.    |
|                | EM/527          | 1               | Spindle pulley (5 speed - 60 cycles)<br>Extra.    |
| 49.            | 1026/285        | 1               | Washer for spindle pulley.                        |
| 50.            |                 | 1               | 10mm spring washer                                |
| 51.            |                 | 1               | M10 x 35 long socket head capscrew.               |
| 52.            |                 | 1               | 12mm spring washer.                               |

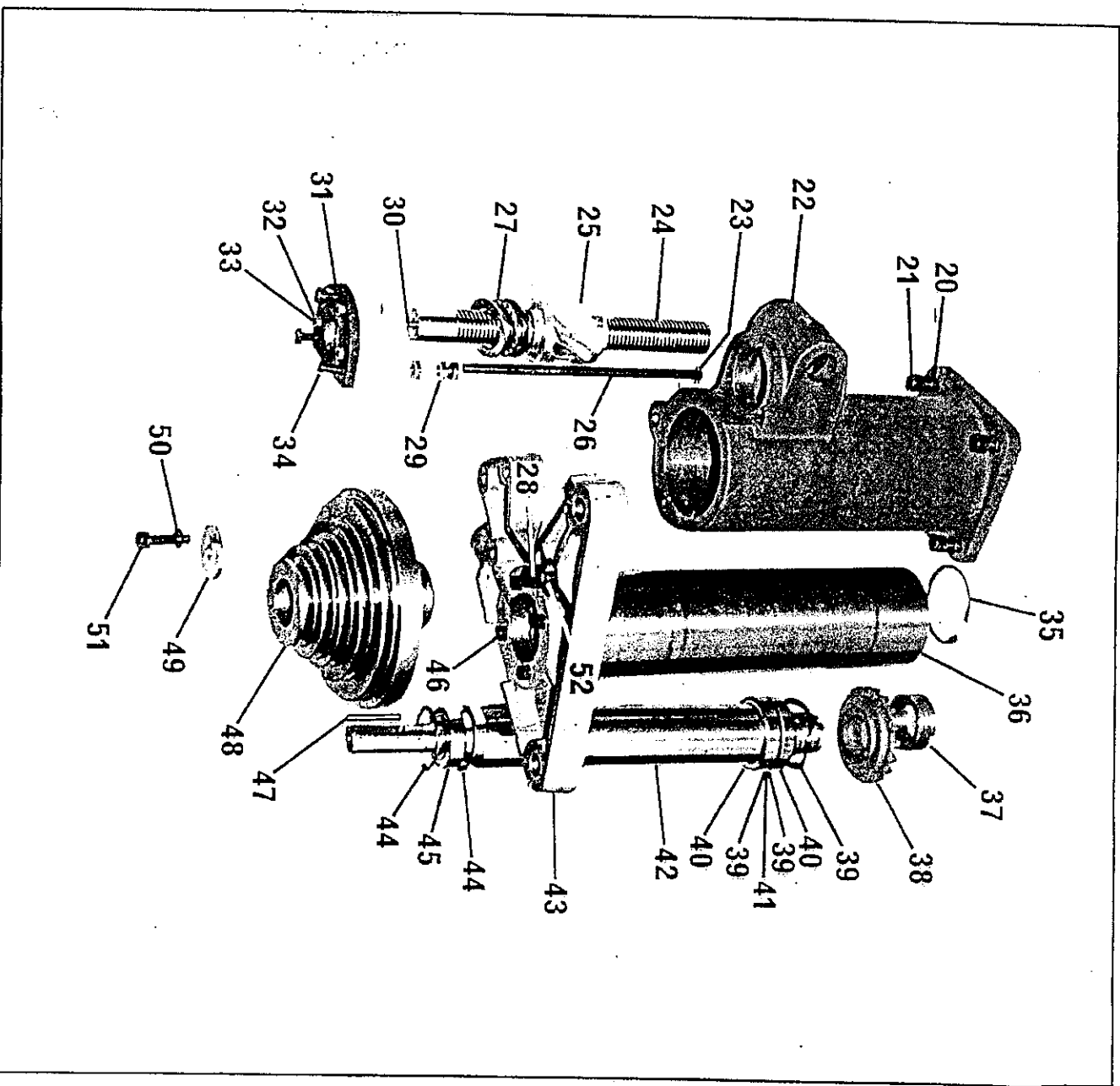

MAIN SPINDLE ASSEMBLY

WORK SPINDLE ASSEMBLY.

| <u>Ref No.</u> | <u>Part No.</u> | <u>No. Off.</u> | <u>Description.</u>       |
|----------------|-----------------|-----------------|---------------------------|
| 60             | 1057/31         | 1               | Work spindle nut.         |
| 61             | EM/38           | 1               | Main spindle nut.         |
| 62             | 1057/139        | 1 set.          | 30mm dia spacing collars. |
| 63             | 1057/88         | 1               | Work spindle, 30mm dia.   |

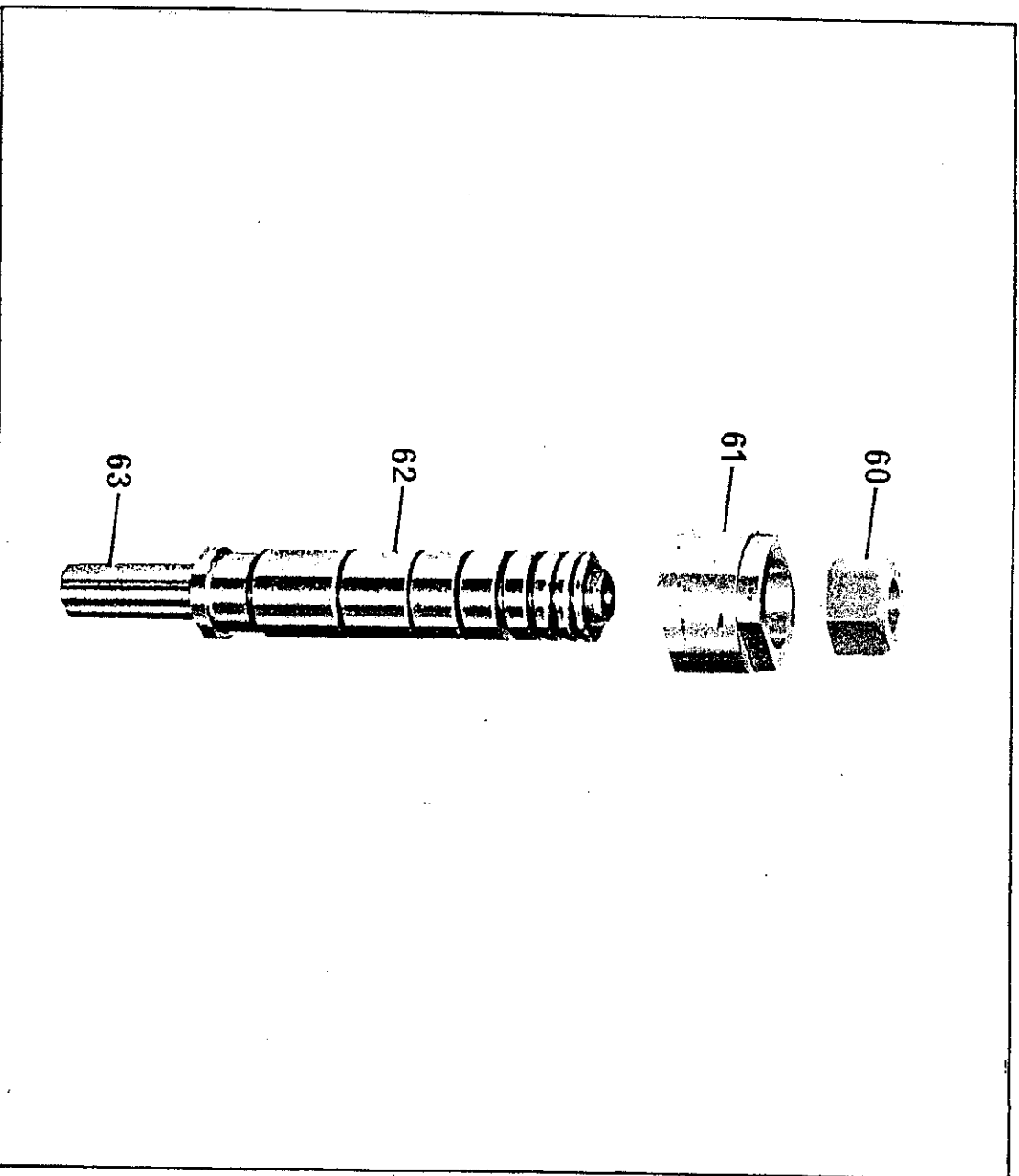

WORK SPINDLE ASSEMBLY

RISE AND FALL HANDWHEEL ASSEMBLY.

| <u>Ref. No.</u> | <u>Part No.</u> | <u>No. Off.</u> | <u>Description.</u>   |
|-----------------|-----------------|-----------------|---|
| 70              | EM/21           | 1               | Spindle rise and fall screw.                                |
| 71              | SKF-51104       | 2               | Thrust race.  |
| 72              | EM/5            | 1               | Handwheel bearing bracket.                                  |
| 73              | EM/106          | 2               | Washer for bearing bracket.                                 |
| 74              |                 | 2               | M8 x 25. long socket head button screw.                     |
| 75              |                 | 1               | 6 x 6 x 30 long key.  |
| 76              | EM/67           | 1               | Adjusting screw for handwheel.                              |
| 77              | EM/12           | 1               | Index ring.   |
| 78              | EM/6            | 1               | Rise and fall handwheel.                                    |
| 79              | EM/84           | 1               | Handwheel locking stud.                                     |
| 80              |                 | 1               | M10 plastic handwheel for rise and fall handwheel.          |
| 81              |                 | 1               | M12 domed nut.  |
| 82              |                 | 1               | M12 locknut.  |
| 83              |                 | 1               | 12mm washer.  |
| 84              | EM/69           | 3               | Index ring locking screw.                                   |
| 85              | 1026/381        | 1               | Pin for plastic handle.                                     |
| 86              |                 | 1               | 10mm plain bore plastic handle for rise and fall handwheel. |
| 87              | 7100/010        | 1               | External circlip.   |

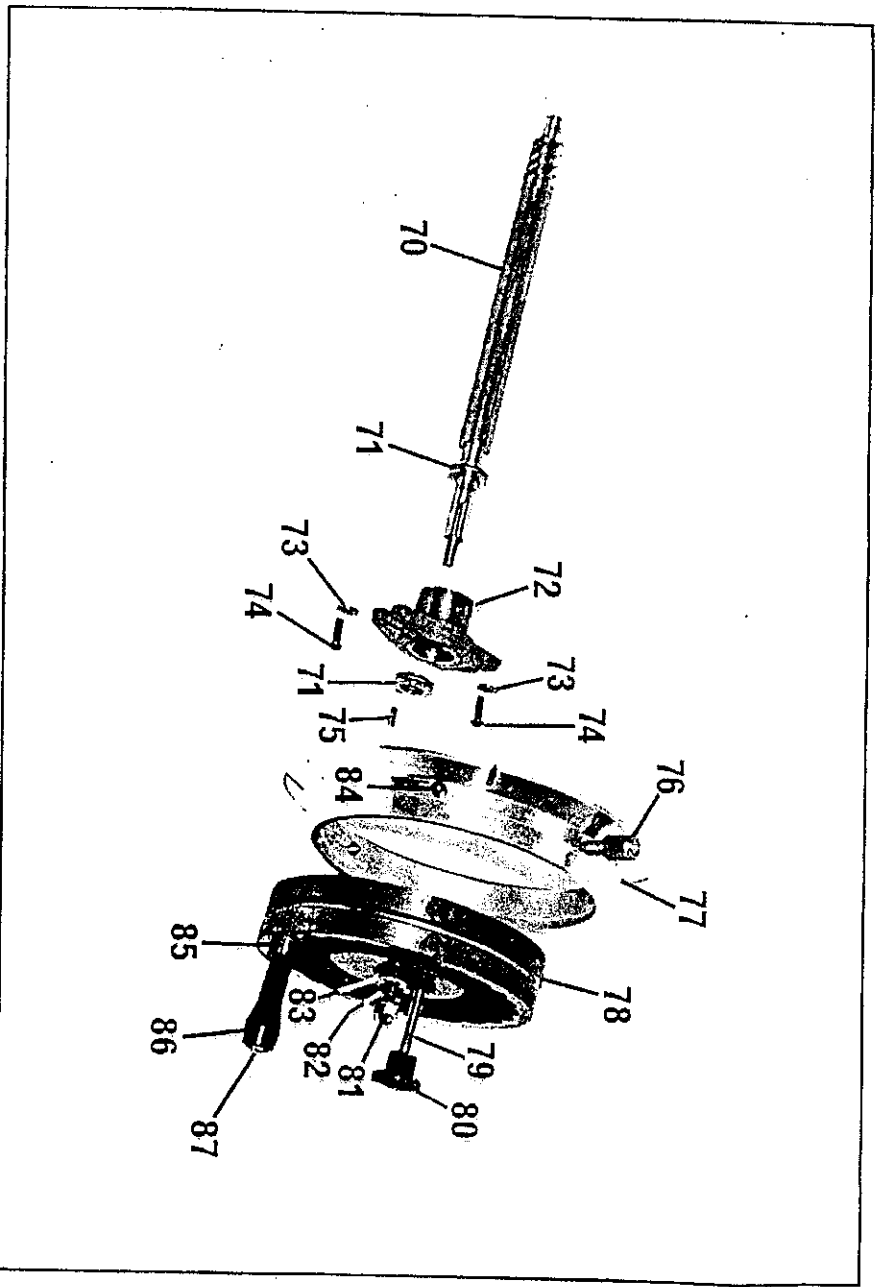

RISE AND FALL HANDWHEEL ASSEMBLY

MOTOR MOUNTING ASSEMBLY.

| <u>Ref. No.</u> | <u>Part No.</u> | <u>No. Off.</u> | <u>Description.</u>  |
|-----------------|-----------------|-----------------|--|
| 90              | 1085/145        | 2               | M10 x 25 long hexagon head bolt.   |
| 91              |                 | 2               | Spindle motor pivot pin locking washer.                                  |
| 92              |                 | 4               | M10 x 30 long hexagon head bolt.   |
| 93              |                 | 4               | 10mm washer.   |
| 94              | EM/72           | 1               | Motor pivot plate.   |
| 95              | 1085/54         | 1               | Spindle motor pivot pin.   |
| 96              |                 | 1               | Brook D100L, 3.7Kw(5HP) foot mounted, 3 phase, 50 cycle motor, STANDARD. |
|                 |                 | 1               | (State voltage required).  |
|                 |                 | 1               | Brook D100L, 3.7Kw(5HP) foot mounted, 3 phase, 60 cycle motor, EXTRA.    |
|                 |                 | 1               | (State voltage required).  |
|                 |                 | 1               | Brook D112M, 5.5Kw(7.5HP) foot mounted, 3 phase, 60 cycle motor, EXTRA.  |
|                 |                 | 1               | (State voltage required).  |
|                 |                 | 1               | Brook 132SB, 7.5Kw(10HP) foot mounted, 3 phase, 50 cycle motor, EXTRA.   |
|                 |                 | 1               | (State voltage required).  |
|                 |                 | 1               | Brook 132SB, 7.5Kw(10HP) foot mounted, 3 phase, 60 cycle motor, EXTRA.   |
|                 |                 | 1               | (State voltage required).  |
|                 |                 | 1               | Spacesaver "V" belt.   |
|                 |                 | 1               | Washer for motor pulley.   |
| 97              | SPZ-1010        | 1               | M12 x 30 long hexagon head bolt.   |
| 98              | EM/105          | 1               | Motor pulley, 4 speed, 50 cycle, (STANDARD).                             |
| 99              |                 | 1               | Motor pulley, 4 speed, 60 cycle. (EXTRA).                                |
| 100             | EM/70           | 1               | Motor pulley, 4 speed, 60 cycle. (EXTRA).                                |
|                 | EM/70           | 1               | Motor pulley, 5 speed, 50 cycle. (EXTRA).                                |
|                 | EM/71           | 1               | Motor pulley, 5 speed, 60 cycle, (EXTRA).                                |
| 101             | EM/71           | 1               | 7 x 8 x 30 long key.   |

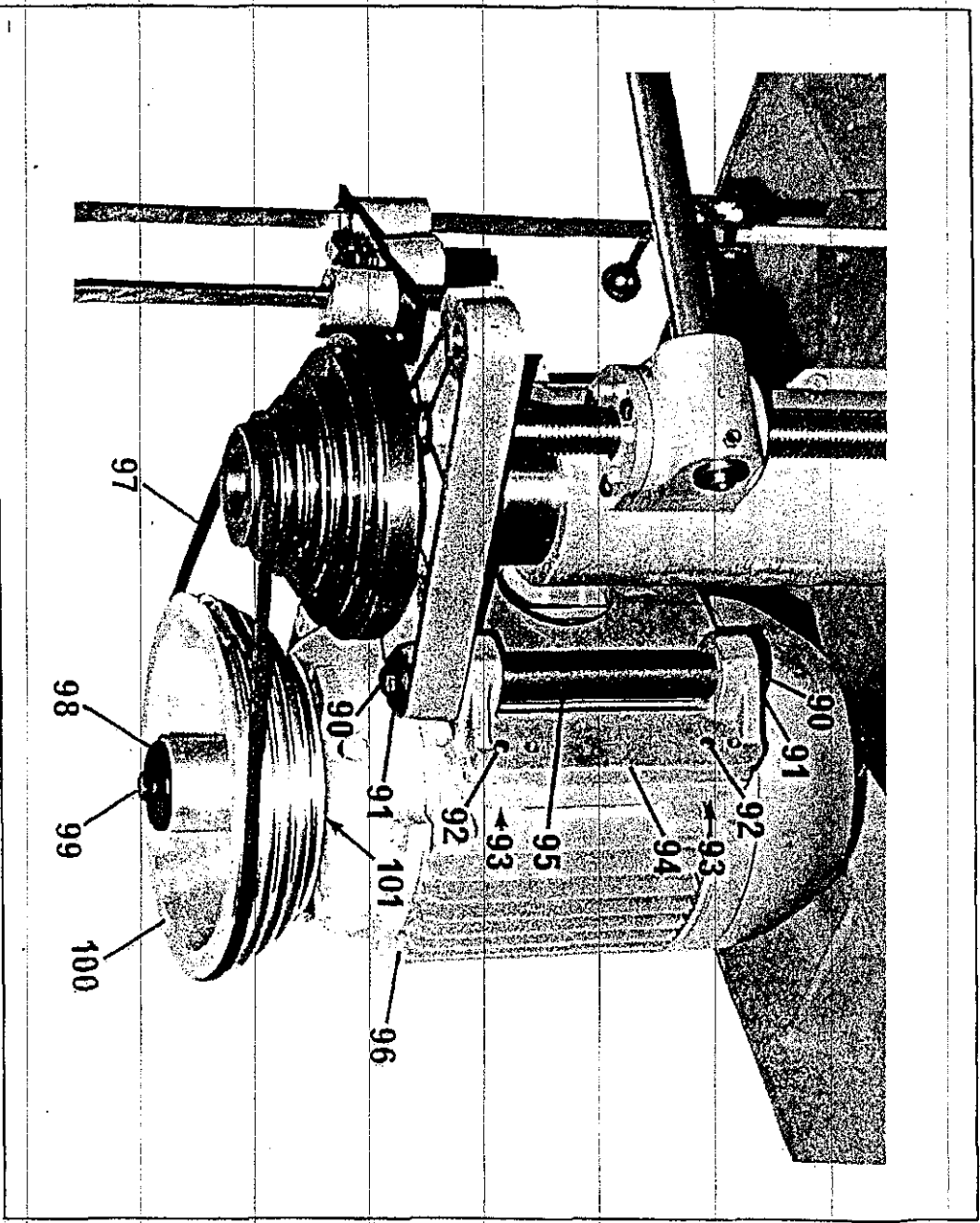

MOTOR MOUNTING ASSEMBLY

BELT TENSION AND SPINDLE LOCK ASSEMBLY.

| <u>Ref. No.</u> | <u>Part No.</u> | <u>No. Off.</u> | <u>Description.</u>                  |
|-----------------|-----------------|-----------------|--------------------------------------|
| 110             |                 | 1               | 1" dia plastic ball, M10 tap.        |
| 111             | EM/19           | 1               | Spindle lock handle.                 |
| 112             | EM/17           | 2               | Clamp plate for spindle lock handle. |
| 113             | EM/25           | 1               | Pivot pin for spindle lock handle.   |
| 114             |                 | 2               | M6 aertight nut.                     |
| 115             |                 | 2               | 6mm washer.                          |
| 116             |                 | 1               | M6 x 10 long socket head grubscrew.  |
| 117             | EM/16           | 1               | Torsion bar for lock.                |
| 118             |                 | 2               | M6 x 30 long hexagon head bolt.      |
| 119             | 1085/201        | 1               | Belt tension handle.                 |
| 120             | 1085/200        | 1               | Belt tension pivot boss.             |
| 121             |                 | 4               | M12 locknut.                         |
| 122             |                 | 2               | 12mm washer.                         |
| 123             | 1085/61         | 2               | Belt tension buffer.                 |
| 124             | 1085/80         | 1               | Belt tension bush and stop.          |
| 125             |                 | 1               | M10 x 65 long hexagon head bolt.     |
| 126             | 1085/172        | 1               | Belt tension link.                   |
| 127             |                 | 1               | M10 x 25 long hexagon head bolt.     |
| 128             |                 | 1               | M10 x 30 long hexagon head bolt.     |
| 129             |                 | 2               | 12mm washer.                         |
| 130             |                 | 1               | Spindle lock pivot.                  |
| 131             | EM/7            | 1               | M6 x 30 long hexagon head bolt.      |
| 132             |                 | 1               | M6 locknut.                          |
| 133             | EM/48           | 1               | Pivot plate for brake and lock.      |
| 134             | 7100-025        | 2               | External circlip.                    |
| 135             | ENTEX/118       | 1               | Compression spring.                  |
| 136             | EM/28           | 1               | Spindle lock plunger.                |
| 137             | EM/8            | 1               | Brake shoe complete with Ferodo pad. |
| 138             | EM/15           | 1               | Torsion bar for brake.               |

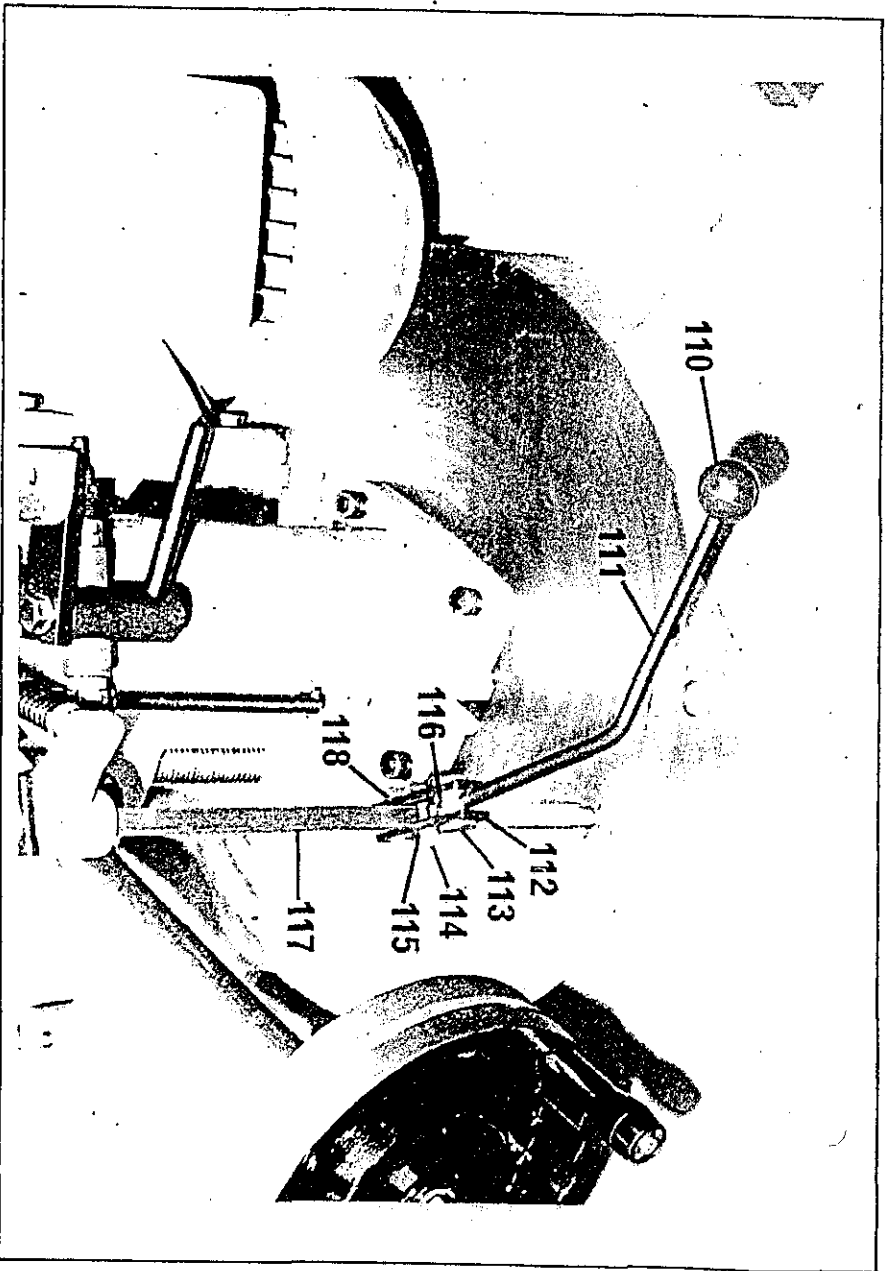

BELT TENSION AND SPINDLE LOCK ASSEMBLY

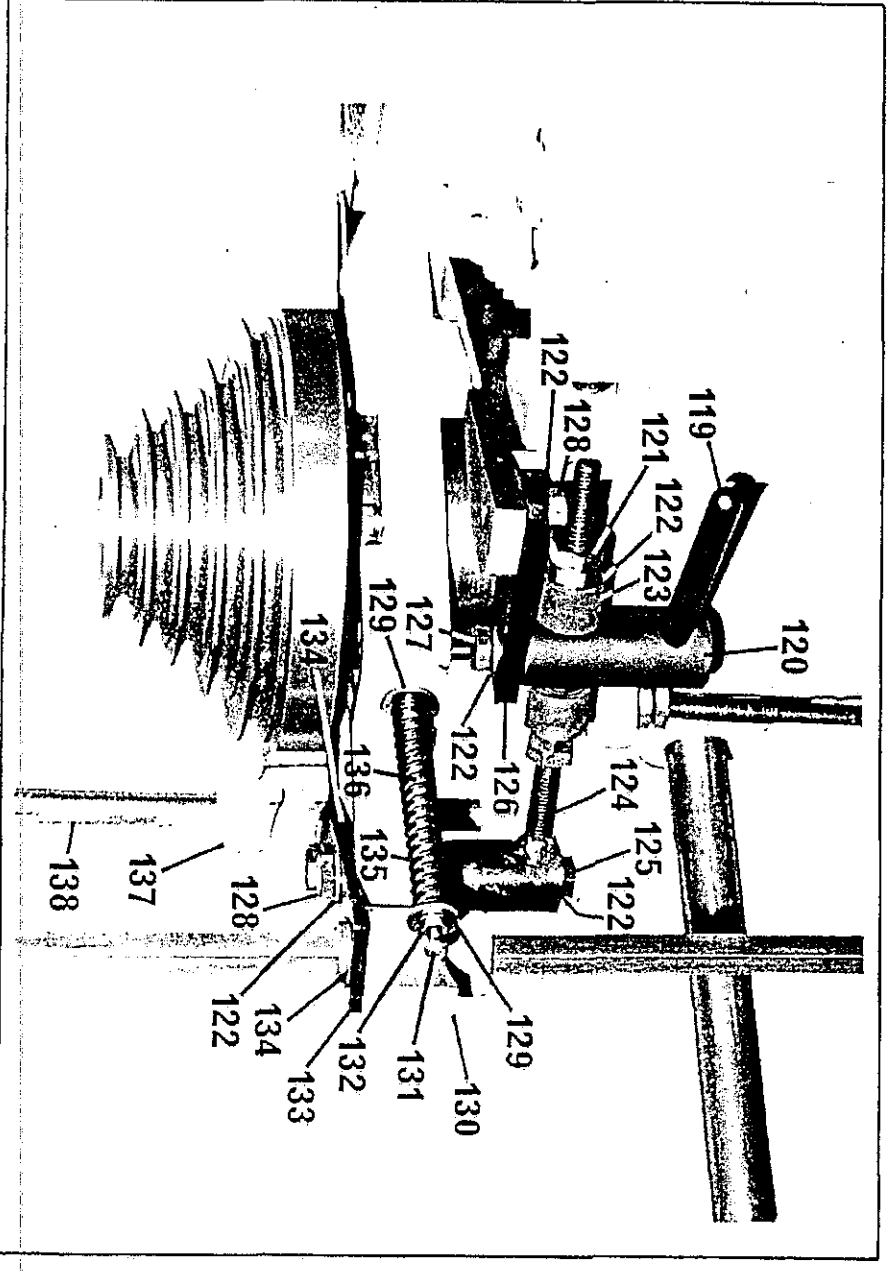

BRAKE ASSEMBLY.

| <u>Ref. No.</u> | <u>Part No.</u> | <u>No. Off.</u> | <u>Description.</u>                                 |
|-----------------|-----------------|-----------------|---|
| 150             | EM/3            | 1               | Brake pedal.  |
| 151             |                 | 2               | M8 x 30 long hexagon head bolt.                     |
| 152             | EM/29           | 2               | Pivot for brake pedal.                              |
| 153             | EM/18           | 1               | Brake connecting rod.                               |
| 154             |                 | 1               | 3BR Micro Burgess limit switch.                     |
| 155             |                 | 2               | M4 x 30 long pan head screw, 4mm washer and M4 nut. |
| 156             |                 | 2               | 12mm washer.  |
| 157             |                 | 1               | M6 x 25 long hexagon head bolt and M6 locknut.      |
| 158             |                 | 3               | M12 nut.  |
| 159             |                 | 2               | M12 x 50 long hexagon head bolt.                    |
| 160             | EM/39           | 1               | Limit switch bracket.                               |
| 161             |                 | 4               | M6 aerotight nut.                                   |
| 162             |                 | 2               | 6mm washer.   |
| 163             |                 | 4               | M6 x 30 long hexagon head bolt.                     |
| 164             | EM/33           | 1               | Clamp plate for limit switch.                       |
| 165             | 7100/025        | 1               | 25mm external circlip.                              |
| 166             | EM/106          | 1               | Washer for brake pivot.                             |
| 167             | ENTEX/94        | 1               | Compression spring.                                 |
| 168             |                 | 1               | 8mm washer.   |
| 169             |                 | 5               | M8 locknut.   |
| 170             | EM/73           | 1               | Plate for brake pedal return spring.                |
| 171             | ENTEX/589       | 1               | Tension spring.                                     |
| 172             |                 | 1               | M6 x 25 long socket head capcrew.                   |
| 173             | EM/9            | 1               | Brake pivot.  |
| 174             | EM/34           | 1               | Adjusting plate for limit switch.                   |

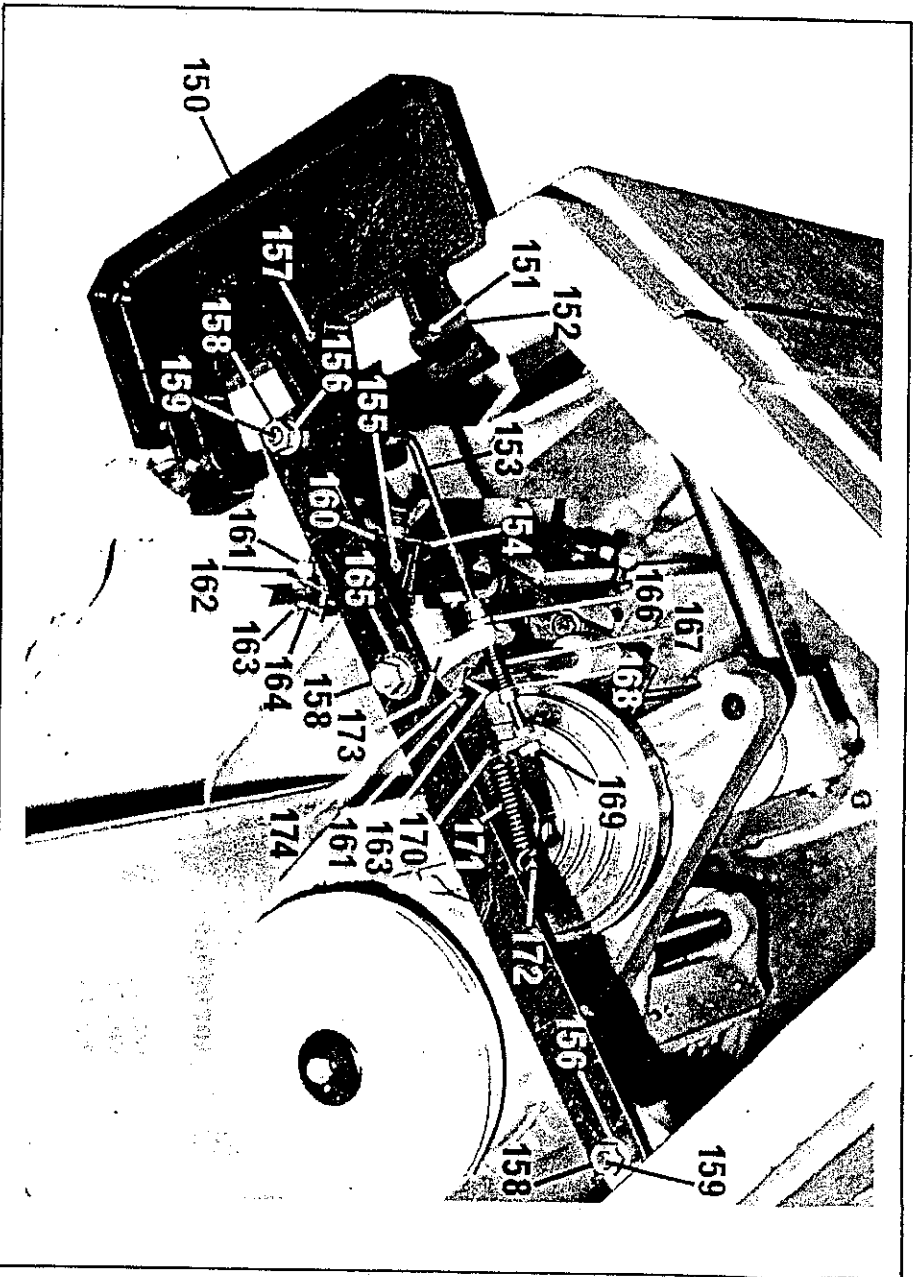

BRAKE ASSEMBLY (VIEW FROM UNDERSIDE OF MACHINE)

FENCE ASSEMBLY.

| <u>Ref No.</u> | <u>Part No.</u> | <u>No. Off.</u> | <u>Description.</u>                        |
|----------------|-----------------|-----------------|--|
| 180            | EM/87           | 1               | Right hand fence plate.                    |
| 181            | 1026-396        | 2               | Washer.                                    |
| 182            |                 | 2               | M12 nut.                                   |
| 183            |                 | 2               | M12 x 40 long hexagon head bolt.           |
| 184            |                 | 2               | Fence plate bracket.                       |
| 185            | EM/66           | 4               | Adjustable handle, M12 tap.                |
| 186            |                 | 2               | M12 x 50 long stud.                        |
| 187            |                 | 2               | M12 x 12 long socket head grubscREW.       |
| 188            | 1026/22         | 4               | Washer.                                    |
| 189            | EM0022          | 2               | M12 x 170 long stud.                       |
| 190            | K5127199        | 2               | Plastic handwheel M12 tap.                 |
| 191            |                 | 2               | M12 x 45 long stud.                        |
| 192            | EM/62           | 2               | Fence adjusting screw.                     |
| 193            | 7100-020        | 2               | External circlip.                          |
| 194            | EM/64           | 2               | Bush for adjusting screw.                  |
| 195            | EM/63           | 2               | Collar for fence adjusting screw.          |
| 196            |                 | 4               | 3 dia x 30 long groverlok spring<br>dowel. |
| 197            | 1079/949        | 2               | Graduated collar.                          |
| 198            |                 | 2               | Plastic handwheel, 12mm plain bore.        |
| 199            | EM/93           | 1               | Top cover.                                 |
| 200            | EM/65           | 1               | Fence.                                     |
| 201            | EM/86           | 1               | Left hand fence plate.                     |

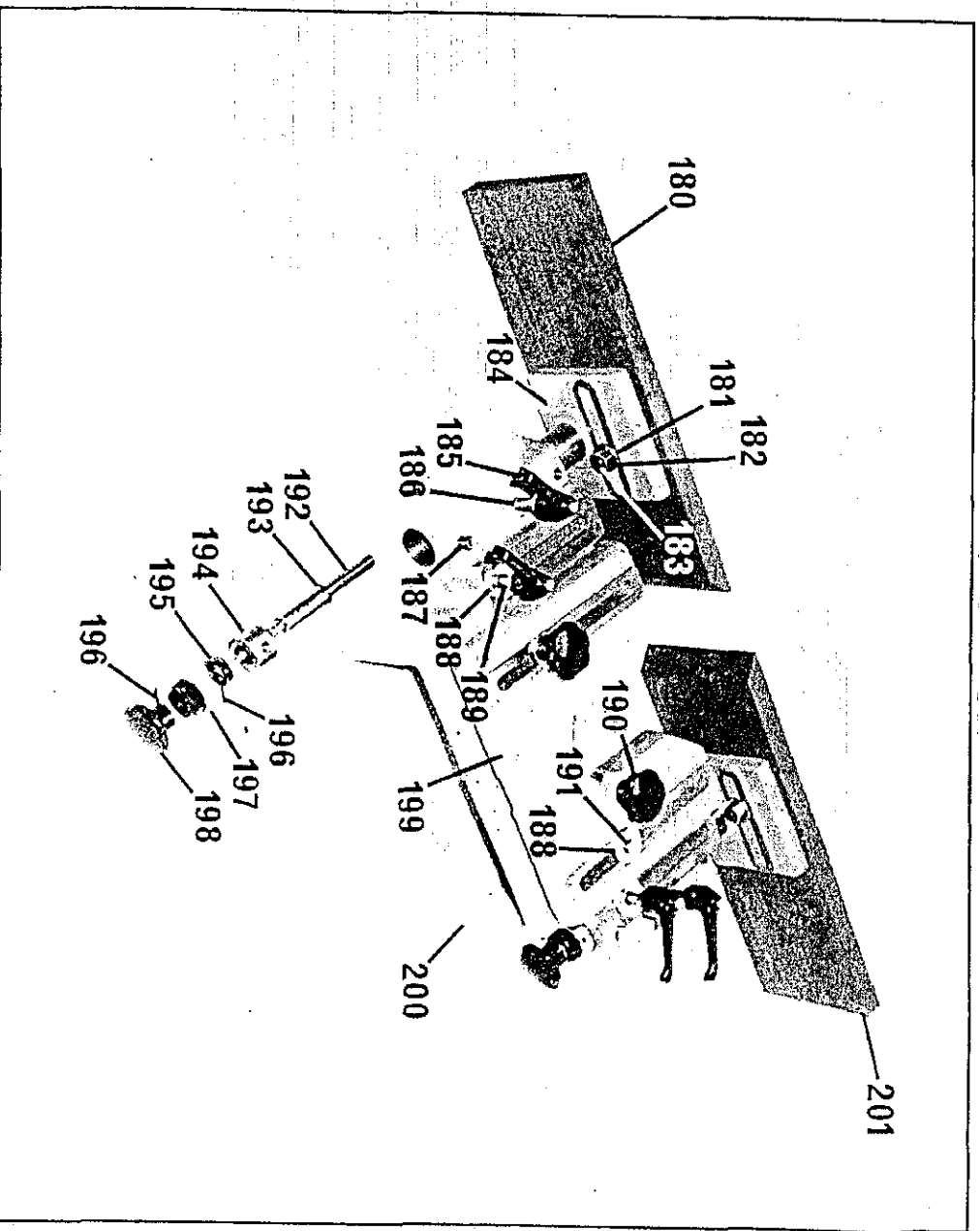

FENCE ASSEMBLY

TABLE RING CAM LOCK ASSEMBLY.

| <u>Ref No.</u> | <u>Part No.</u> | <u>No. Off.</u> | <u>Description.</u>                 |
|----------------|-----------------|-----------------|-------------------------------------|
| 210            | EM/54           | 2               | Collar for cam lock.                |
| 211            | EM/55           | 1               | Cam lock for table ring.            |
| 212            |                 | 2               | M6 x 10 long socket head grubscrew. |
| 213            |                 | 3               | M12 nut.                            |
| 214            | EM/116          | 3               | Seating bolt for table ring.        |
| 215            |                 | 2               | M6 x 15 long socket head grubscrew. |
| 216            | EM/81           | 1               | Handle for cam lock.                |

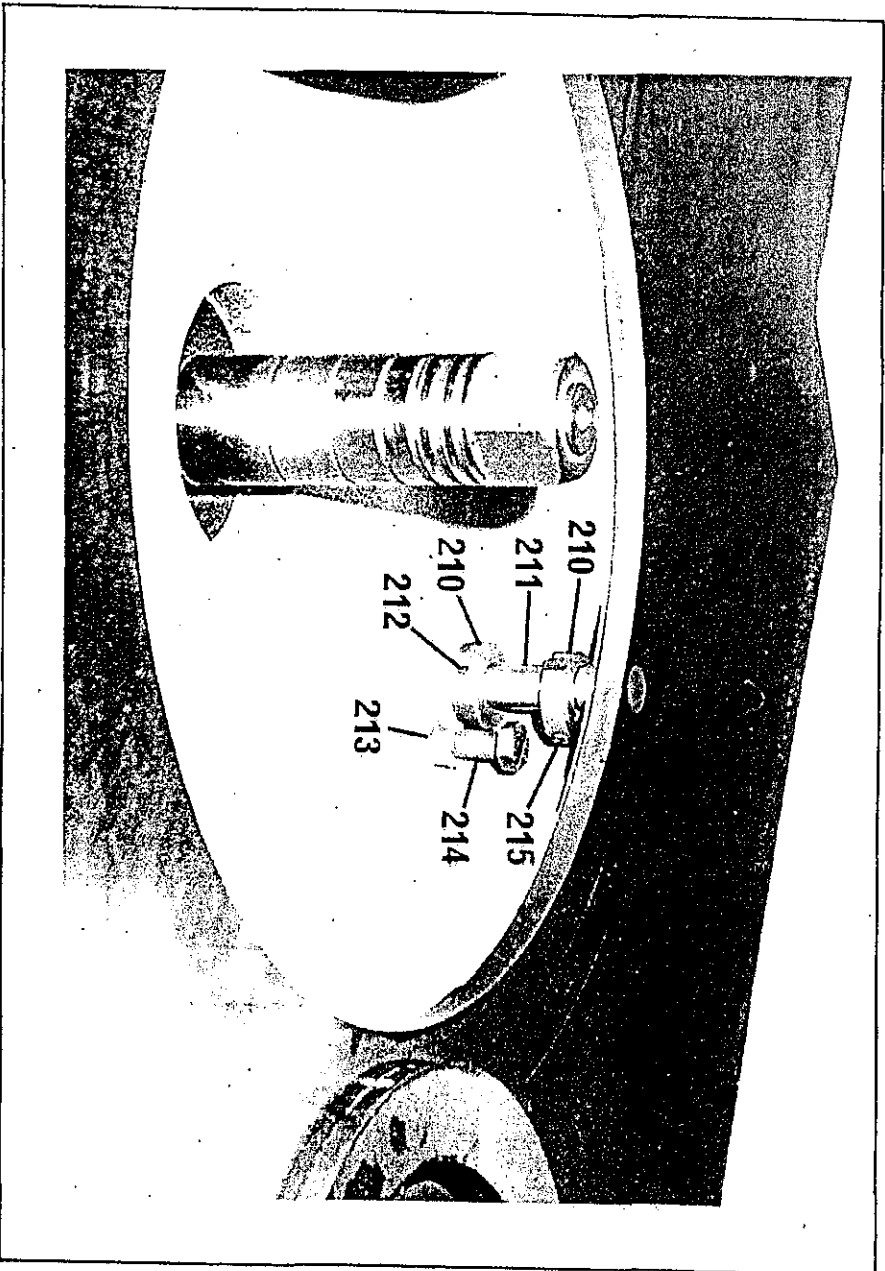
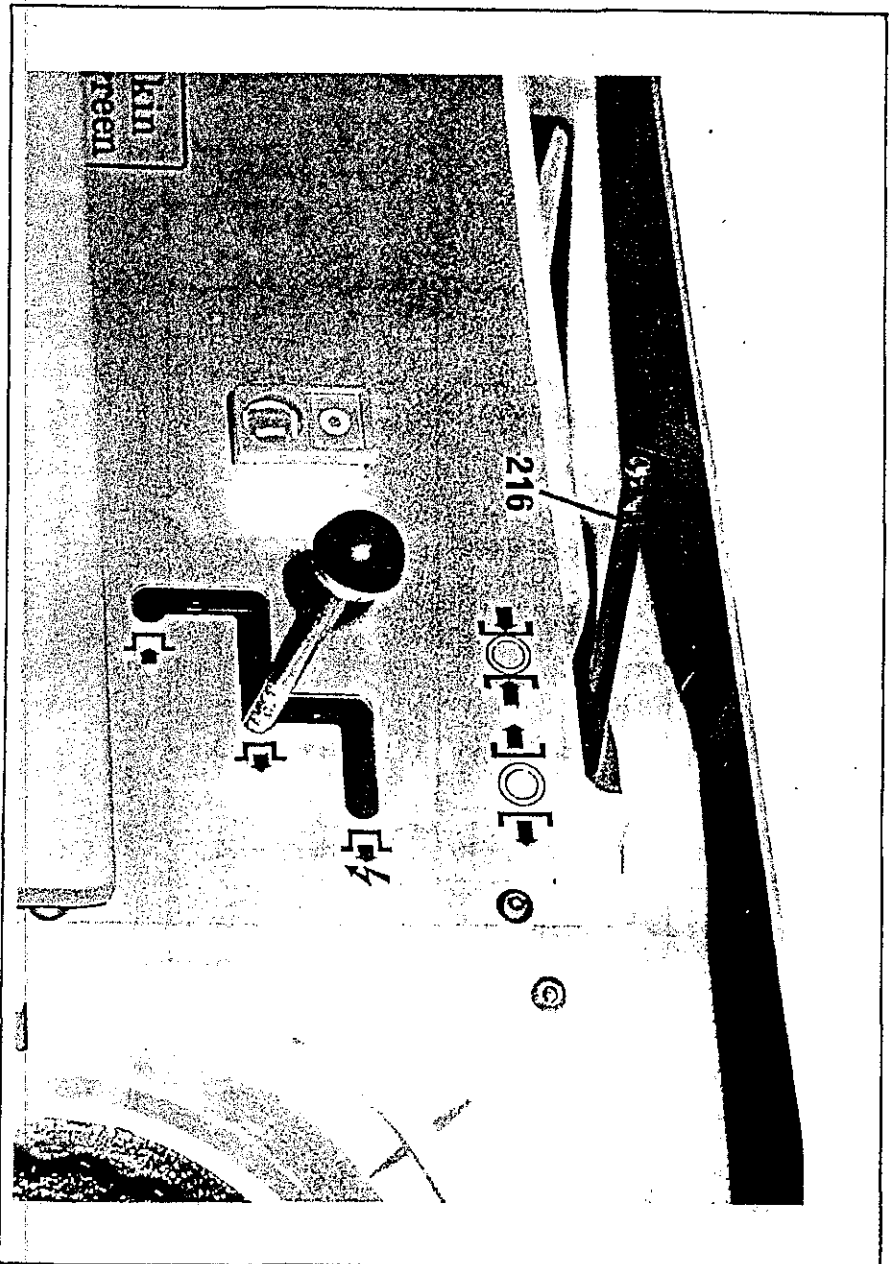
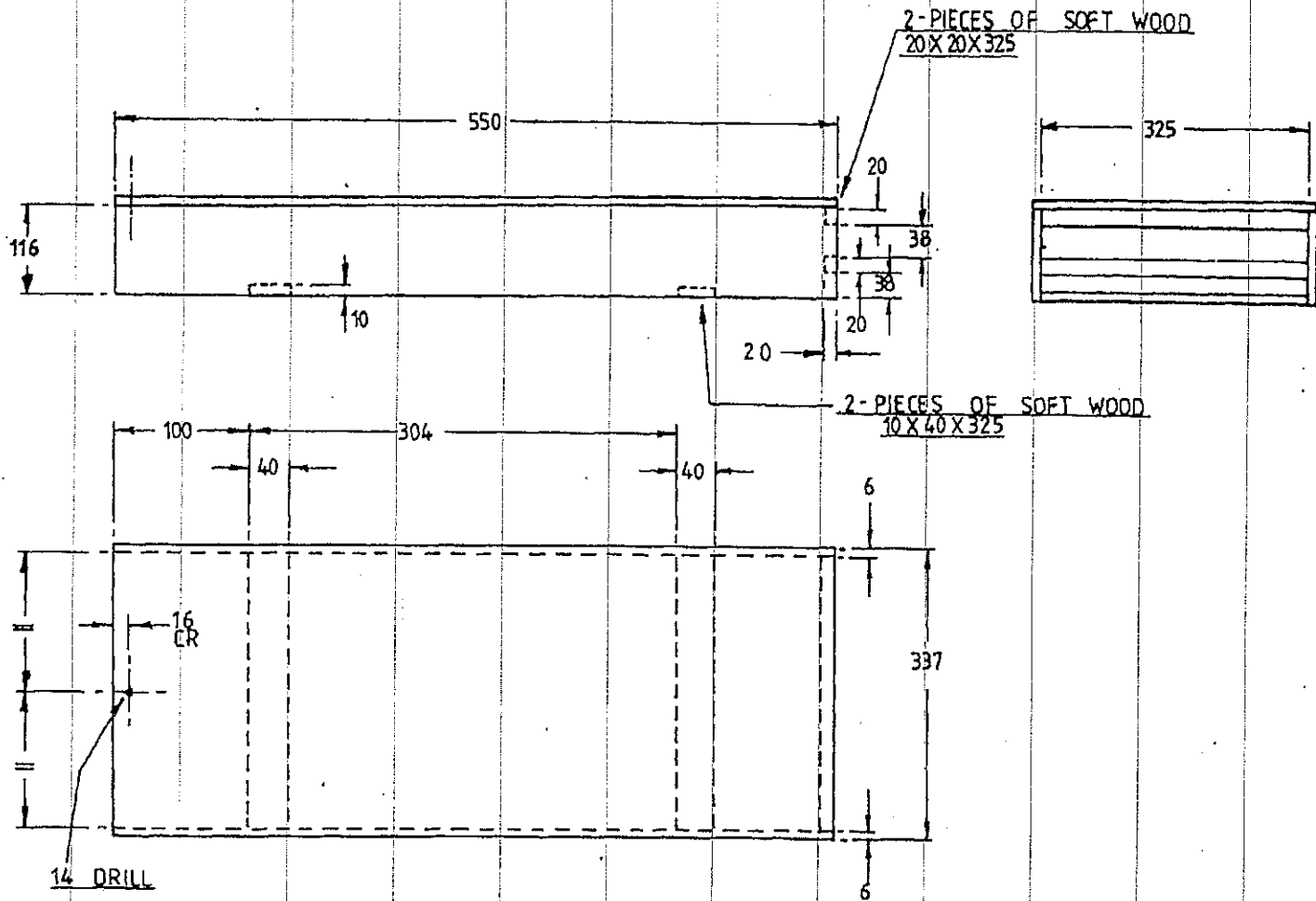

TABLE RING CAM LOCK ASSEMBLY



| Application              | Approved Lubricant    |                     |              |                                  |                   |        |
|--------------------------|-----------------------|---------------------|--------------|----------------------------------|-------------------|--------|
|                          | Castrol               | B. P.               | Shell        | Esso                             | Texaco/<br>Caltex | Wadkin |
| Worm Boxes               | Alpha 617             | Energol CS425       | Vitrea 75    | Pen-O-Led<br>E. P.3              | Regal<br>Oil J    | L. 2.  |
| General<br>Lubrication   | Magna ED              | Energol<br>HP. 20   | Vitrea 33    | Esstic 50                        | Ursa Oil<br>P. 20 | L. 4.  |
| Pneumatic<br>Lubricators | Hyspin<br>AWS 32      | Energol<br>HL 65    | Tellus<br>27 | Nuto<br>H 44                     | Rando<br>Oil HDA  |        |
| Grease                   | Spheerol<br>AP. 3     | Energrease<br>LS. 3 | Alvania 3    | Beacon 3<br>Starfak<br>Premium 3 | Regal             | L. 6.  |
| Brake<br>Cables          | Brake cable<br>grease | Energrease<br>L21M  | Alvania<br>3 | Multi-purpose<br>grease H        |                   |        |



REAR GUARD FOR FENCE

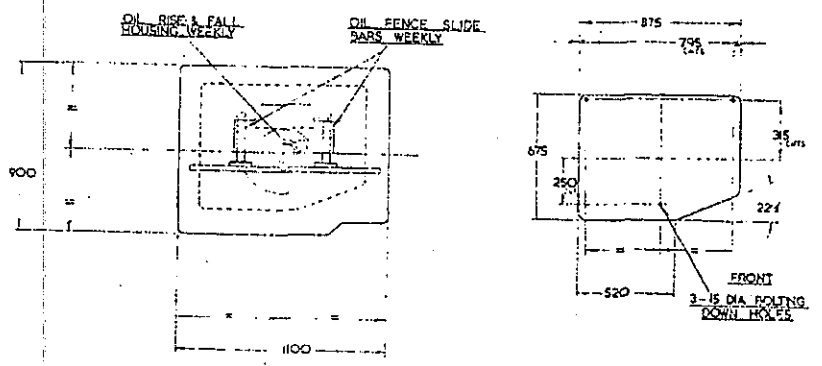
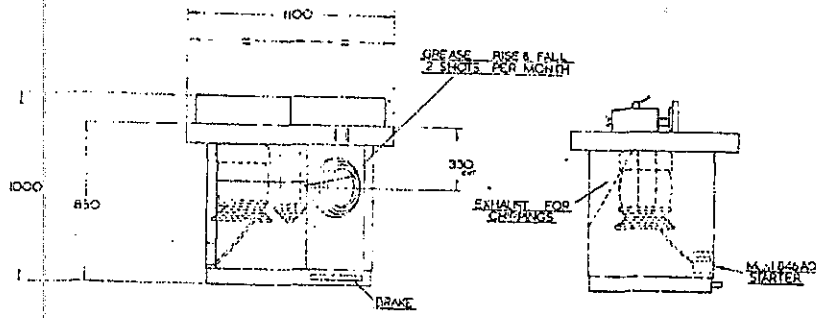

SPECIFICATION

|   |                              |
|---|------------------------------|
| DIAMETER OF TOP PIECE                       | 30                           |
| DIAMETER OF TOP PIECE (OPTIONAL)            | 50 35+ GR 114                |
| TABLE DIMENSIONS                            | 1100 / 900                   |
| TABLE HEIGHT                                | 180                          |
| VERTICAL MOVEMENT OF SPINDLE                | 185                          |
| SPEED OF SPINDLE STD                        | 3000 4500 6000 7200RPM       |
| SPEED OF SPINDLE (EXTRA)                    | 3000 4500 6000 7200 12000RPM |
| MOTOR OUTPUT                                | 5HP                          |
| MOTOR OUTPUT (OPTIONAL)                     | 7.5HP OR 10HP                |
| MAX DIA OF TOOLING ACCOMMODATED UNDER TABLE | 420                          |
| FIVE CIRCULAR TABLE RINGS GIVING OPENING OF | 150 200 260 340 450 DIA      |
| SOLID ONE PIECE CAST IRON FRAME             |                              |
| ELECTRICALLY INTERLOCKED FOOT BRAKE         | ALL AS STANDARD              |
| ELECTRICALLY INTERLOCKED CONTROL LEVER      |                              |

BEARINGS USED - 2-SKF 600 2Z BEARINGS  
 1-SKF 6208 2Z BEARINGS  
 1-SKF 3107X THRUST RACE  
 2-SKF 5104 THRUST RACE

BELT USED - 1-FENNER ALPHA 400 SPACESHED VEE BELT

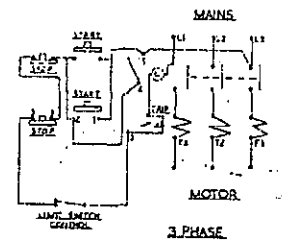

TYPE OF GREASE RECOMMENDED - SHELL ALVANIA 3  
 TYPE OF OIL RECOMMENDED - POWER EM 125

|   |          |                    |        |                   |      |              |  |
|---|----------|--------------------|--------|-------------------|------|--------------|--|
| TITLE: SHELLE MOLDER FOUNDATION DRAWING |          | SUSSEEN DESIGN LTD |        | FOUNDATION SPRING |      | FENCE HOUSES |  |
| FOUNDATION DRAWING                      | TYPE BEM | DATE               | 3-4-79 | SCALE             | 10-1 | EM/FD        |  |
|   |          | DRAWN BY           | DH     |                   |      |              |  |