

Modifications are made to these books from time to time and it is important therefore that only the book sent with the machine should be used as a working manual

PLEASE INSERT SERIAL NUMBER OF MACHINE

INSTRUCTION MANUAL FOR

400 BRA

Universal Radial Arm Saw

Specification

Maximum diameter of saw.....	400mm	400mm
Maximum saw projection.....	133mm	5in.
Width will cross cut with standard arm at 90°.....	305x133mm	12x5in.
Width will cross cut with standard arm at 90°.....	380x25mm	15x1in.
Width will cross cut with standard arm at 45°.....	110x133mm	4½x5in.
Maximum width grooving head.....	265x25mm	10½x1in.
Maximum ripping capacity.....	32mm wide	1¼in.
Height of work table.....	730mm	29in.
Diameter of saw spindle.....	825mm	32½in.
Power of motor.....	25mm	1½HP 30kW
Speed of motor 50 hertz.....	3000rev/min.	3000rev/min.
Speed of motor 60 hertz.....	3600rev/min.	3600rev/min.
Maximum overall height.....	1830mm	72in.
Floor space.....	1570x1070mm	62x42in.
Net weight(approx).....	220kg.	490lb.
Gross weight(approx).....	285kg/3	630lb/3.
Shipping dimensions(approx).....	0.70m	25ft.

NOTE:

On 400mm(16in) machine special spigotted saw flanges are fitted to take 32mm(1¼in) bore saws.

**For Replacement Parts, Tools & Accessories,
Contact Brian Stacey,
Bursgreen (Durham) Ltd.,
Fence Houses, Houghton-le-Spring,
Tyne ~ Wear DH4 5RQ, England.
Telephone: Fence Houses 2385 (5 Lines)
Telex: 53441 (Bursgreen Duram)**

SAFETY

1. Read Instruction Book.
2. Securely Lock Cutters.
3. Set Guards Correctly.
4. Select Correct Speed.
5. Use Feeding Devices Where Possible.
6. Refer To HSW Booklet No.41. (in UK) For Safety In The Use Of Woodworking Machinery.

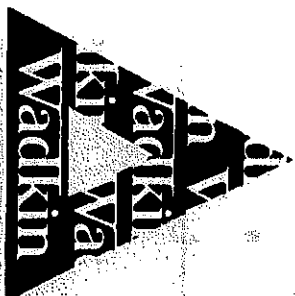

HEALTH & SAFETY

SAFETY OF WOODWORKING MACHINES

Woodworking machines can be dangerous if improperly used. The wide range of work of which they are capable, requires adequate safeguarding arrangements against possible hazards.

Many injuries to machinists are caused by carelessness or failure to use the guards provided or to adjust them correctly.

WADKIN LTD., supply machinery designed for maximum safety which they believe, as a result of thorough testing, minimizes the risks inevitable in their use. It is the user's responsibility to see that the following rules are complied with to ensure safety at work:

1. The operation of the machine should conform to the requirements of the Woodworking Machines Regulations 1974. All guards should be used and adjusted correctly.
2. Safe methods of working only should be adopted as given in the Health and Safety Work Booklet No.41, "Safety in the Use of Woodworking Machines" (obtainable from Her Majesty's Stationary Office) and as advised by Wadkin Ltd.
3. Only personnel trained in the safe use of a machine should operate it.
4. Before making adjustments or clearing chips, etc., the machine should be stopped and all movement should have ceased.
5. All tools and cutters must be securely fixed and the speed selected must be appropriate for the tooling.

SAFETY IS OUR WATCHWORD BUT THE USER MUST COMPLY WITH THE ABOVE RULES IN HIS OWN INTEREST. WE WOULD BE PLEASED TO ADVISE ON THE SAFE USE OF OUR PRODUCTS.

000

Application	Approved Lubricant					
	Castrol	B. P.	Shell	Esso	Texaco/ Caltex	Wadkin
Worm Boxes	Alpha 617	Energol CS425	Vitrea 75	Pen-O-Led E. P. 3	Regal Oil J	L. 2.
General Lubrication	Magna ED	Energol HP. 20	Vitrea 33	Esstic 50	Ursa Oil P. 20	L. 4.
Pneumatic Lubricators	Hyspin AWS 32	Energol HL 65	Tellus 27	Nuto H 44	Rando Oil HDA	
Grease	Spheerol AP. 3	Energrease LS. 3	Alvania 3	Beacon 3 Starfak Premium 3	Regal	L. 6.
Brake Cables	Brake cable grease	Energrease L21M	Alvania 3	Multi-purpose grease H		

Universal Radial Arm Saw Type BRA 400

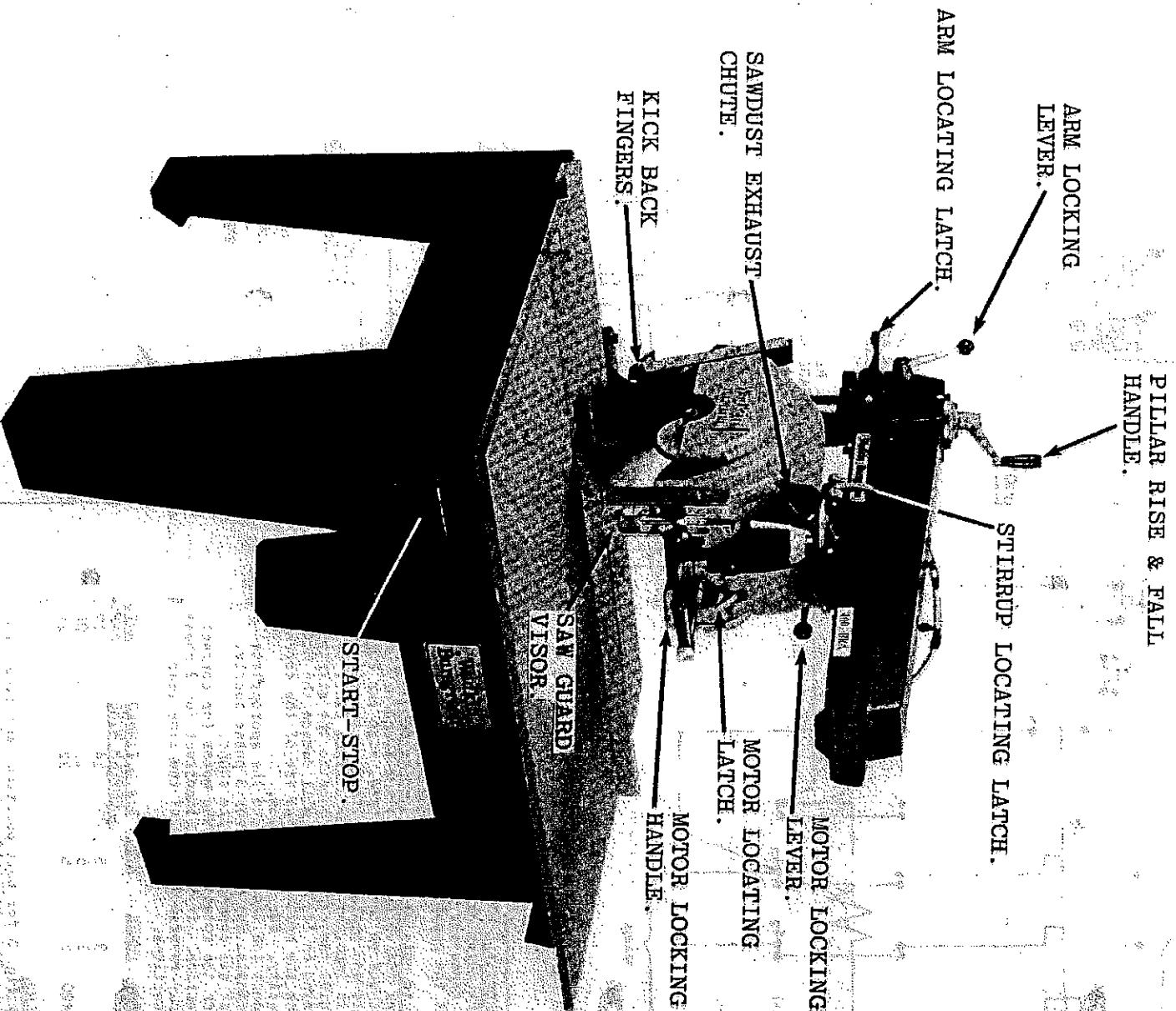

SAW GUARD VISOR
START-STOP
MOTOR LOCKING HANDLE
MOTOR LOCATING LATCH
MOTOR LOCKING LEVER
STIRRUP LOCATING LATCH
PILLAR RISE & FALL HANDLE
ARM LOCATING LATCH
ARM LOCKING LEVER

INSTALLATION

Remove protective coating from bright parts by applying a cloth soaked in paraffin, turpentine or some other solvent.

When the machine is cased for export the carriage and motor unit is removed from the arm, the arm is removed from the pillar, the pillar and foot assembly is removed from the base along with the legs. All these items are packed individually in the case. Remove and assemble as shown in Fig. 1.

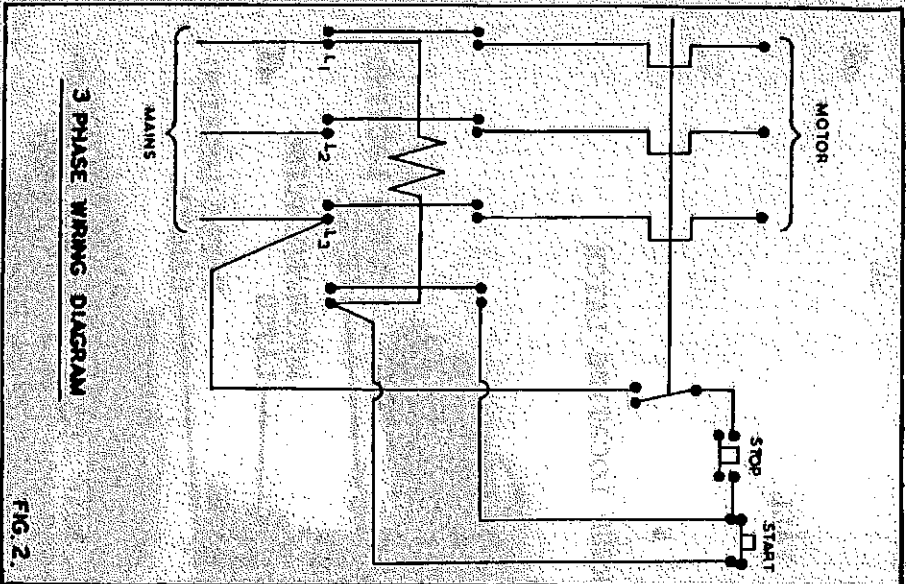

WIRING DETAILS

The motor and control gear have been wired in before despatch. All that is required is to connect the power supply to the starter.

- Points to note when connecting to power supply:-
1. Check the voltage, phase and frequency correspond to those on the motor plate, also the correct coils and heaters are fitted to the starter.
 2. It is important that the correct cable is used to give the correct voltage to the starter, as running on low voltage will damage the motor.
 3. Check the main line fuses are of the correct capacity. See list below.
 4. Connect the line leads to the appropriate terminals. See Fig. 2 for 3 phase supply.
 5. Check all connections are sound.
 6. Check the rotation of the motor for correct direction. If this is incorrect for 3 phase supply reverse any two of the line lead connections.

VOLTAGE	PHASE	H.P.	S.W.G. TINNED COPPER WIRE	AMPS
550	3	5	24	17
220	3	5	19	38
380/420	3	5	22	24

FOUNDATION

See Fig. 5 for bolt positions and clearance required. When installing the machine must be levelled up by means of packing pieces under the feet. The machine table should be slightly high at the front end. This will ensure that the saw unit remains in the back position when not in use. This does not affect the accuracy of the machine. Foundation bolts are not supplied with the machine except by special order.

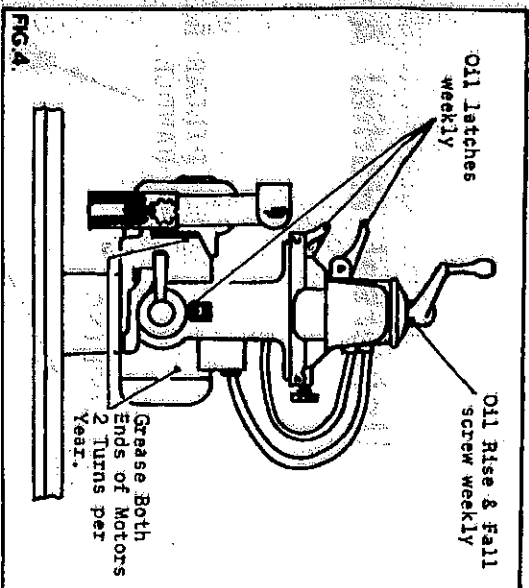

LIBRICATION

It is advisable to keep all bright parts covered with a thin film of oil to prevent rusting. The slide rods and rollers should also be kept clear of any sawdust and chippings for ease of operation.

TYPE OF OIL RECOMMENDED
TYPE OF GREASE RECOMMENDED

POWER EM.125
SHELL ALVANIA 3.

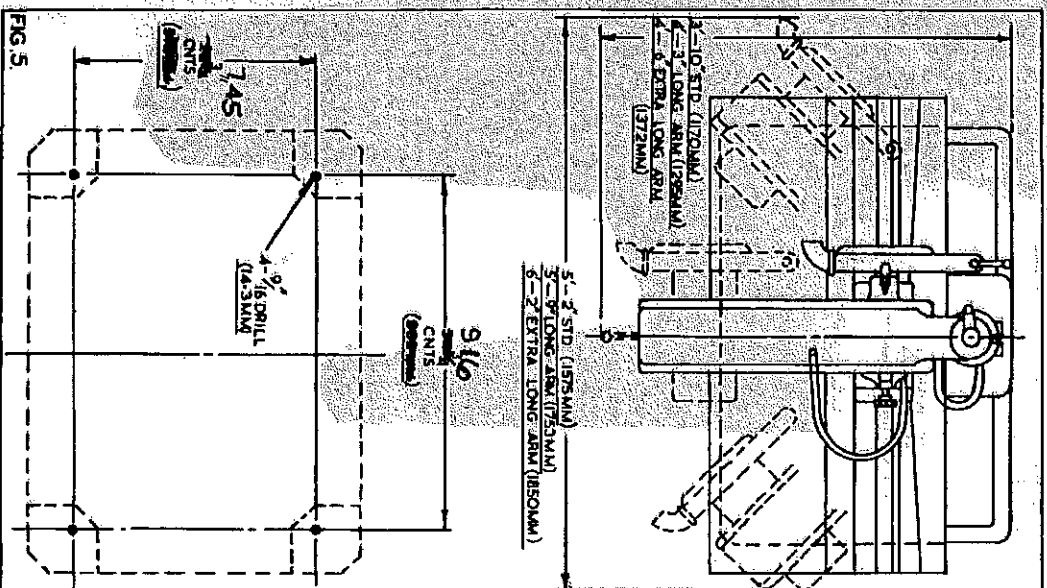

All adjustments and alignments listed below have been carefully set and checked and the whole machine thoroughly tested before despatch from the works. Should any adjustment be necessary proceed in accordance with the relative instructions given.

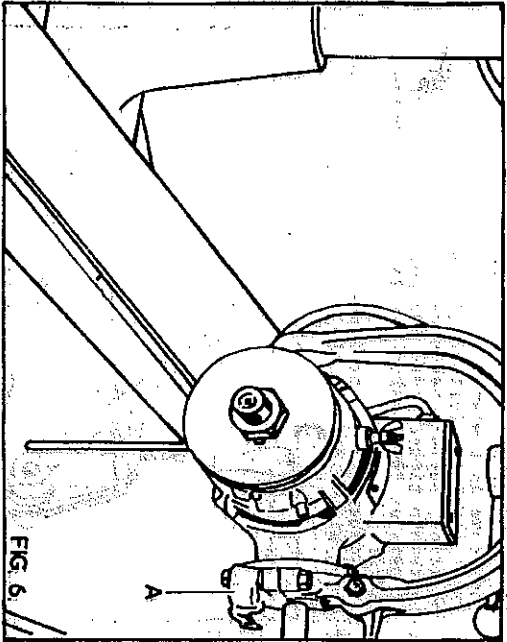

FIG. 6.

LEVELLING TABLE

To check the table for alignment to the arm the undermentioned procedure should be followed:-

1. Remove the sawguard and blade from the motor.
2. Ensure the motor locating latch "A" in Fig. 9, the stirrup locating latch "B" and the carriage locking screw "C" in Fig. 16 is securely locked.
3. Secure a small dia. rod between saw flanges as shown in Fig. 6 then raise or lower arm until end of the rod almost touches table.
4. Lift arm locating latch "C" in Fig. 9 and swing arm to extreme ends of the table checking that clearance between rod and table remains constant.
5. Should the table need adjustment remove table packing pieces and fence, adjust table supports by loosening hexagon head bolts and moving up or down whichever is required. When set tighten all bolts.
6. Replace fence in position required and replace packing pieces and wedges.

SAWBLADE ALIGNMENTS

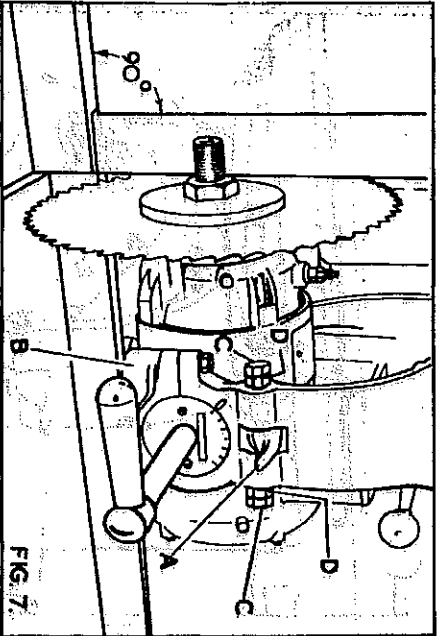

FIG. 7.

1. Saw square to table

To check this alignment, place a steel square against the saw as shown in Fig. 7. If adjustment is necessary, disengage the motor locating latch "A", loosen motor pivot locking handle "B" and adjust sawblade until square. Lock in this position with lever "B", then adjust serotight hexagon nuts "C" and lever "D" until latch "A" locates accurately in the motor locating ring.

2. Line of travel to fence

To check this alignment place a pencil between the saw flanges, as shown in Fig. 8, and scribe a line on the table. Check this is at 90° to the fence by means of a steel square. If adjustment is necessary loosen arm locking lever "A" in Fig. 8 and disengage the pillar locating latch "B", adjust arm until square, lock in position; then adjust serotight hexagon nuts "C" and hexagon locknuts "D" until the latch "B" locates accurately in the pillar.

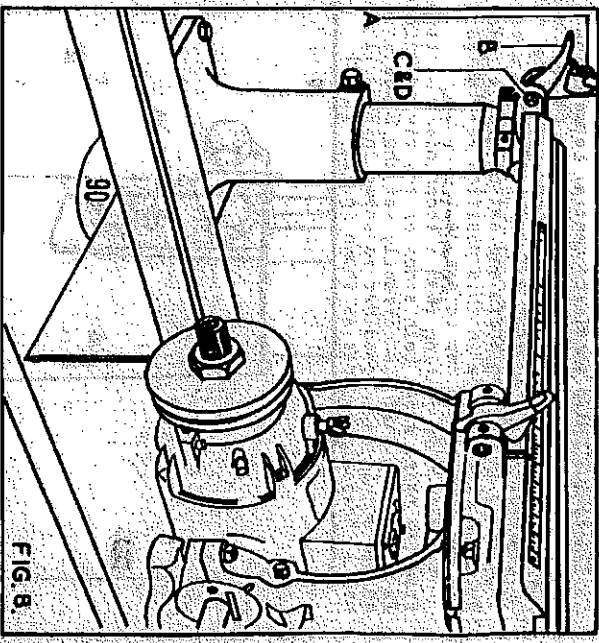

FIG. 8.

3. Sawblade in relation to fence.

To check this alignment place a steel rule or some other similar straight edge between the saw flanges as shown in Fig. 9 and a steel square against the fence. Rotate the steel rule from front to rear. If adjustment is necessary loosen stirrup locking handle "D", and disengage the stirrup locating latch "B", set correctly, then relock in position with lever "B". Adjust the serotight nuts "E" and hexagon locknuts "F" until the latch "B" locates accurately in the slot in the stirrup.

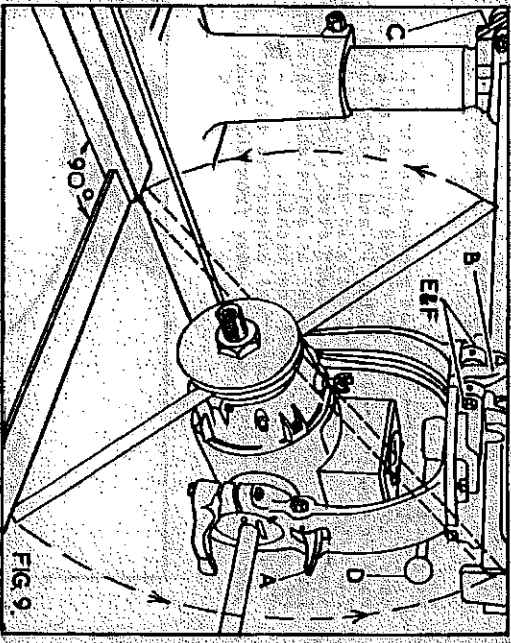

FIG. 9.

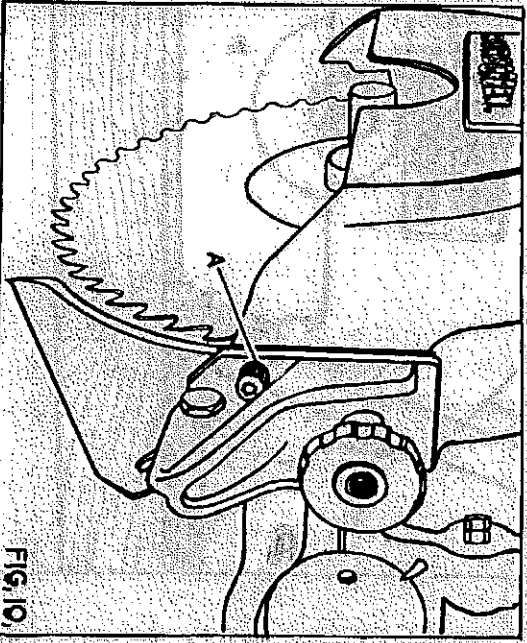
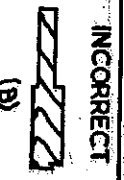

FIG. 10.



CORRECT



INCORRECT

FIG. 11.

RYING KNIFE ALIGNMENT

The riving knife should be central between the set of the saw. Should the riving knife be incorrectly positioned loosen the two socket head cap screws "A" in Fig. 10. Place a steel rule or some other straight edge along the riving knife and set central to saw with the riving knife in this position re-tighten the two socket head cap screws "A".

To check this setting feed a short piece of timber from the rear, along both sides of the riving knife. If the riving knife is correctly set the blade should cut an equal shoulder as shown in Fig. 11 (a) not an unequal shoulder as shown in Fig. 11 (b).

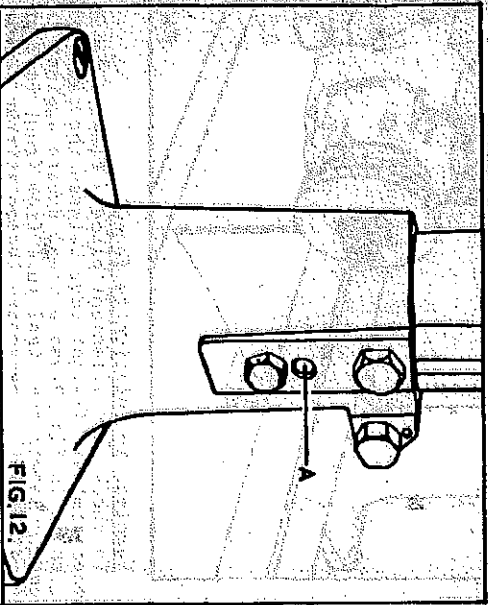
**COLUMN ADJUSTMENTS**

Movement in the arm may be traced to the pillar. To take up any play which may develop adjust the special socket head cap screw "A" in Fig. 12. After adjustment the pillar rise and fall should be checked to ensure the movement is not too tight.

SAW GUARD

The guard gives maximum protection for all operations. The guard is fitted with an anti-kick back device as shown in Fig. 13 and riving knife for ripping. The riving knife is easily detachable and can be replaced by a sheet steel visor when used for crosscutting. The visor is adjustable throughout the full depth of cut of the machine.

An adjustable rubber dust exhaust is fitted to the guard to direct the sawdust away from the operator.

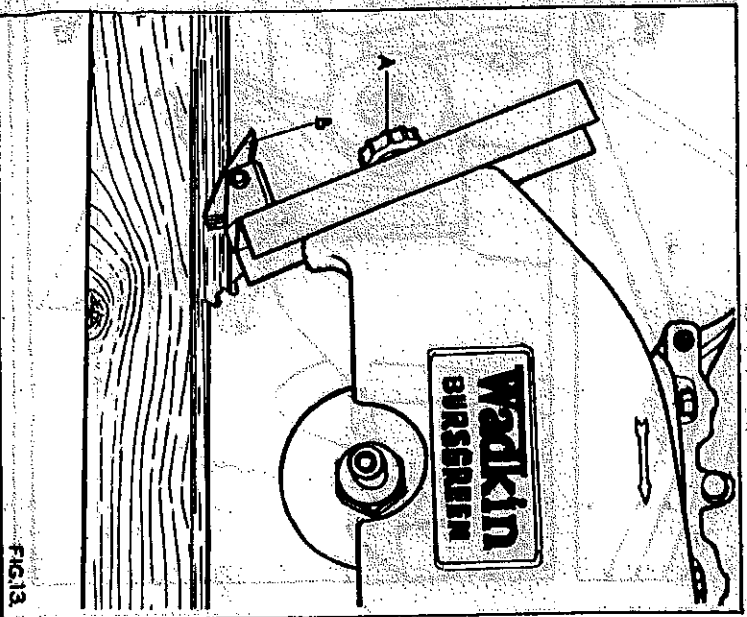
**HOW TO ADJUST KICK BACK FINGERS**

The anti-kick back fingers are fitted to the saw guard and they are adjustable throughout the full depth of cut of the machine.

- To set kick back fingers correctly:-
1. Place timber to be ripped in kick back fingers as shown in Fig. 13.
 2. Loosen handwheel "A" then lower the fingers until they come in contact with the timber. Press bracket a further 1/4" (3mm) hold in that position, re-lock handwheel "A".
 3. To remove timber press the point of kick back fingers at "B" towards the table and withdraw the timber.

The timber can now be ripped without any danger of it being kicked back at the operator.

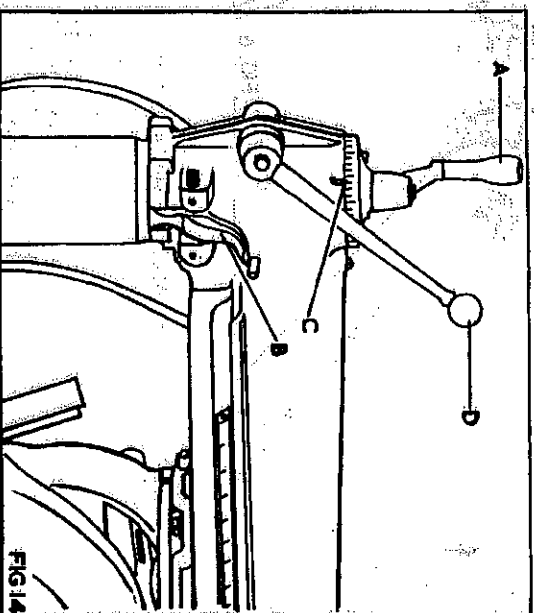
**RISE AND FALL OF THE ARM**

The arm rise and fall is by means of the handle "A" in Fig. 14. The handle turns a screw in a brass nut which is anchored to the foot. The total travel of the arm is 14" (356mm).

SWIVEL OF THE ARM

The arm swings 45° each way to the fence with the principle angles located by a tapered latch "B" in Fig. 14. The angles to the fence line are indicated by a pointer on the arm bearing cap at "C".

A powerful lock is provided and can be applied by lever "D".

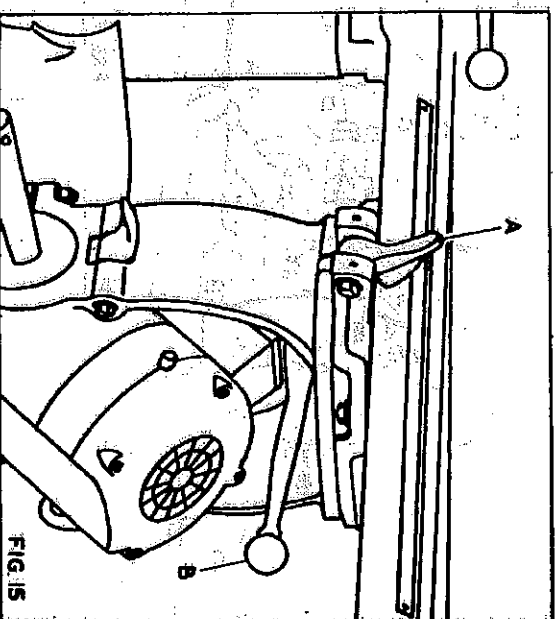
**CARRIAGE AND MOTOR UNIT**

The carriage is mounted on four sealed for life ball bearing rollers grooved to coincide with the circular slideways on the arm. The carriage can be locked in any position along the arm by means of the handwheel on the right of the carriage.

The stirrup is fastened to the carriage by a central pin which enables the motor to swivel through 360°. The principle angles are located by a tapered latch "A" in Fig. 15.

The stirrup can be locked at any angle by the lever "B".

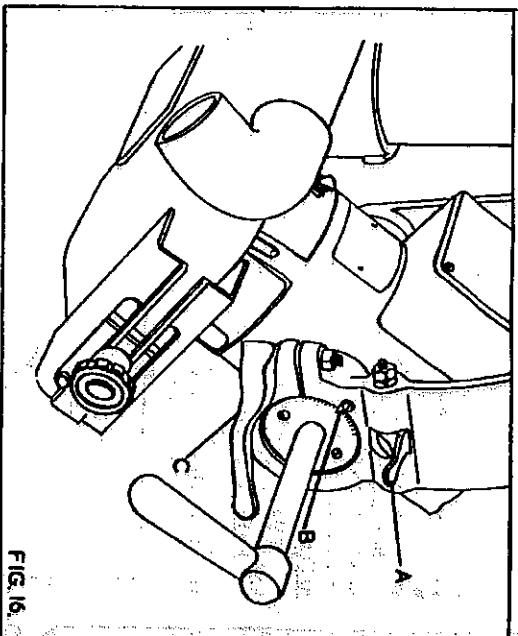

FIG 16.

The motor swivels within the stirrup through 90°. The principle angles are located by a tapered latch "A" in Fig. 16. The angle of cant is clearly shown on a graduated scale by the pointer "B". The motor can be locked at any angle by the locking lever "C".

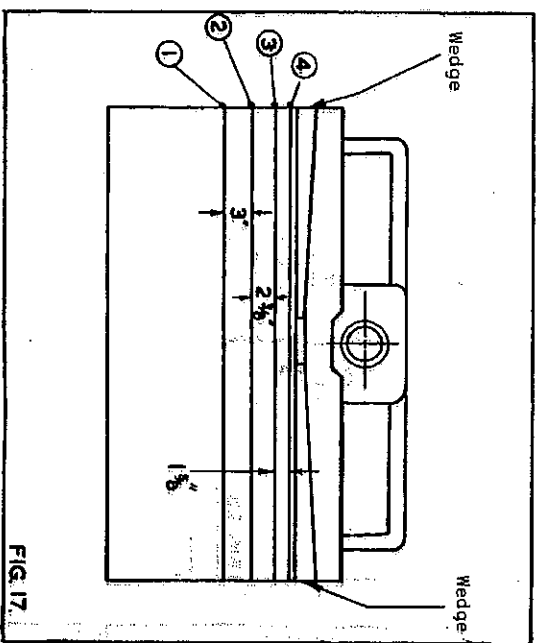

FIG 17.

WOOD TABLE

The wood table is made in such a way to give four fence positions. The fence can easily be moved from one position to another by knocking out the wedges and placing the table strips to suit whichever fence position is required.

POSITION 1.

This enables a maximum timber size of 1 1/2" wide x 5 1/2" deep (320 mm x 140 mm) to be crosscut with the arm at 90°.

POSITION 2.

This enables a maximum timber size of 1 3/4" wide x 1" deep (320 mm x 25 mm) to crosscut with the arm at 90°.

POSITION 3.

This is the most convenient fence position when cutting compound angles with the arm swung to the left of the operator.

There is a rule fitted to each side of the arm for use when ripping. The fence positions, so that these rules show the correct sizes, are as follows:-

1. When ripping from the right hand side of the machine the rule nearest the operator will read correctly with the fence in position 4.
2. When ripping from the left hand side of the machine the rule nearest the operator will read correctly with the fence in position 1.

FITTING SAWBLADES

To fit sawblades the undermentioned procedure should be followed:-

1. Remove the sawguard complete from the motor.
2. Fit long arm hexagon wrench into spindle end and remove the spindle locknut, left hand thread, and remove front saw flange.
3. Fit saw to spindle taking care to ensure the teeth are pointing in the correct direction, also the saw flanges and saw are clean and free from any dirt or sawdust.
4. Replace saw spindle nut and sawguard.

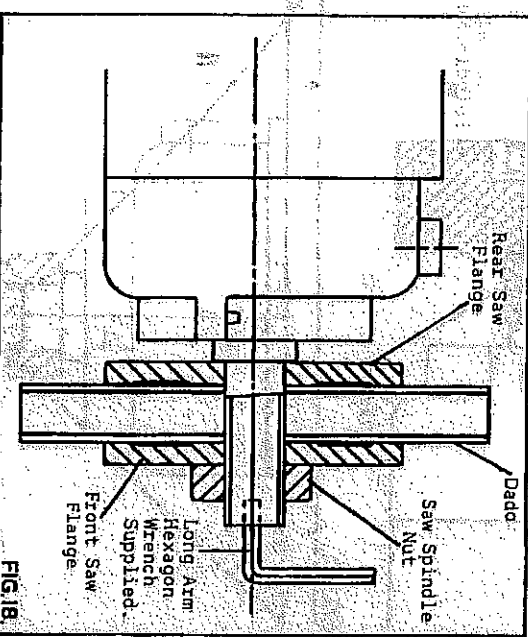

FIG 18.

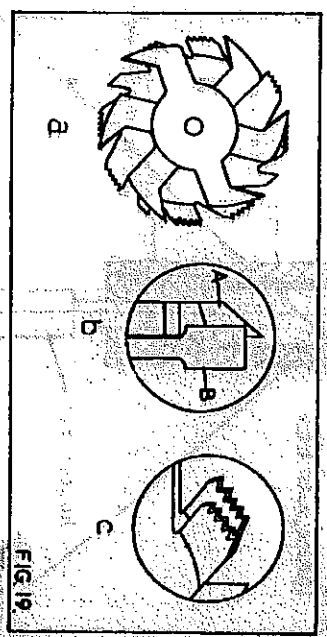

FIG 19.

HOW TO FIT DADO

A dado head is made up of two outside saws and 5 inner cutters. Various combinations of saw and cutters are used to cut grooves from 3/8" to 1" wide (3mm to 25mm). Inner cutters are heavily swaged and must be arranged so that the heavy portion falls in the gullets of the outside saw as shown in Fig. 19 (a), Fig. 19 (b) shows how the saws and cutters overlap. "A" being the saw and "B" being the inside cutter. A 1/4" (6mm) groove is cut by using the two outside saws fitting the ground teeth directly opposite as shown in Fig. 19 (c) in order to allow clearance for the slight set of the saw teeth.

The dado is secured on the spindle between the standard saw flanges as shown in Fig. 18. To fit dado head remove the sawguard and front saw flange, also remove the driving peg from the rear saw flange. Fit the outer saws and required inner cutters onto the spindle and lock in position, then replace sawguard.

HOW TO FIT RIPPING BEARING BRACKET

The adaptor screws into the spindle which is left hand thread. The sawguard and flanges should be removed and the adaptor screwed onto spindle as shown in Fig. 20. The adaptor will take left hand router cutters and boring bits with 1/2" dia. shanks.

HOW TO FIT MOUNTING CUTTERBLOCKS

The cutterblocks are mounted on the end of the spindle as shown in Fig. 21. To mount cutterblocks remove the sawguard and saw flanges. Fit the 1 1/4" (28.5mm) long distance piece supplied onto the spindle then the cutterblock. The special locknut and spacers type Q1, 57, should be used to lock the block in position. The special guard can be supplied for use with these blocks.

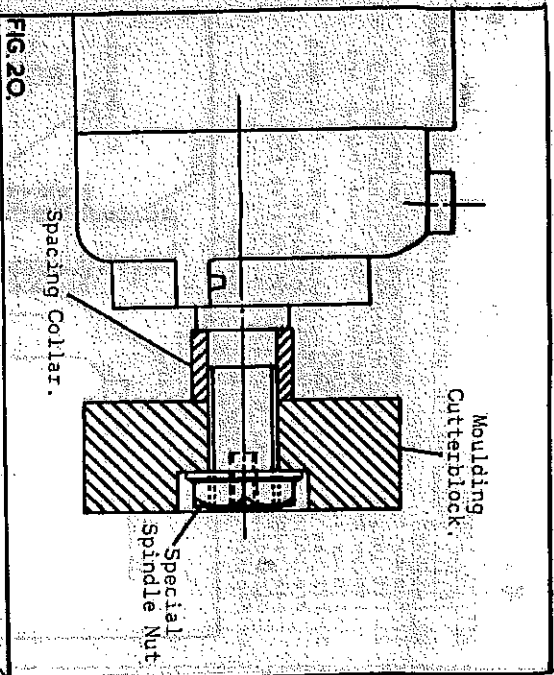

FIG. 20

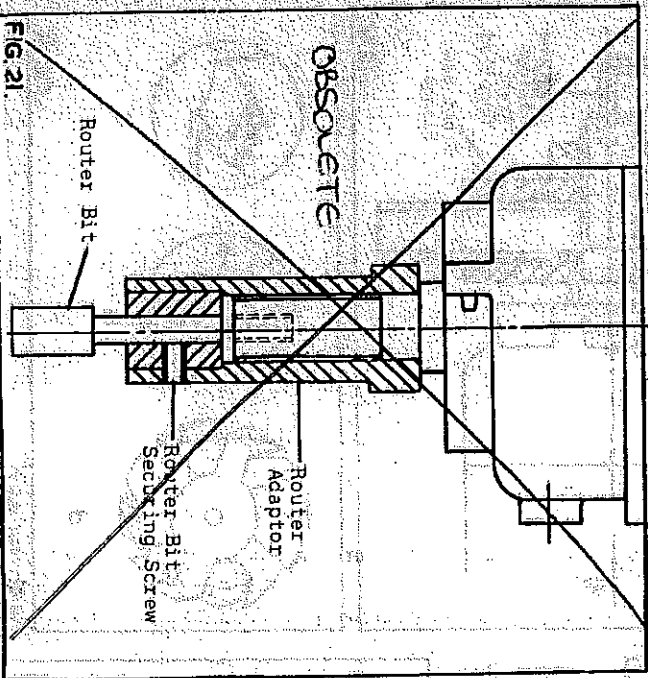

FIG. 21

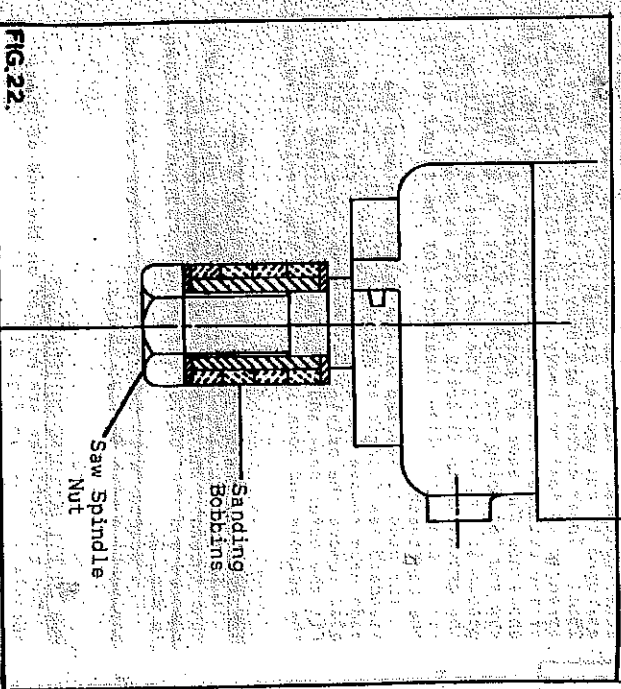

FIG. 22

SAW MAINTENANCE

Efficient operation of a circular saw depends on true running of the saw spindle and the collars being perfectly square on the faces with the axis of the spindle. It must run at the correct peripheral speed to ensure straight cutting. The Burgess radial arm saw embodies all these requirements and provided the saw is maintained in a sharp condition with the teeth correctly sharpened and set, efficient service will be given.

Before putting a new saw to use, it is essential that it is ranged down on the teeth to ensure each tooth is cutting and to maintain true running.

RANGING

Ranging down should be done on a new saw or any saw after the 4th or 5th re-sharpening.

Feed a square edged abrasive block, in wooden holder, lightly against the saw teeth whilst running. The saw should then be removed and the tops of the teeth filed to remove the ranging marks on the points.

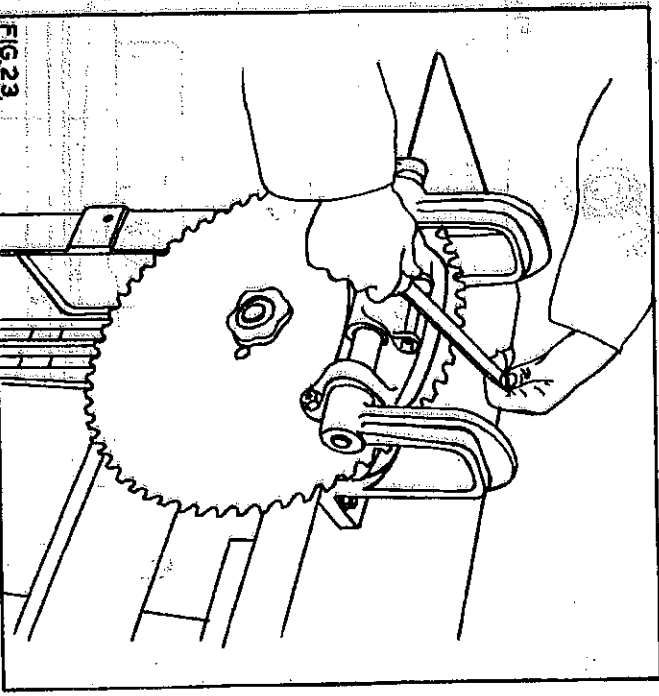

FIG. 23

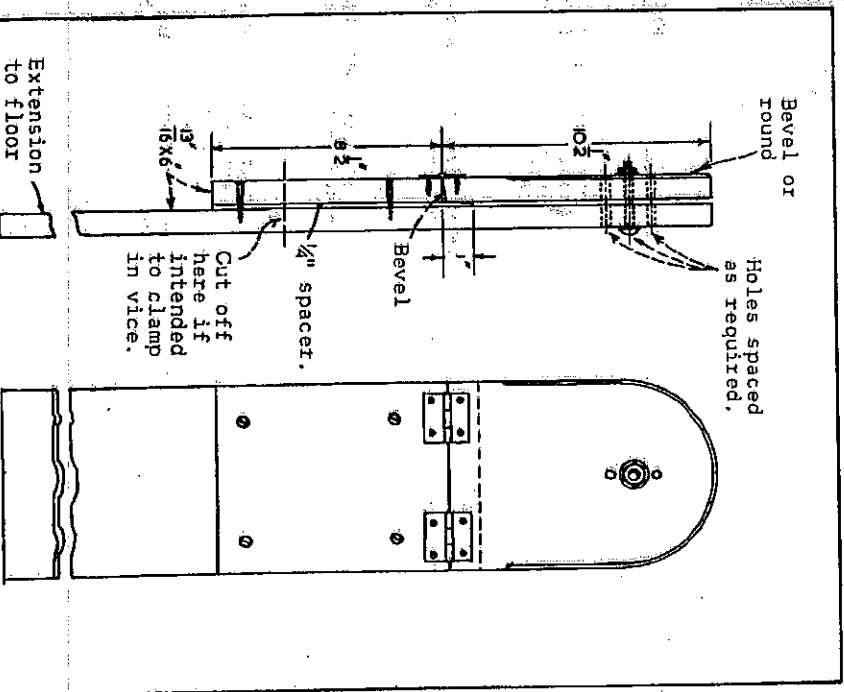
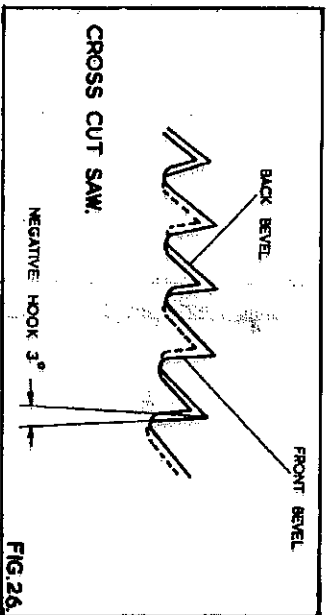
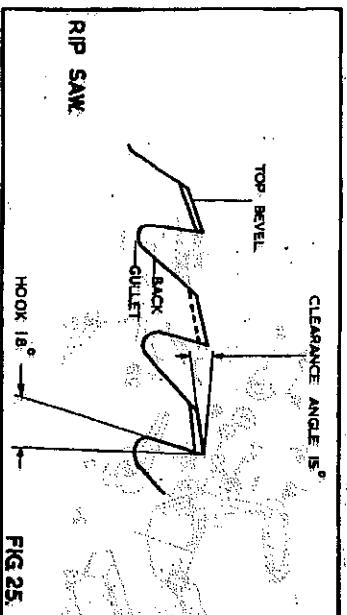

FIG. 24

HOW TO FIT SANDING BOBBINS

The sanding bobbins consist of four rubber sections each $\frac{1}{2}$ " (12.5mm) thick mounted on a sleeve with a steel flange at each end.

Before mounting the bobbins onto the spindle, the sawguard and saw flanges should be removed and the bobbins fit onto spindle as shown in Fig. 22 and locked onto the spindle with the standard arbor nut, left hand thread.



SAW SHARPENING

Do not run a saw when blunt, remove and re-sharpen. Hold a saw rigid in a vice as shown in Fig. 23 or a simple saw vice as shown in Fig. 24 which can be readily made and proceed to sharpen saw.

With rip saw teeth, chisel edges and square faces are needed see Fig. 25. Sharpen by giving each tooth an equal number of strokes with a flat faced saw file with rounded edges. At the same time file the gullet, taking care to keep the gullet well rounded.

With a crosscut saw, saw points are needed with back and front bevels, as shown in Fig. 26.

In the course of repeated filing the teeth loose the original shape and the gullets shallow. To restore the shape of each tooth, essential for satisfactory performance, it is necessary to grind the saw on a saw sharpening machine. These machines are usually of the automatic type and feeds each tooth, giving equal spacing or pitch.

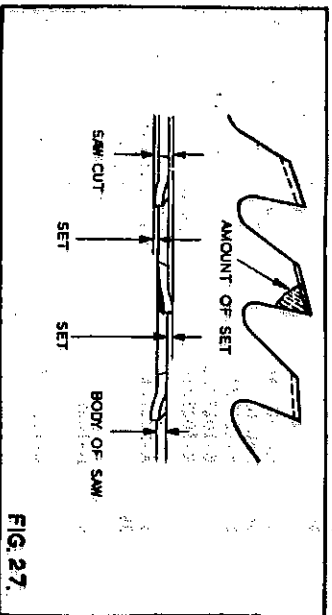

SETTING

The amount of set to the teeth should be sufficient to give clearance to the body of the saw so that there is freedom from friction between saw and timber. It is generally accepted that the teeth are "spring set" i.e. the tips of alternative teeth are bent to the right and left as shown in Fig. 27. For good sawing the amount of set on each side of the saw must be identical otherwise the saw will run to one side. To check the set, cut into a piece of wood of few inches when a small even triangle should be seen, Fig. 28. The exact amount of set each side varies with the timber being cut, usually .010" to .015" (.03mm to .04mm).

For clean cutting, just sufficient set should be allowed to prevent bending and heating. More set is required for wet, woolly timber than for dry, close grained timber and the amount of set is greater for crosscutting saws than those for ripping.

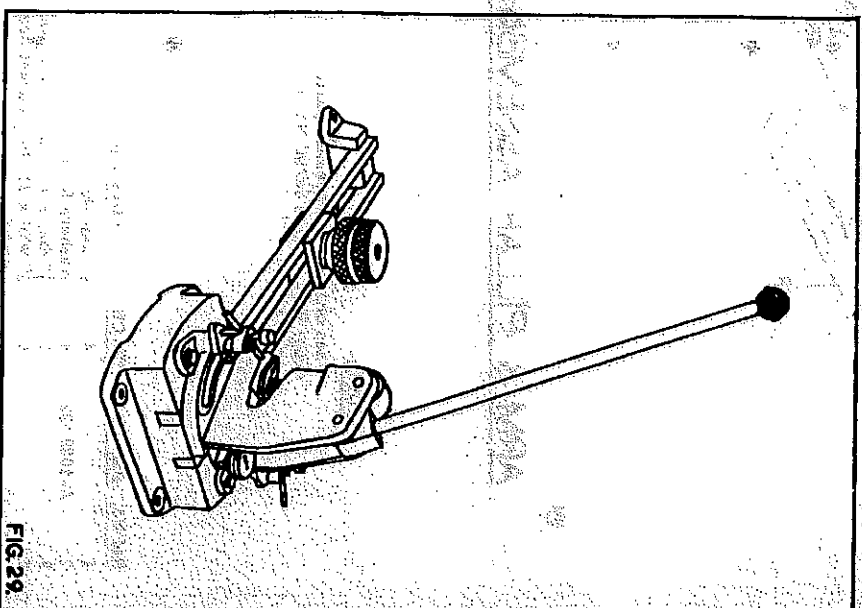

MACHINE SETTING

We can supply a small machine for efficiently setting the teeth as illustrated in Fig. 29 and will deal with saws 8" to 36" (202 mm to 910 mm) diameter. The micrometer dial indicates accurate reading of the amount of set in thousandths of an inch.

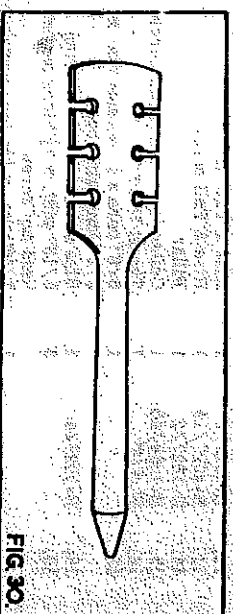

HAND SETTING

Where the number of saws does not warrant a machine being installed the saws are set by hand using a tool shown in Fig. 30. This tool is provided with six notches to take saws 8 to 14 gauge thick. For this process of setting, the saw is securely clamped in a vice.

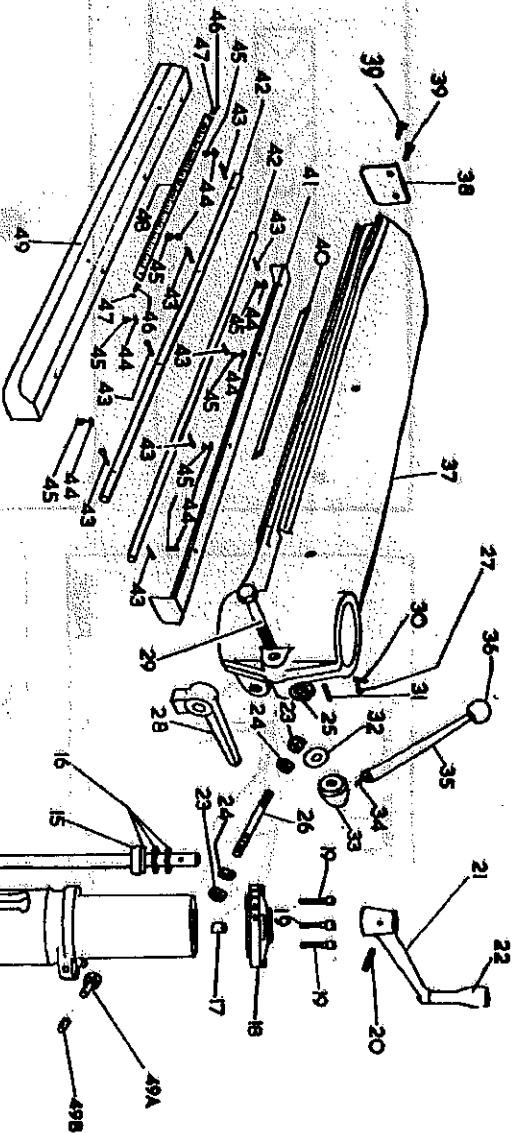

ARM & PILLAR ASSEMBLY

NOTE:-
When ordering replacement parts
quote Part No. and Serial No. of
machine.

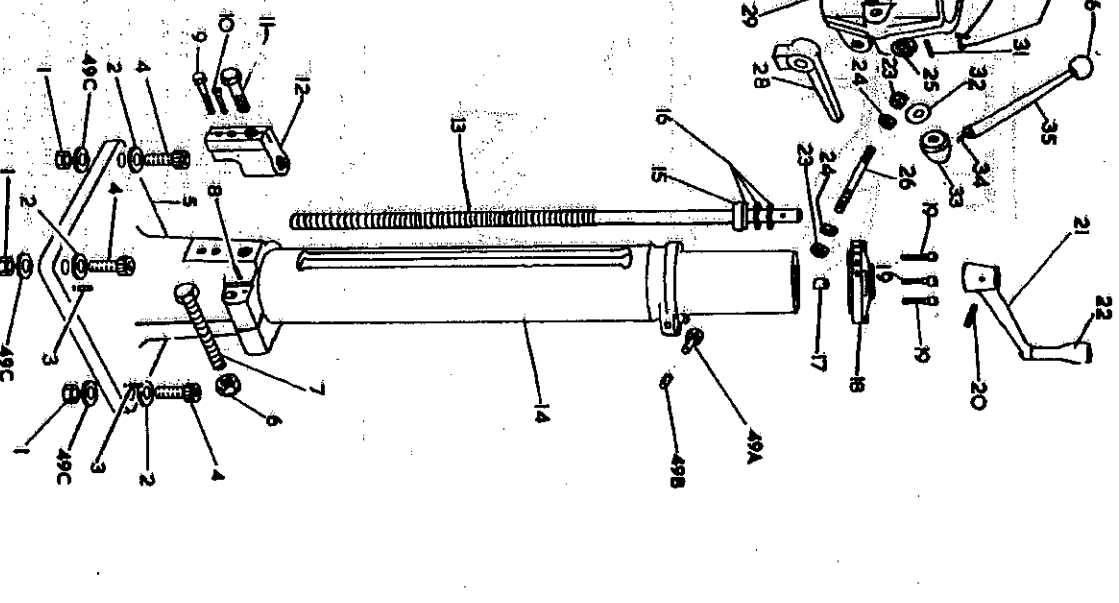

Ref No.	Part No.	No. Off.	Description
1.	A-1027/22	4	½" whit Nut
2.		2	Washers for foot
3.		4	1½" dia. x 1" long fluted dowel.
4.		4	½" whit x 2½" long socket head cap screws
5.	D-1027/3	1	Foot
6.		1	5/8" whit. aerolight nut.
7.		1	5/8" whit. x 5" long hexagon head bolt.
8.		1	1" whit. x ¾" long socket head grub screw
9.		1	¾" whit x 2" long hexagon head bolt.
10.	A-1027/41	1	Rise & fall nut adjusting screw
11.	A-1027/40	1	Rise & fall nut locking screw
12.	B-1027/5	1	Rise & Fall nut
13.	B-1027/15	1	Rise & Fall screw
14.	D-1027/2	1	Pillar
15.	B-1027/40	1	Collar for rise and fall screw
16.	W/5/8"	1	Thrust Race
17.		1	5/8" bore x ¾" outside dia. x 5/8" long olive bush
18.	B-1027/4	1	Rise and fall handle bearing
19.		3	5/16" whit. x 1½" long socket head cap screw
20.		1	3/16" dia. x 1½" long groverlock spring dowel
21.	B-1027/45	1	Rise & Fall handle
22.	Pat No. 4	1	3" plastic handle
23.		2	3/8" whit. thin aerolight nut
24.		2	3/8" whit. locknut.
25.	A-1027/22	1	Spacing washer for arm lock
26.	A-1027/172	1	Pivot pin for pillar latch
27.		1	1" long No. 24 self tapping screw
28.	B-1027/9	1	Arm locking latch
29.	A-1027/155	1	Arm locking bolt
30.	A-1027/58	1	Pointer for arm.
31.	A-1027/48	1	Arm locking handle stop

Ref No.	Part No.	No. Off.	Description
32.		1	½" washer.
33.	A-1027/57	1	Arm locking handle nut
34.		1	3/8" whit. x 1" long socket head grub screw
35.	B-1027/46	1	Arm locking handle
36.	Part No. 28	1	1½" dia. plastic ball. 3/8" whit.
37.	E-1027/1	1	Long Arm (22" x 1" capacity)
	E-1027/36	1	Standard Arm (17" x 1" capacity)
	E-1027/142	1	Special long arm (25" x 1" capacity)
38.	A-1027/6	1	Arm end plate
39.		2	3/8" whit x ¾" long socket head cap screw.
40.	B-1027/37	1	Left Hand arm rule (standard) (0" - 18") (0mm - 457mm)
	B-1027/56	1	Left hand arm rule (metric) (0mm - 466mm)
41.	B-1027/20	1	Shield for rollers (Left hand)
42.	B-1027/39	2	Arm slide rods (standard and long arm)
	B-1027/143	2	Arm slide rods (special long arm)
	CK. 76	8	ZBA Cheese head screw
	A-1027/349	8	Screw (for extra long arm)
		8	¾" washer
45.		8	¾" whit x 3/8" long round head screw
46.	No. 4	4	¾" long self tapping screw
47.		4	1/8" brass washer
48.	B-1027/37	1	Right hand rule (standard) (0" - 14") (0mm - 356mm)
	B-1027/56	1	Right hand rule (metric) (0mm - 355mm)
49.	C-1027/20	1	Shield for rollers (right hand)
49A.	A-1027/13	3	Location bolt.
49B.		3	3/8" whit x 3/8" long socket head grub screw
49C.		4	½" washer

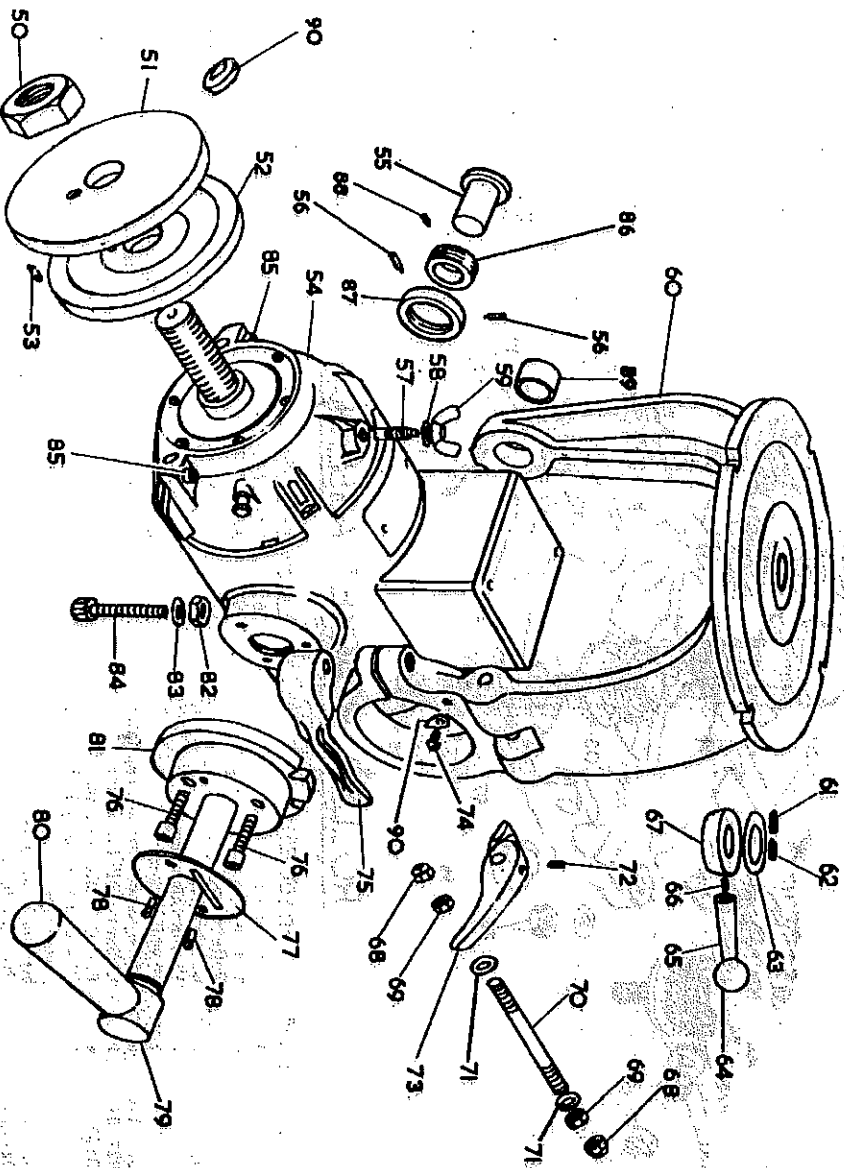

STIRRUP ASSEMBLY

NOTE:-
When ordering replacement parts
quote Part No. and Serial No. of
machine.

Ref. No.	Part No.	No. off	Description	Ref. No.	Part No.	No. off	Description
50	A-1027/21	1	Saw spindle nut (Square)	71	A-1027/170	2	Fibre washer for motor latch
51	B-1027/22	1	Saw flange (fast with 1/2" hole) FOR SQUARE SPINDLE	72		1	1" whit x 3/8" long socket head grub screw
52	B-1027/22	1	Saw flange (fast with 1/2" hole)	73	B-1027/26	1	Motor locating latch
53	A-1027/58	1	Driving peg	74		1	Grub screw
54		1	Brook motor type WS, 105, 5HP 3 phase supply, 3,000 rpm, 50 cycles, 3,600 rpm 60 cycles	75	B-1027/47	1	1" long No. Z4 self tapping screw
55	A-1038/75	1	Motor pivot shaft	76		3	Motor pivot locking handle
56		2	5/16" whit x 3/4" long dogpoint grub screw	77	A-S-127	1	5/16" whit x 1 1/2" long socket head cap screw
57	A-1027/67	1	Saw guard locking stud	78		2	Nameplate
58		1	3/8" washer	79	B-1027/50	1	Pull handle
59		1	3/8" whit wingnut	80	Patt No. 10	1	4" long plastic handle
60	E-1027/8	1	Stirrup	81	B-1027/25	1	Motor locating ring
61		1	1/4" whit x 2 1/2" long socket head grub screw	82		1	3/8" whit nut
62		1	1/4" whit x 5/8" long socket head grub screw	83		1	3/8" brass washer
63	A-1027/55	1	Washer for stirrup pivot screw	84		1	3/8" whit x 2 1/4" long socket head cap screw
64	Patt No. 28	1	1 1/4" dia plastic ball, 3/8" whit	85		2	1/4" whit x 3/8" long socket head cap screw
65	B-1027/46	1	Stirrup locking handle	86	A-1038/82	1	Small motor pivot adjusting bush
66		1	3/8" whit x 1" long socket head grub screw	87	A-1038/83	1	Large motor pivot adjusting bush
67	A-1027/19	1	Stirrup pivot locknut	88		1	5/16" whit x 3/8" long dogpoint grub screw
68		2	1/4" whit thin aeroflight nut	89		1	5/8" L/d x 2 1/2" o/d x 5/8" long olive bush
69		2	1" whit locknut	90	A-1054/58	1	Pointer for arm
70	A-1027/173	1	Pivot pin for motor latch (4 1/2" long)	91	A-1051/6	2	Bush for flange

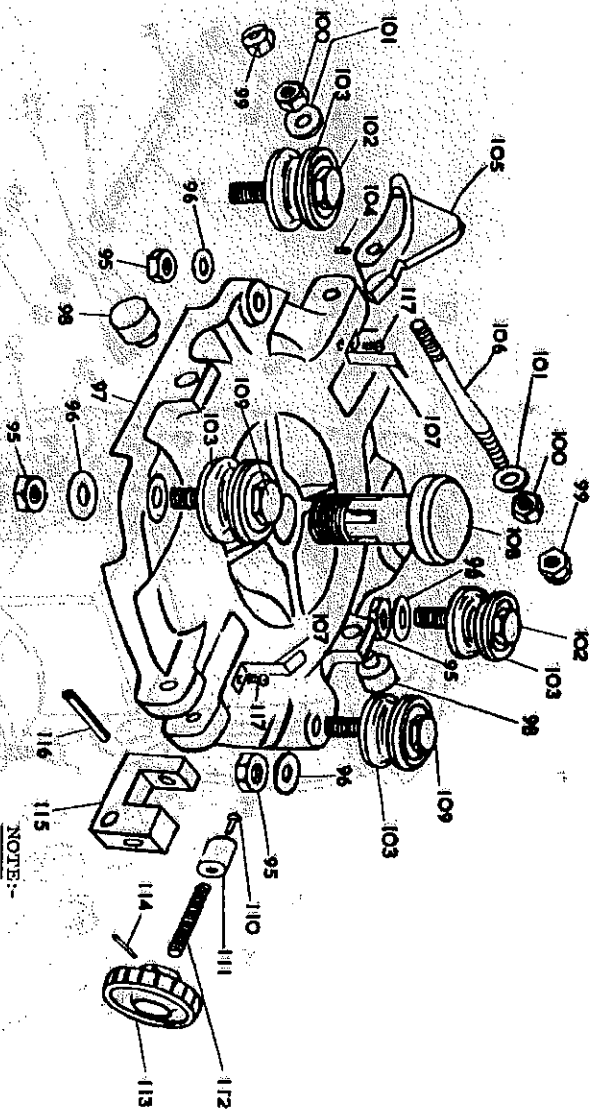

ROLLER BRACKET ASSEMBLY

When ordering replacement parts quote Part No. and Serial No. of machine.

Ref. No.	Part. No.	No. Off.	Description
95		4	3/8" whit nut
96		4	3/8" washer
97	D-1027/7	1	Roller Bracket
98	A-1027/18	2	Rubber Stop
99		2	1" whit thin aerolight nut
100		2	1" whit locknut
101	A-1027/170	2	Fibre washer for stirrup latch
102	A-1027/34	2	Eccentric pin for roller
103	FG 3400	4	F.B.C. roller bearing
104		1	1" whit x 3/8" long socket head gripscrew
105	B-1027/13	1	Stirrup locating latch
106	A-1027/173	1	Pivot pin for stirrup latch
107	B-1027/388	2	Travel pointers

Ref. No.	Part. No.	No. Off.	Description
108	B-1027/38	1	Stirrup pivot screw
109	A-1027/35	2	plain pin for roller
110		1	1/8" dia x 1/2" long fluted rivet
111	A-1027/42	1	End piece for carriage locking screw
112	A-1027/43	1	Carriage locking screw
113	Part. No. 32	1	1 1/8" dia x 3/4" long groverlock spring
114		1	1/8" dia x 3/4" long groverlock spring
115	B-1027/14	1	Travel lock
116		1	3/16" dia x 1 1/2" long groverlock spring
117		2	3/16" whit x 3/8" long round head screw

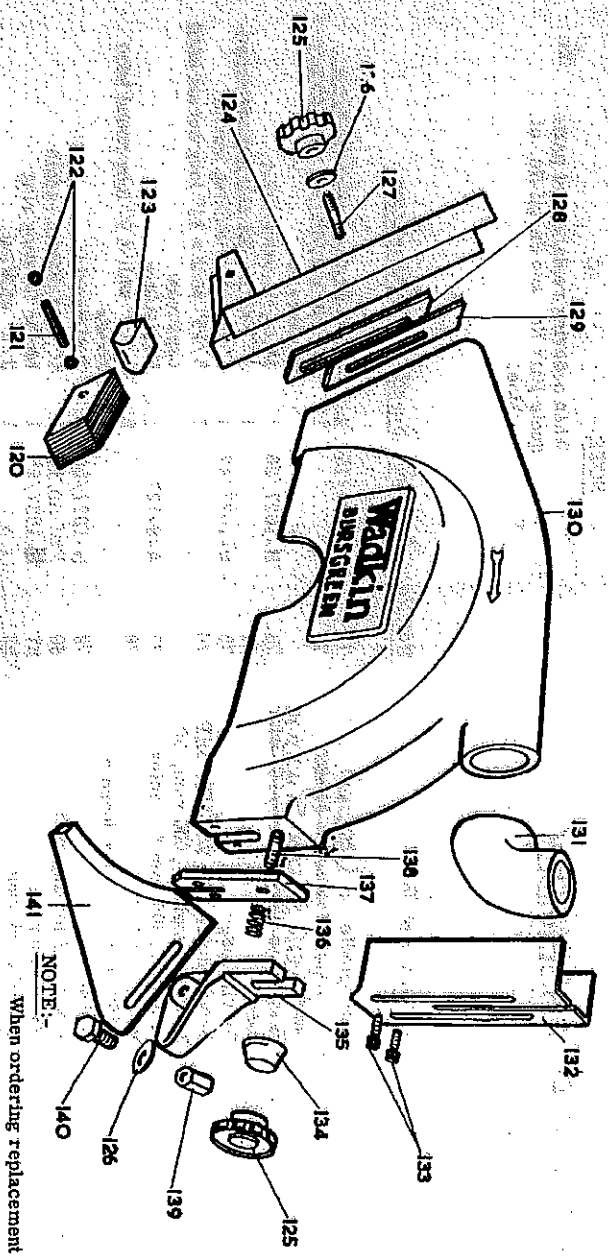

SAWGUARD ASSEMBLY

When ordering replacement parts quote Part No. and Serial No. of machine.

Ref. No.	Part No.	No. Off.	Description
120	A-1027/33	13	Kickback finger
121	A-1027/282	1	Pin for kick back bracket
122	5115-18	2	Safety push on retainer
123	A-1027/59	1	Kick back finger pressure pad
124	B-1051/3	1	Kick back bracket
125	Part. No. 32	2	1 1/4 dia plastic handwheel 3/8" whit T.E.T.
126		2	3/8" washer
127		1	3/8" whit x 1 1/2" long stud
128	A-1051/11	1	Auxiliary cover for kick back bracket
129		1	Cover for kick back bracket
130	D-1051/1	1	Saw guard

Ref. No.	Part No.	No. Off.	Description
131	B-1038/19	1	Chip chime
132	B-1027/17	1	Saw guard vibrator
133		2	5/16" whit x 3/4" long socket head capscrew
134	A-1027/51	1	Riveting knife distance piece
135	B-1027/16	1	Riveting knife bracket
136	A-1027/30	1	Riveting knife spring
137	A-1027/26	1	Riveting knife locating plate
138		1	3/8" whit x 2 1/4" long stud
139	A-1027/29	1	Riveting knife nut
140		1	3/8" whit x 1" long hexagon head bolt
141	B-1027/23	1	Riveting knife

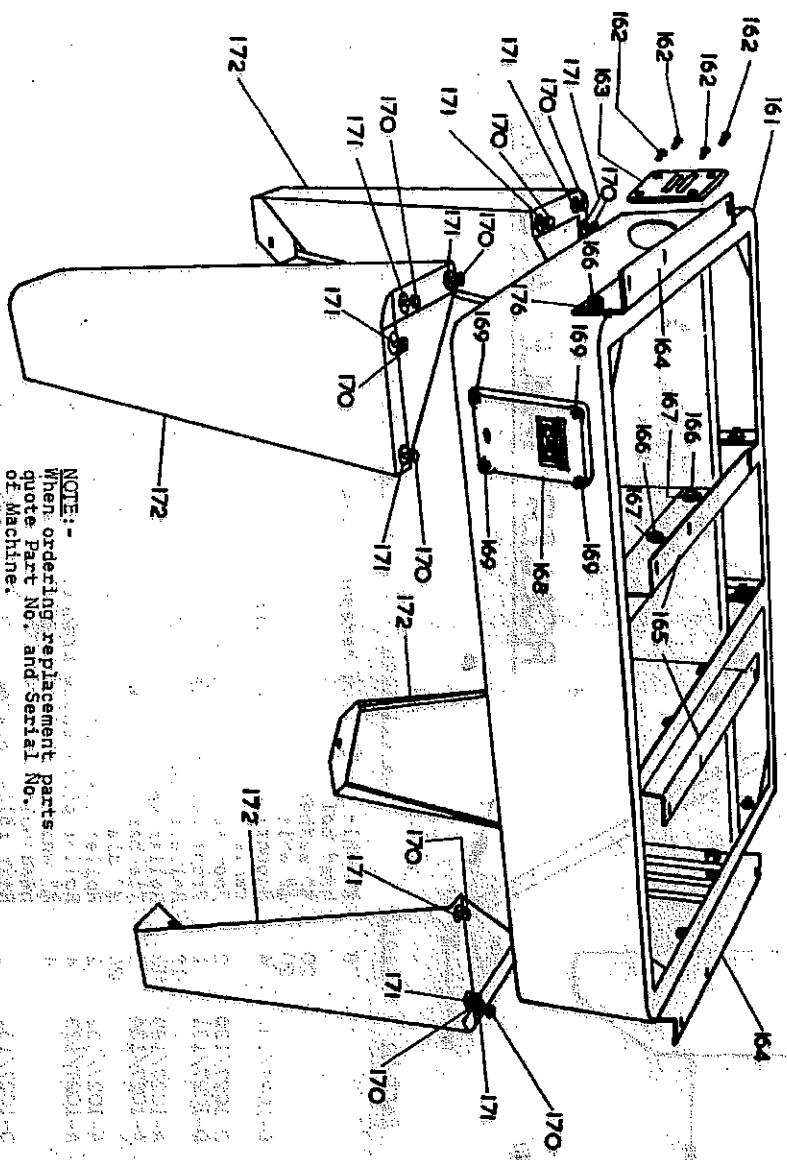
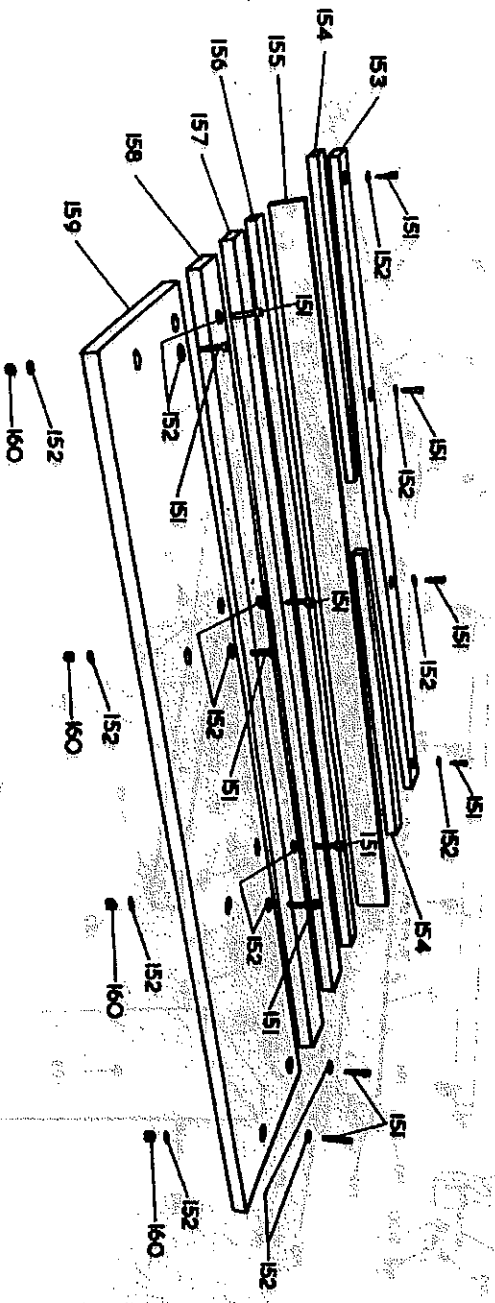

NOTE:-
When ordering replacement parts
quote Part No. and Serial No.
of Machine.

TABLE AND BASE ASSEMBLY.

Ref.No.	Part No.	No. of	Description	Ref.No.	Part No.	No. of	Description
151		12	3/4" Whit x 1" Long cheese head screw	165	B-1027/178	1 each	Inner support bracket for table
152	B-1027/194	24	1/4" washer	166		12	5/16" Whit x 1" Long hexagon head bolt
153	A-1051/R	2	Back support	167		12	5/16" washer
154	A-1027/199	1	Wedge for table	168	84 ADS/FO	1	MEM starter (3phase, 50 cycles)
155	A-1027/199	1	Fence		AT3	1	Brook starter (3 phase 60 cycles)
156	A-1027/199	1	Packing piece for table (1 1/2" wide)	169		4	4" Whit x 3/4" Long cheese head screw
157	A-1027/199	1	Packing piece for table (2 1/2" wide)	170		16	3/4" Whit x 3/4" Long hexagon head bolt
158	A-1027/199	1	Packing piece for table (3" wide)	171		16	3/4" washer
159	B-1051/R	1	Table	172	C-1027/1710CD	4	Leg for base
160	C-1027/171A&B	1	1/4" Whit nut				
161		4	Body for base				
162		4	1/4" Whit x 1/2" Long raised head screw				
163	B-1031/S3	1	Cover plate for base				
164	B-1027/177	1 each	Outer support bracket for table				

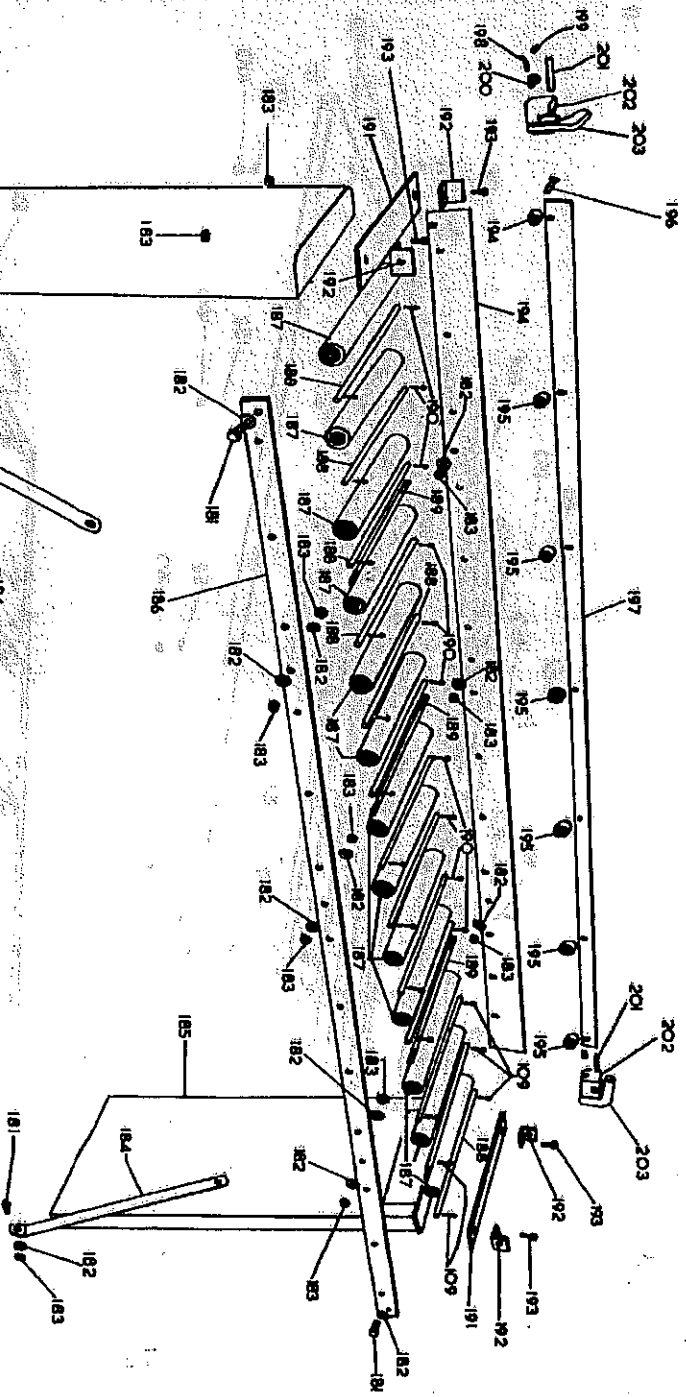

NOTE:-
When ordering replacement parts
quote Part No. and Serial No.
of Machine.

ROLLER TABLE ASSEMBLY.

Ref.No.	Part No.	No.off	Description	Ref.No.	Part No.	No.off	Description
181.		8	$\frac{3}{8}$ " whit. x $\frac{3}{4}$ " long hexagon head bolt.	196.	A-1027/183	7	5/16" whit. x 1 $\frac{1}{2}$ " long cheese head screw.
182.		20	$\frac{3}{8}$ " washer.	197.	A-1027/184	1	Stop bar for roller table to right of saw (standard).
183.		4	$\frac{3}{8}$ " whit. nut.				Stop bar for roller table to left of saw (standard).
184.	D-1027/131	4	Support strut for roller table.				Stop bar for roller table to right of saw (metric).
185.	C-1027/130	2	Foot for roller table.				Stop bar for roller table to left of saw (metric).
186.	D-1027/131	1	Front roller plate.				Pointer for turnover stop.
187.	A-1027/189	13	Rollers ($\frac{1}{2}$ " O.D. x 12" long)	198.	A-1026/54	2	$\frac{1}{4}$ " whit. x $\frac{3}{8}$ " long socket head grub screw.
188.	A-1027/184	13	Roller spindle.				$\frac{3}{8}$ " whit. ball lever screw.
189.	A-1027/132	26	$\frac{1}{8}$ " dia. x 1" long split pin.	199.	B-5-1-B	2	5/16" dia. x 2" long hardened ground dowel.
190.	A-1027/133	4	Roller tie plate.	200.		2	$\frac{3}{8}$ " whit. x $\frac{3}{4}$ " long hexagon head bolt.
191.		2	Roller plate angle bracket.	201.		2	Turnover stop holder.
192.	A-1027/133	4	$\frac{3}{8}$ " whit. x 1" long hexagon head bolt.	202.	A-1027/83	2	Turnover stop.
193.		4	Rear roller plate.	203.	A-1027/84	2	
194.	D-1027/131	1	Stop bar distance plate.				
195.	A-1027/135	7					

NOTE:-
When ordering replacement parts quote Part No. and Serial No. of Machine.

SHAW GUARD ASSEMBLY.

Ref.No.	Part No.	No.off	Description	Ref.No.	Part No.	No.off	Description
221.		2	Wood shoes for shaw guard.	219.	A-1027/175	1	$\frac{3}{4}$ " x $\frac{3}{4}$ " fibrolo.
222.	D-1792/44	1	5/16" whit. x 1 $\frac{1}{2}$ " long hexagon head bolt.	220.	D-1792/65	1	$\frac{3}{4}$ " whit. ball lever screw.
223.		2	5/16" spring washer.	221.	B-5-1-B	3	Column (7 $\frac{1}{2}$ " long).
224.	D-1792/45	4	Shaw guard pressure spring.	222.	A-1027/175	1	$\frac{3}{8}$ " whit. x $\frac{3}{4}$ " long square head bolt.
216.		4	No. 8 x $\frac{3}{4}$ " long black japed round head wood screw.	223.		1	Shaw guard support bracket.
217.		1	5/16" whit. x $\frac{3}{4}$ " long hexagon head bolt.	224.	A-1027/174	1	Bottom Pressure Bar (10" long)
218.	A-1027/176	1	Shaw guard top pressure distance piece.				
219.		1	Top pressure bar (12" long).				
220.		1	$\frac{3}{4}$ " x $\frac{3}{4}$ " fibrolo.				
221.		3	$\frac{3}{4}$ " whit. ball lever screw.				
222.		1	Column (7 $\frac{1}{2}$ " long).				
223.		1	$\frac{3}{8}$ " whit. x $\frac{3}{4}$ " long square head bolt.				
224.		1	Shaw guard support bracket.				
225.		1	Bottom Pressure Bar (10" long)				

APPLICATIONS

There is a place in every woodworking shop for this versatile machine. The saw unit rotates horizontally through 360° and fits to any angle from horizontal to vertical; it can be locked in any position along the arm which swings 45° either way. Thus by simple, quick and positive movements the saw can be arranged to do crosscutting, bevel crosscutting, mitring, compound angle cutting, ripping and bevel ripping to a maximum of 4½" (114 mm) cut. In addition by fitting dado or trenching heads, cutterblocks, moulding blocks etc. an almost unlimited variety of operations are possible - even disc and bobbin sanding can be done with this extremely versatile machine.

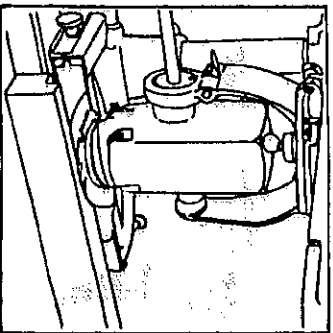

REBATING
WITH DADO HEAD.

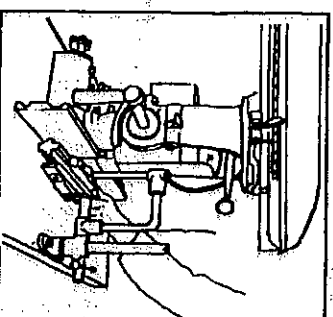

MOULDING WITH
CIRCULAR CUTTERBLOCK.

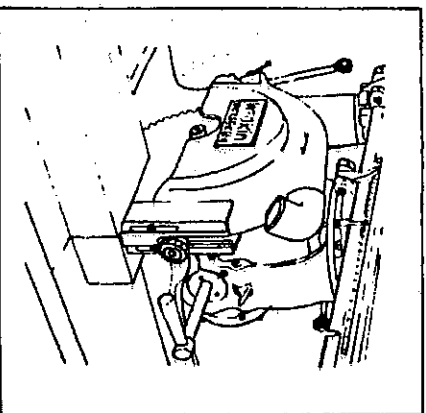

CROSSCUTTING.

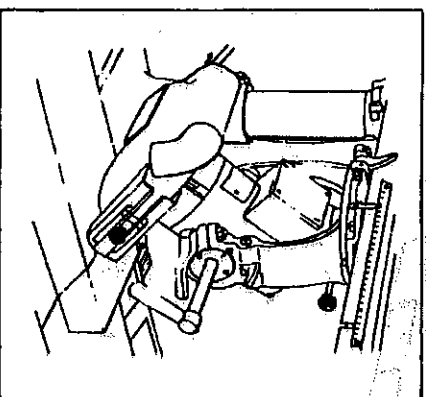

BEVEL CROSSCUTTING.

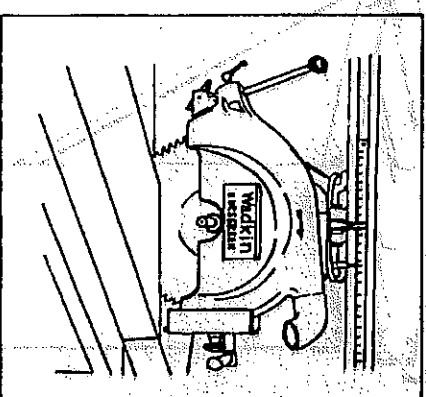

MITRING.

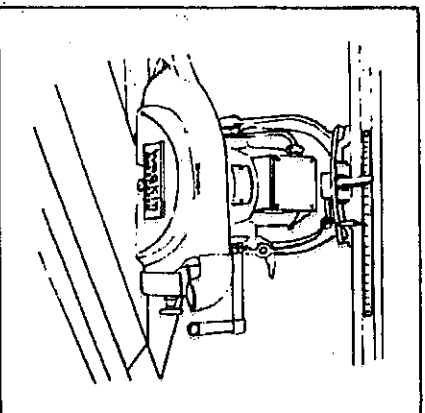

COMPOUND MITRING.

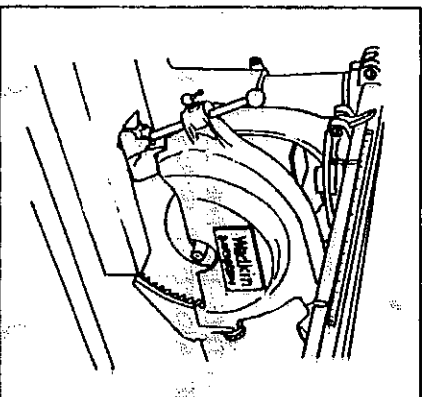

STRAIGHT RIPPING.

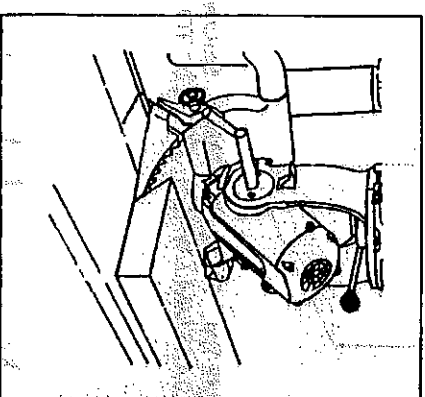

BEVEL RIPPING.

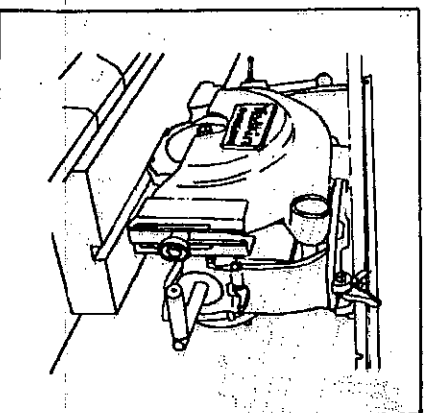

PLOUGHING WITH DADO HEAD.

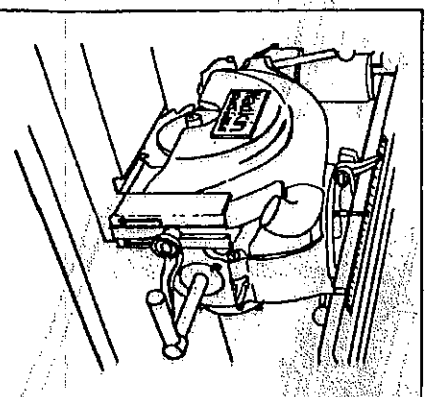

GROOVING WITH DADO HEAD.

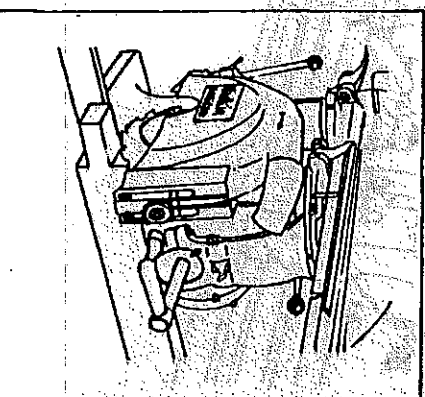

TENONING WITH DADO HEAD.

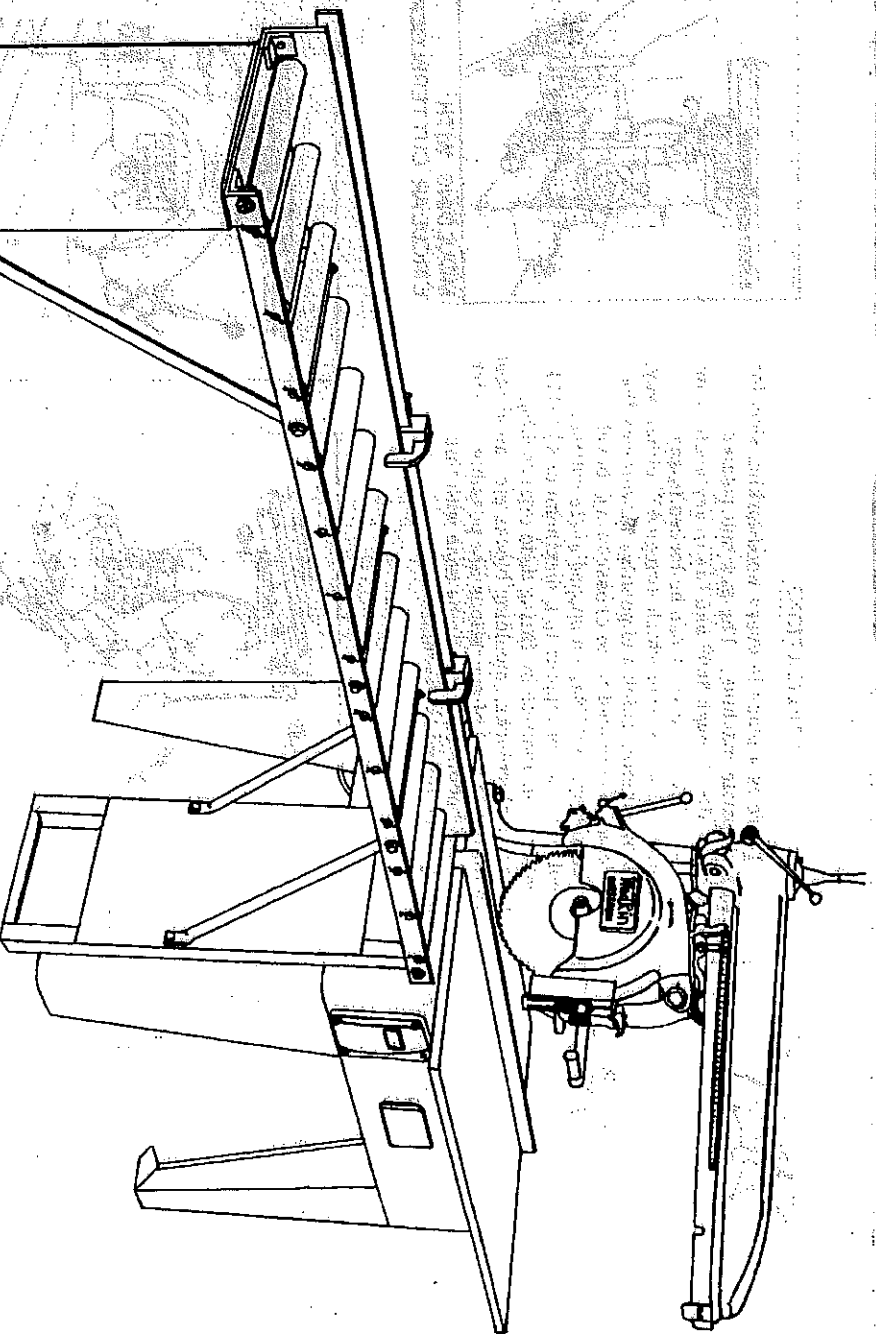

METAL ROLLER TABLE SHOWN FITTED TO THE LEFT OF THE SAW TO GIVE A MAX^m OF 8 FT (2438 MM) WHEN FITTED TO THE RIGHT IT GIVES A MAX^m OF 9 FT (2743 MM).

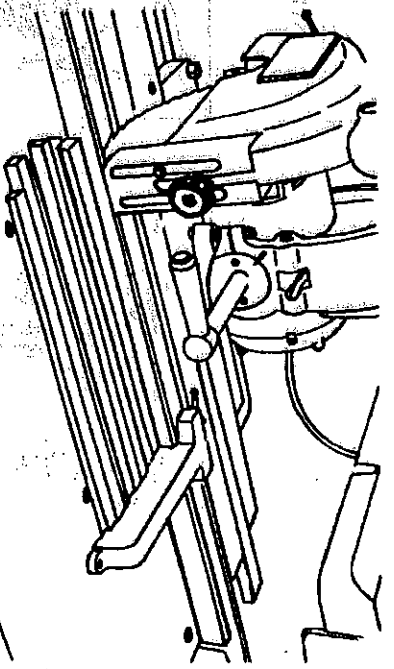
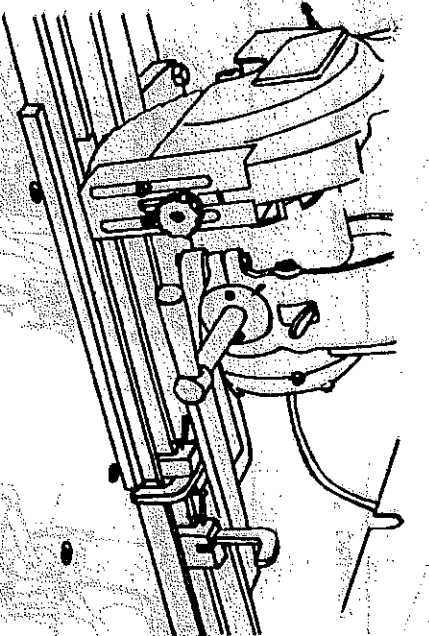

CROSSCUTTING USING TURNOVER STOP & METAL FENCE FOR REPETITION WORK.

MULTIPLE CROSSCUTTING USING METAL FENCE AND SPECIAL STOP WHICH CAN BE READILY FITTED TO THE STOP BAR.

WORKFIELD

THE ILLUSTRATED JOINTS CAN BE READILY DONE ON THIS MACHINE, SOME MAY REQUIRE SIMPLE JIGS.

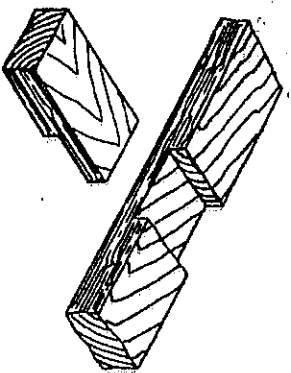

TEE HALF LAP

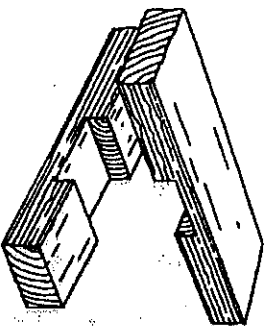

MIDDLE HALF LAP

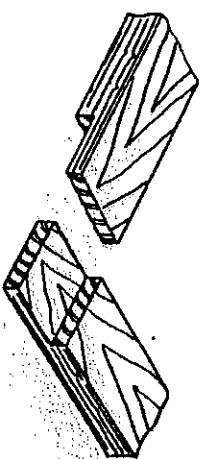

END HALF LAP

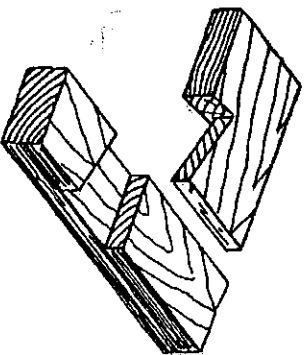

DOVETAIL HALF LAP
(ONE SIDE ONLY)

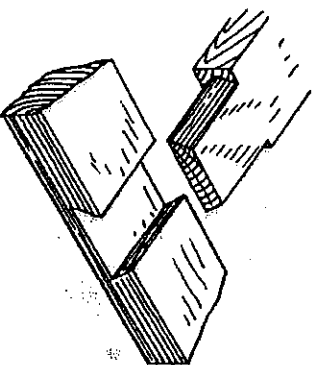

DOVETAIL HALF LAP

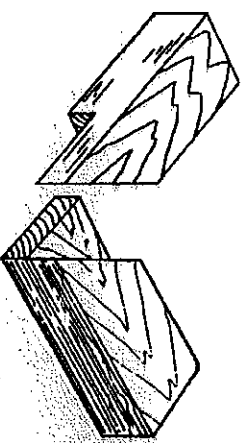

MITRED FACE WITH HALF LAP

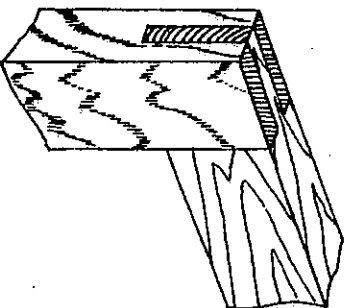

OPEN MORTISE & TENON

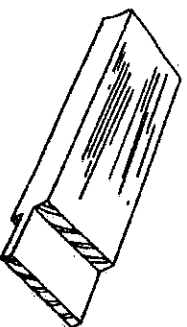

TENONS.

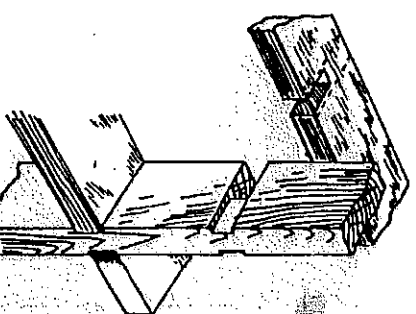

LAPPED JOINT WITH GROOVE
(USEFUL FOR SHELVING)

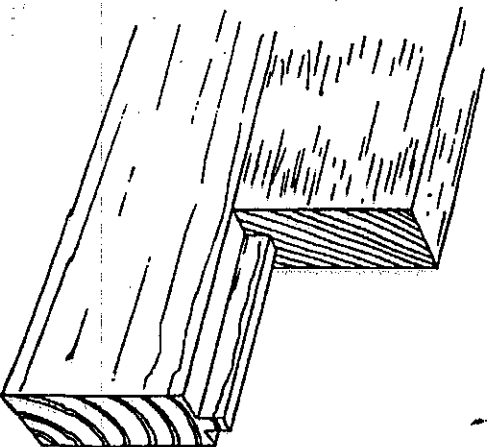

TONGUE & GROOVE

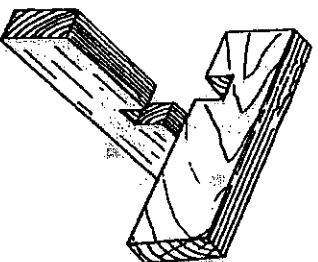

MIDDLE HALF LAP

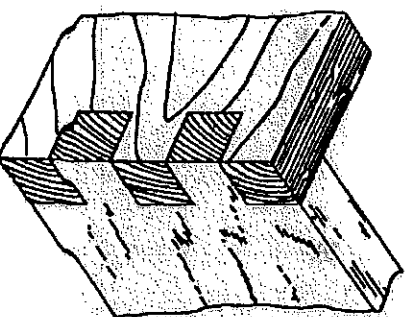

BOX JOINT