

BOOK No.

Modifications are made to these books from time to time and it is important therefore that only the book sent with the machine should be used as a working manual

PLEASE INSERT SERIAL NUMBER OF MACHINE

INSTRUCTION MANUAL FOR

350 & 400BRA

Universal & Semi Universal Radial Arm Saws

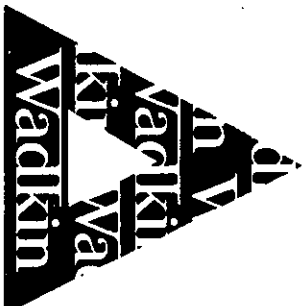

HEALTH & SAFETY

SAFETY OF WOODWORKING MACHINES

Woodworking machines can be dangerous if improperly used. The wide range of work of which they are capable, requires adequate safeguarding arrangements against possible hazards.

Many injuries to machinists are caused by carelessness or failure to use the guards provided or to adjust them correctly.

WADKIN PLC, supply machinery designed for maximum safety which they believe, as a result of thorough testing, minimizes the risks inevitable in their use. It is the user's responsibility to see that the following rules are complied with to ensure safety at work:

1. The operation of the machine should conform to the requirements of the Woodworking Machines Regulations 1974. All guards should be used and adjusted correctly.
2. Safe methods of working only should be adopted as given in the Health and Safety Work Booklet No.41, "Safety in the Use of Woodworking Machines", (obtainable from Her Majesty's Stationery Office) and as advised by Wadkin Ltd.
3. Only personnel trained in the safe use of a machine should operate it.
4. Before making adjustments or clearing chips, etc., the machine should be stopped and all movement should have ceased.
5. All tools and cutters must be securely fixed and the speed selected must be appropriate for the tooling.

SAFETY IS OUR WATCHWORD BUT THE USER MUST COMPLY WITH THE ABOVE RULES IN HIS OWN INTEREST. WE WOULD BE PLEASED TO ADVISE ON THE SAFE USE OF OUR PRODUCTS.

000

350 & 400 BRA Universal & Semi Universal Radial Arm Saws

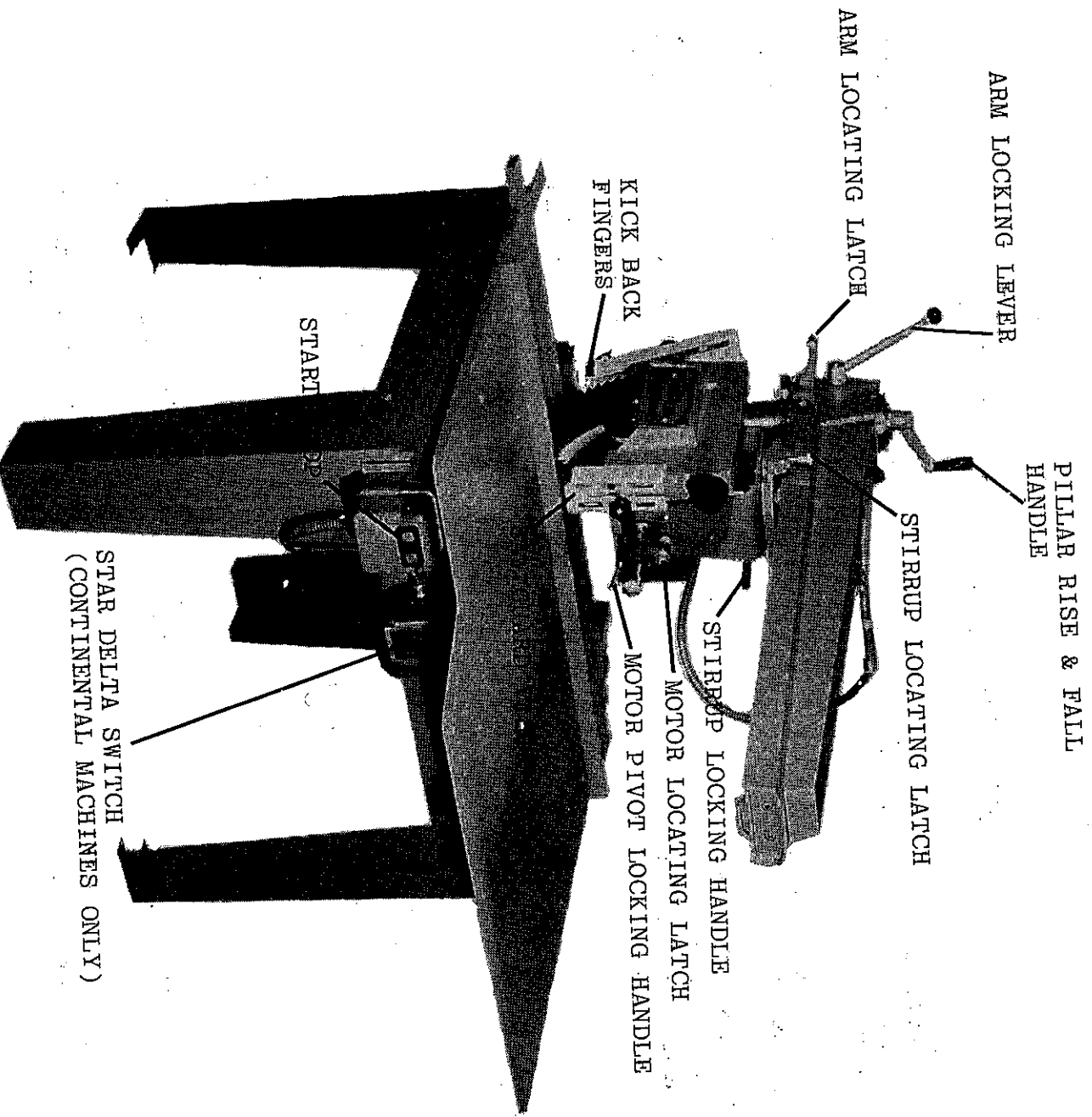

NOTE: MACHINE SHOWN ABOVE IS FITTED WITH LONG ARM (EXTRA)

SPECIFICATION. UNIVERSAL 350 BRA.

Maximum diameter of saw.	350mm	350mm
Maximum saw projection.	108mm	4 $\frac{1}{2}$ "
Width will crosscut with.	415 x 108mm	16 $\frac{1}{4}$ " x 4 $\frac{1}{4}$ "
Standard arm at 90°	480 x 25mm	18 $\frac{3}{4}$ " x 1"
Width will crosscut with.	227 x 108mm	8 $\frac{3}{4}$ " x 4 $\frac{1}{4}$ "
Standard at 45°	288 x 25mm	11 $\frac{1}{4}$ " x 1"

To order, machine can be fitted with longer arm to give additional 265mm (10. 3/8") length of cut.

Maximum width of grooving head.	50.8mm	2"
Maximum ripping capacity.	680mm	26 $\frac{3}{4}$ "
Height of work table.	805mm	31 $\frac{1}{2}$ "
Diameter of saw spindle	30mm	30mm
Power of motor.	3Kw.	4HP.

(4.5Kw optional) (6HP optional)

Speed of motor, 50 hertz.	3000rev/min.	
Speed of motor, 60 hertz.	3600rev/min.	
Maximum overall height.	1790mm	70 $\frac{1}{2}$ "
Floor space.	1170 x 1600mm	46 x 63"
Net weight (Approx.)	210Kg.	462 lb.
Gross weight (Approx.)	316Kg.	695 lb.
Shipping dimensions (Approx.)	0.99 cu.m.	35 cu.ft.

SPECIFICATION. SEMI UNIVERSAL 350 BRA.

Maximum diameter of saw.	350mm	350mm
Maximum saw projection.	108mm	4 $\frac{1}{2}$ "
Width will crosscut with.	440 x 108mm	17 $\frac{1}{4}$ " x 4 $\frac{1}{4}$ "
Standard arm at 90°	490 x 25mm	19 $\frac{1}{4}$ " x 1"
Width will crosscut with.	244 x 108mm	9 $\frac{5}{8}$ " x 4 $\frac{1}{4}$ "
Standard arm at 45°	309 x 25mm	12" x 1"

To order, machine can be fitted with longer arm to give additional 265mm (10. 3/8") length of cut.

Maximum width of grooving head.	50.8mm	2"
Height of work table.	805mm	31 $\frac{1}{2}$ "
Diameter of saw spindle.	30mm	30mm
Power of motor.	3Kw	4HP

(4.5Kw optional) (6HP optional)

Speed of motor, 50 hertz.	3000rev/min.	
Speed of motor, 60 hertz.	3600rev/min.	
Maximum overall height.	1790mm	70 $\frac{1}{2}$ "
Floor space.	1170 x 1600mm	46 x 63"
Net weight (Approx.)	210Kg.	462 lb.
Gross weight (Approx.)	316Kg.	695 lb.
Shipping dimensions. (Approx.)	0.99 cu.m.	35 cu.ft.

SPECIFICATION. SEMI UNIVERSAL 400 BBA.

Maximum diameter of saw.	400mm	400mm
Maximum saw projection.	133mm	5.1/8"
Width will crosscut with.	133mm	15 1/4 x 5.1/8"
Standard arm at 90°.	450 x 25mm	17.5/8" x 1"
Width will crosscut with.	110 x 133mm	4 1/2 x 5.1/8"
Standard arm at 45°.	260 x 25mm	10 1/4 x 1"

To order, machine can be fitted with longer arm to give additional 265mm (10.3/8") length of cut.

Maximum width of grooving.	50.8mm	2"
Maximum ripping capacity.	760mm	29 3/4"
Height of work table.	805mm	31 1/2"
Diameter of saw spindle.	30mm	30mm
Power of motor.	4.5Kw.	6HP.
Speed of motor, 50 hertz.	3000rev/min.	
Speed of motor, 60 hertz.	3600rev/min.	
Maximum overall height.	1790mm	70 1/2"
Floor space.	1170 x 1650mm	46 x 63"
Net weight (Approx.)	240Kg.	528 lb.
Gross weight (Approx.)	346Kg.	761 lb.
Shipping dimensions (Approx.)	0.99 cu.m.	35 cu.ft.

SPECIFICATION. SEMI UNIVERSAL 400 BBA.

Maximum diameter of saw.	400mm	400mm
Maximum saw projection.	133mm	5.1/8"
Width will crosscut with.	133mm	16 1/4 x 5.1/8"
Standard arm at 90°.	465 x 25mm	18 1/4 x 1"
Width will crosscut with.	130 x 133mm	5 x 5.1/8"
Standard arm at 45°.	280 x 25mm	11 x 1"

To order, machine can be fitted with longer arm to give additional 265mm (10.3/8") length of cut.

Maximum width of grooving head.	50.8mm	2"
Height of work table.	805mm	31 1/2"
Diameter of saw spindle.	30mm	30mm
Power of motor.	4.5Kw.	6HP.
Speed of motor, 50 hertz.	3000rev/min.	
Speed of motor, 60 hertz.	3600rev/min.	
Maximum overall height.	1790mm	70 1/2"
Floor space.	1170 x 1600mm	46 x 63"
Net weight (Approx.)	240Kg.	528 lb.
Gross weight (Approx.)	346Kg.	761 lb.
Shipping dimensions (Approx.)	0.99 cu.m.	35 cu.ft.

SPECIFICATION. UNIVERSAL 350 BRA.

Maximum diameter of saw.	350mm	350mm
Maximum saw projection.	108mm	4 $\frac{1}{2}$ "
Width will crosscut with.	415 x 108mm	16 $\frac{1}{4}$ " x 4 $\frac{1}{4}$ "
Standard arm at 90	480 x 25mm	18 $\frac{3}{4}$ " x 1"
Width will crosscut with.	227 x 108mm	8 $\frac{3}{4}$ " x 4 $\frac{1}{4}$ "
Standard at 45.	288 x 25mm	11 $\frac{1}{4}$ " x 1"

To order, machine can be fitted with longer arm to give additional 265mm (10. 3/8") length of cut.

Maximum width of grooving head.	50.8mm	2"
Maximum ripping capacity.	680mm	26 $\frac{3}{4}$ "
Height of work table.	805mm	31 $\frac{1}{2}$ "
Diameter of saw spindle	30mm	30mm
Power of motor.	3KW.	4HP.

(4.5KW optional) (6HP optional)

Speed of motor, 50 hertz.	3000rev/min.	
Speed of motor, 60 hertz.	3600rev/min.	
Maximum overall height.	1790mm	70 $\frac{1}{2}$ "
Floor space.	1170 x 1600mm	46 x 63"
Net weight (Approx.)	210Kg.	462 lb.
Gross weight (Approx.)	316Kg.	695 lb.
Shipping dimensions (Approx.)	0.99 cu.m.	35 cu.ft.

SPECIFICATION. SEMI UNIVERSAL 350 BRA.

Maximum diameter of saw.	350mm	350mm
Maximum saw projection.	108mm	4 $\frac{1}{2}$ "
Width will crosscut with.	440 x 108mm	17 $\frac{1}{4}$ x 4 $\frac{1}{4}$ "
Standard arm at 90.	490 x 25mm	19 $\frac{1}{4}$ x 1"
Width will crosscut with.	244 x 108mm	9 $\frac{5}{8}$ x 4 $\frac{1}{4}$ "
Standard arm at 45.	309 x 25mm	12" x 1"

To order, machine can be fitted with longer arm to give additional 265mm (10. 3/8") length of cut.

Maximum width of grooving head.	50.8mm	2"
Height of work table.	805mm	31 $\frac{1}{2}$ "
Diameter of saw spindle.	30mm	30mm
Power of motor.	3KW	4HP

(4.5KW optional) (6HP optional)

Speed of motor, 50 hertz.	3000rev/min.	
Speed of motor, 60 hertz.	3600rev/min.	
Maximum overall height.	1790mm	70 $\frac{1}{2}$ "
Floor space.	1170 x 1600mm	46 x 63"
Net weight (Approx.)	210Kg.	462 lb.
Gross weight (Approx.)	316Kg.	695 lb.
Shipping dimensions. (Approx.)	0.99 cu.m.	35 cu.ft.

SPECIFICATION. UNIVERSAL 400 BRA.

Maximum diameter of saw.	400mm	400mm
Maximum saw projection.	133mm	5.1/8"
Width will crosscut with.	133mm	15 1/4 x 5.1/8"
Standard arm at 90°.	450 x 25mm	17.5/8" x 1"
Width will crosscut with.	110 x 133mm	4 1/4 x 5.1/8"
Standard arm at 45°.	260 x 25mm	10 1/4 x 1"

To order, machine can be fitted with longer arm to give additional 265mm (10.3/8") length of cut.

Maximum width of grooving.	50.8mm	2"
Maximum ripping capacity.	760mm	29 3/4"
Height of work table.	805mm	31 1/2"
Diameter of saw spindle.	30mm	30mm
Power of motor.	4.5Kw.	6HP.
Speed of motor, 50 hertz.	3000rev/min.	
Speed of motor, 60 hertz.	3600rev/min.	
Maximum overall height.	1790mm	70 1/2"
Floor space.	1170 x 1650mm	46 x 63"
Net weight (Approx.)	240Kg.	528 lb.
Gross weight (Approx.)	346Kg.	761 lb.
Shipping dimensions (Approx.)	0.99 cu.m.	35 cu.ft.

SPECIFICATION. SEMI UNIVERSAL 400 BRA.

Maximum diameter of saw.	400mm	400mm
Maximum saw projection.	133mm	5.1/8"
Width will crosscut with.	133mm	16 1/4 x 5.1/8"
Standard arm at 90°.	465 x 25mm	18 1/4 x 1"
Width will crosscut with.	130 x 133mm	5 x 5.1/8"
Standard arm at 45°.	280 x 25mm	11 x 1"

To order, machine can be fitted with longer arm to give additional 265mm (10.3/8") length of cut.

Maximum width of grooving head.	50.8mm	2"
Height of work table.	805mm	31 1/2"
Diameter of saw spindle.	30mm	30mm
Power of motor.	4.5Kw.	6HP.
Speed of motor, 50 hertz.	3000rev/min.	
Speed of motor, 60 hertz.	3600rev/min.	
Maximum overall height.	1790mm	70 1/2"
Floor space.	1170 x 1600mm	46 x 63"
Net weight (Approx.)	240Kg.	528 lb.
Gross weight (Approx.)	346Kg.	761 lb.
Shipping dimensions (Approx.)	0.99 cu.m.	35 cu.ft.

APPROVED LUBRICANTS

Application	Approved Lubricant					
	Castrol	B. P.	Shell	Esso	Texaco/ Caltex	Wadkin
Worm Boxes	Alpha 617	Energol CS425	Vitrea 75	Pen-O-Led E. P.3	Regal Oil J	L. 2.
General Lubrication	Magna ED	Energol HP. 20	Vitrea 33	Esstic 50	Ursa Oil P. 20	L. 4.
Pneumatic Lubricators	Hyspin AWS 32	Energol HL 65	Tellus 27	Nuto H 44	Rando Oil HDA	
Grease	Spheerol AP. 3	Energrease LS. 3	Alvania 3	Beacon 3 Starfak Premium 3	Regal	L. 6.
Brake Cables	Brake cable grease	Energrease L21M	Alvania 3	Multi-purpose grease H		

INSTALLATION

Remove protective coating from bright parts by applying a cloth soaked in paraffin, turpentine or some other solvent.

When the machine is cased for export the carriage and motor unit are removed from the arm, the arm is removed from the pillar, the pillar and foot assembly is removed from the base along with the legs. All these items are packed individually in the case. Remove and assemble as shown in Fig. 1.

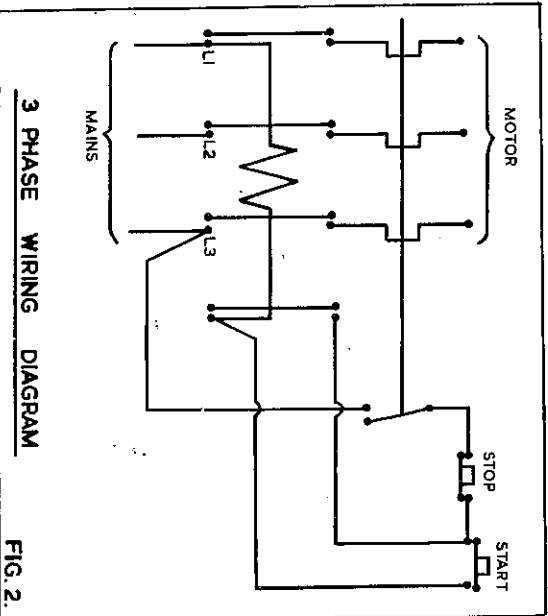

FIG. 2.

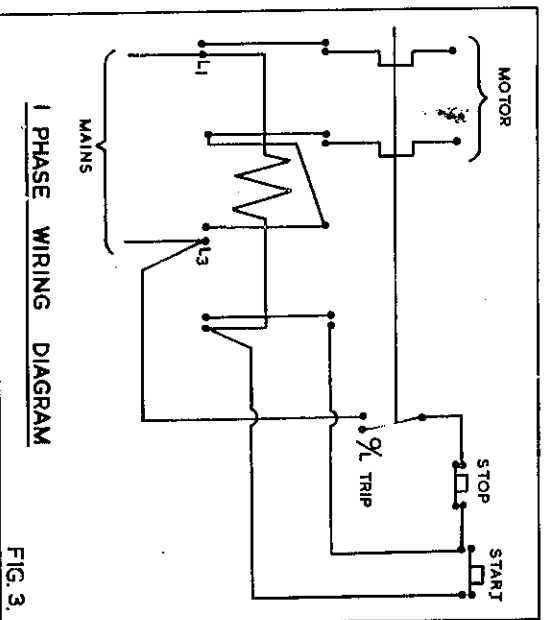

FIG. 3.

WIRING DETAILS

The motor and control gear have been wired in before despatch. All that is required is to connect the power supply to the starter.

Points to note when connecting to power supply :-

1. Check the voltage, phase and frequency correspond to those on the motor plate, also the correct coils and heaters are fitted to the starter.
2. It is important that the correct cable is used to give the correct voltage to the starter, as running on low voltage will damage the motor.
3. Check the main line fuses are of the correct capacity. See list below.
4. Connect the line leads to the appropriate terminals. See Fig 2 for 3 phase supply and Fig. 3 for 1 phase supply.
5. Check all connections are sound.
6. Check the rotation of the motor for correct direction. If this is incorrect for 3 phase supply reverse any two of the line lead connections.

VOLTAGE	PHASE	H. P.	S. W. G. TINNED COPPER WIRE	AMPS
220	3	3	21	29
380/420	3	3	24	17
550	3	3 & 5	23	20
220	3	5	17	65
380/420	3	5	22	24
200/220	1	3	17	65
230/250	1	3	18	45

LUBRICATION

It is advisable to keep all bright parts covered with a thin film of oil to prevent rusting.

The slide rods and rollers should also be kept clear of any sawdust and chippings for ease of operation.

TYPE OF OIL RECOMMENDED POWER EM. 125
TYPE OF GREASE RECOMMENDED SHELL ALYANIA 3.

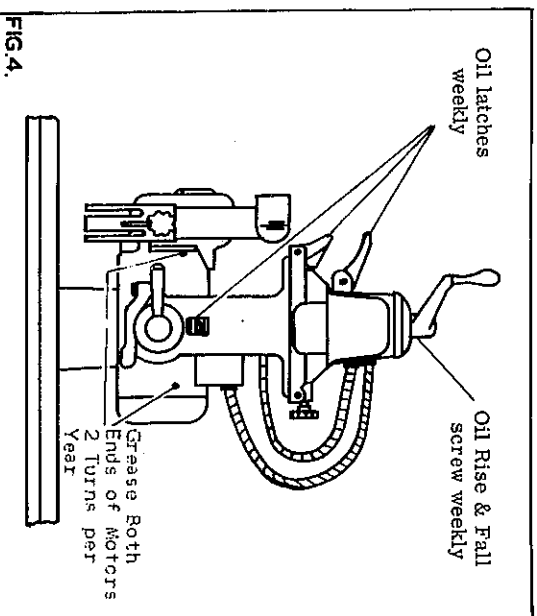

FIG. 4.

FOUNDATION

See Fig. 5 for bolt positions and clearance required.

When installing, the machine must be levelled up by means of packing pieces under the feet. The machine table should be slightly high at the front end. This will ensure that the saw unit remains in the back position when not in use.

This does not affect the accuracy of the machine. Foundation bolts are not supplied with the machine except by special order.

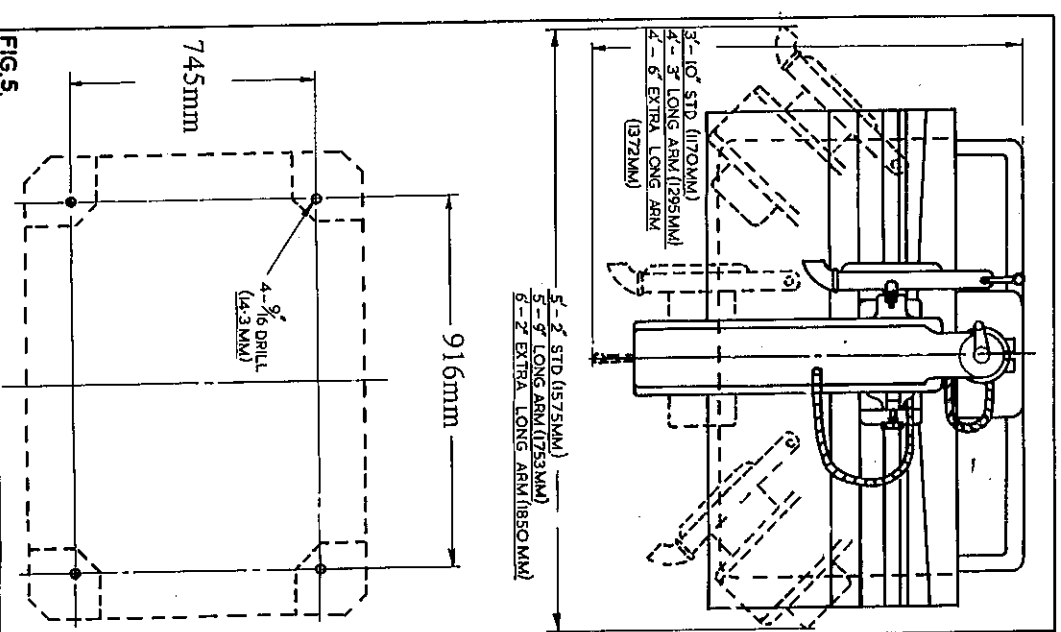

FIG. 5.

All adjustment and alignments listed below have been carefully set and checked and the whole machine thoroughly tested before despatch from the works.
Should any adjustment be necessary proceed in accordance with the relative instructions given.

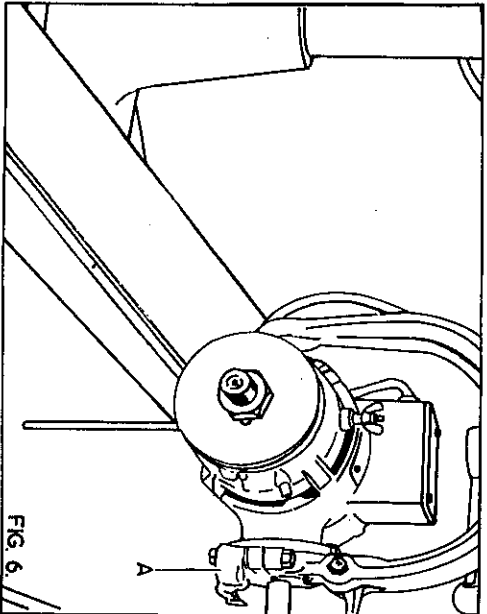

FIG. 6.

LEVELLING TABLE

To check the table for alignment to the arm the undermentioned procedure should be followed :-

1. Remove the sawguard and blade from the motor.
2. Ensure the motor locating latch "A" in Fig. 9, the stirrup locating latch "B" and the carriage locking screw "C" in Fig. 16 is securely locked.
3. Secure a small dia. rod between saw flanges as shown in Fig. 6 then raise or lower arm until end of the rod almost touches table.
4. Lift arm locating latch "C" in Fig. 9 and swing arm to extreme ends of the table checking that clearance between rod and table remains constant.
5. Should the table need adjustment remove table packing pieces and fence, adjust table supports by loosening hexagon head bolts and moving up or down whichever is required. When set tighten all bolts.
6. Replace fence in position required and replace packing pieces and wedges.

SAW ALIGNMENTS

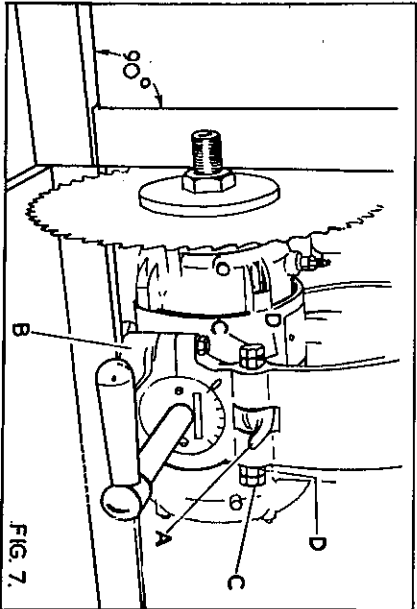

FIG. 7.

1. **Saw square to table**
To check this alignment, place a steel square against the saw as shown in Fig. 7. If adjustment is necessary, disengage the motor locating latch "A", loosen motor pivot locking handle "B" and adjust sawblade until square. Lock in this position with lever "B", then adjust airtight hexagon nuts "C" and hexagon locknuts "D" until latch "A" locates accurately in the motor locating ring.
2. **Line of travel to fence**

To check this alignment place a pencil between the saw flanges, as shown in Fig. 8 and scribe a line on the table. Check this is at 90° to the fence by means of a steel square. If adjustment is necessary, loosen arm locking lever "A" in Fig. 8, and disengage the pillar locating latch "B", adjust arm until square, lock in position; then adjust airtight hexagon nuts "C" and hexagon locknuts "D" until the latch "B" locates accurately in the pillar.

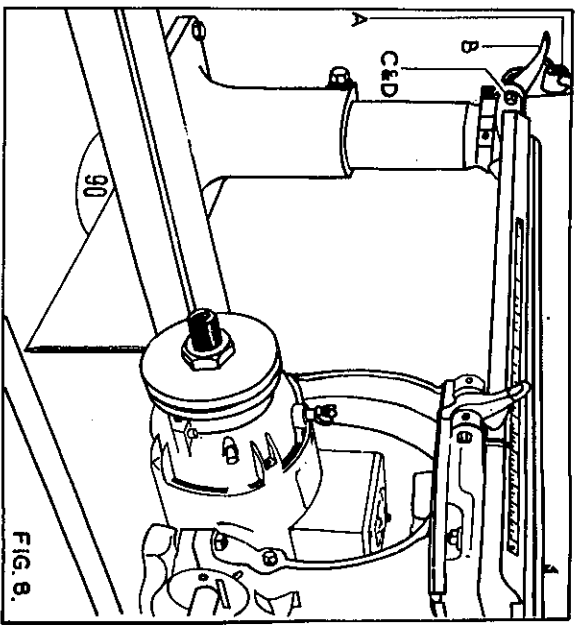

FIG. 8.

3. **Sawblade in relation to fence.**

To check this alignment place a steel rule or some other similar straight edge between the saw flanges as shown in Fig. 9 and a steel square against the fence. Rotate the steel rule from front to rear. If adjustment is necessary loosen stirrup locking handle "D", and disengage the stirrup locking latch "B", set correctly, then relock in position with lever "D". Adjust the airtight nuts "E" and hexagon locknuts "F" until the latch "B" locates accurately in the slot in the stirrup.

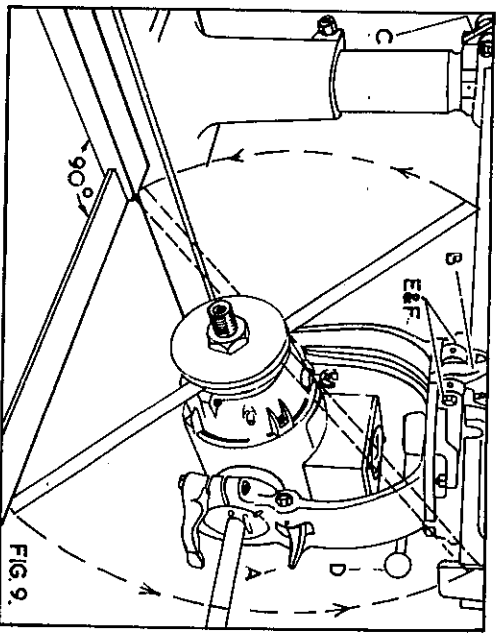

FIG. 9.

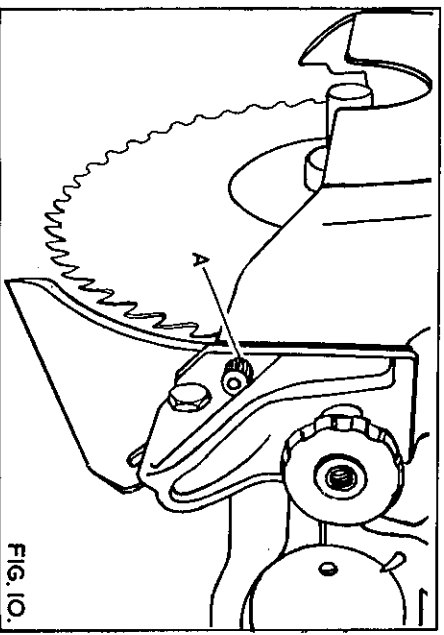

FIG. 10.

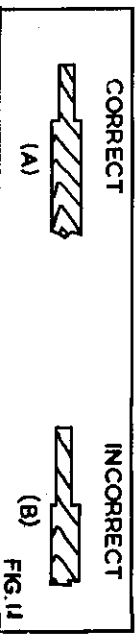

FIG. 11.

RIVING KNIFE ALIGNMENT

The riving knife should be central between the set of the saw. Should the riving knife be incorrectly positioned loosen the two socket head cap screws "A" in Fig. 10. Place a steel rule or some other straight edge along the riving knife and set central to saw. With the riving knife in this position re-tighten the two socket head cap screws "A".

To check this setting feed a short piece of timber from the rear, along both sides of the riving knife. If the riving knife is correctly set the blade should cut an equal shoulder as shown in Fig. 11 (a) not an unequal shoulder as shown in Fig. 11 (b)

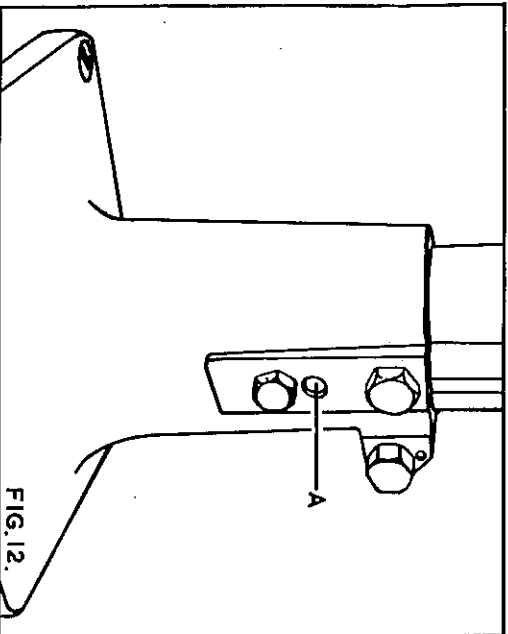

FIG. 12.

COLUMN ADJUSTMENTS

Movement in the arm may be traced to the pillar. To take up any play which may develop adjust the special socket head cap screw "A" in Fig. 12. After adjustment the pillar rise and fall should be checked to ensure the movement is not too tight.

SAW GUARD

The guard gives maximum protection for all operations. The guard is fitted with an anti-kick back device as shown in Fig. 13 and riving knife for ripping. The riving knife is easily detachable and can be replaced by a sheet steel visor when used for crosscutting. The visor is adjustable throughout the full depth of cut of the machine. An adjustable rubber dust exhaust is fitted to the guard to direct the sawdust away from the operator.

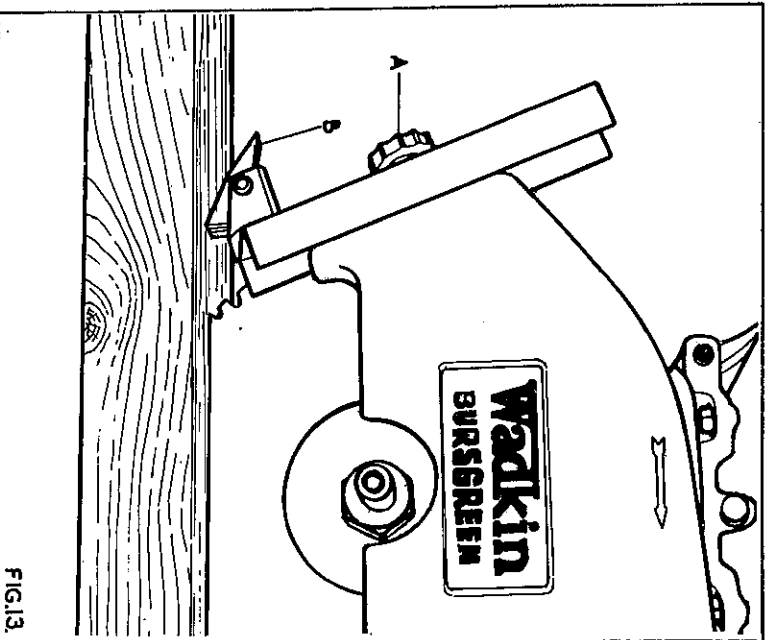

FIG. 13

HOW TO ADJUST KICK BACK FINGERS

The anti-kick back fingers are fitted to the saw guard and they are adjustable throughout the full depth of cut of the machine.

To set kick back fingers correctly:-

1. Place timber to be ripped in kick back fingers as shown in Fig. 13.
2. Loosen handwheel "A", then lower the fingers until they come in contact with the timber. Press bracket a further $\frac{1}{8}$ " (3mm) hold in that position, re-lock handwheel "A".
3. To remove timber press the point of kick back fingers at "B" towards the table and withdraw the timber.

The timber can now be ripped without any danger of it being kicked back at the operator.

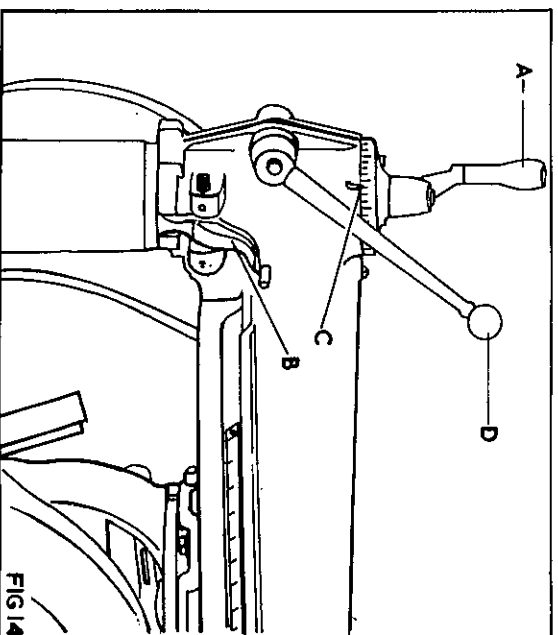

FIG. 14

RISE AND FALL OF THE ARM

The arm rise and fall is by means of the handle "A" in Fig. 14. The handle turns a screw in a brass nut which is anchored to the foot. The total travel of the arm is 14" (356mm)

SWIVEL OF THE ARM

The arm swings 45° each way to the fence with the principle angles located by a tapered latch "B" in Fig. 14. The angles to the fence line are indicated by a pointer on the arm bearing cap at "C".

A powerful lock is provided and can be applied by lever "D".

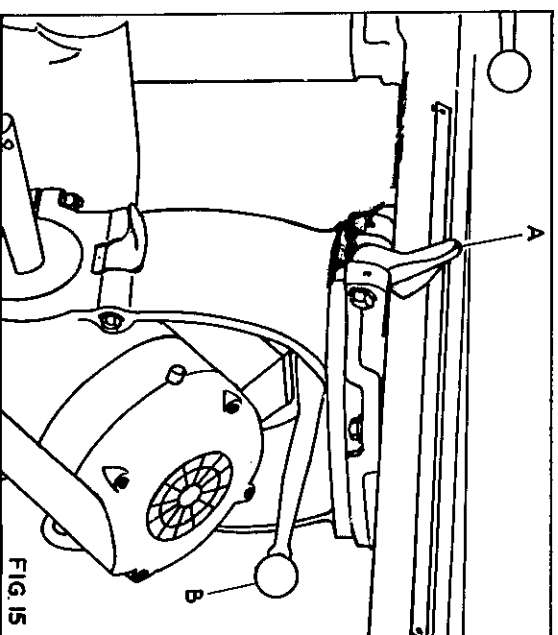

FIG. 15

CARRIAGE AND MOTOR UNIT

The carriage is mounted on four sealed for life ball bearing rollers grooved to coincide with the circular slideways on the arm. The carriage can be locked in any position along the arm by means of the handwheel on the right of the carriage.

The stirrup is fastened to the carriage by a central pin which enables the motor to swivel through 360°. The principle angles are located by a tapered latch "A" in Fig. 15.

The stirrup can be locked at any angle by the lever "B".

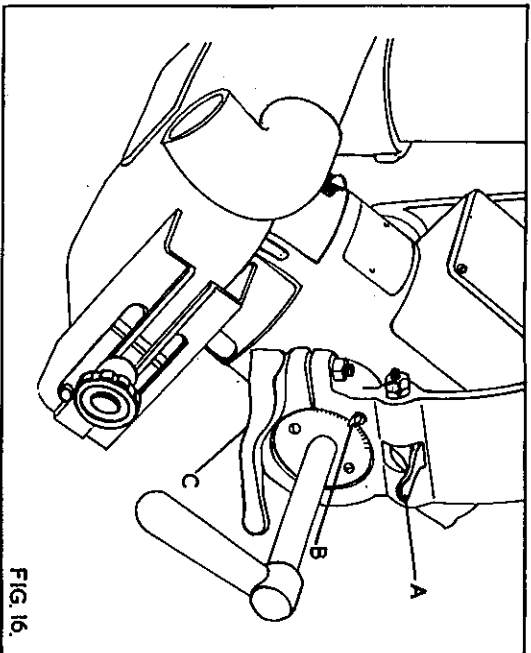

FIG. 16.

The motor swivels within the stirrup through 90°. The principle angles are located by a tapered latch "A" in Fig. 16. The angle of cant is clearly shown on a graduated scale by the pointer "B".

The motor can be locked at any angle by the locking lever

"C".

CAUTION
SUPPORT MOTOR BEFORE RELEASING LOCKING LEVER 'C' & PLUNGER 'A'.

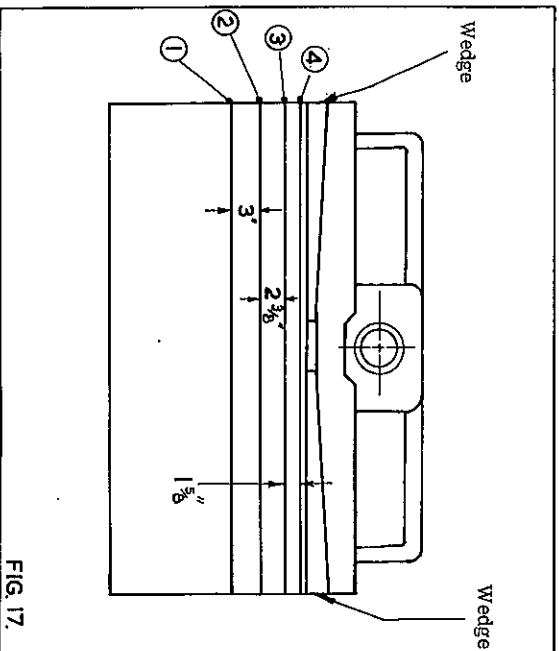

FIG. 17.

WOOD TABLE

The wood table is made in such a way to give four fence positions. The fence can easily be moved from one position to another by knocking out the wedges and placing the table strips to suit whichever fence position is required.

POSITION 1.

This enables a maximum timber size of 14" wide x 4 1/2" deep (356mm x 114mm) to be crosscut with the arm at 90°.

POSITION 2.

This enables a maximum timber size of 17" wide x 1" deep (432mm x 25mm) to be crosscut with the arm at 90°.

POSITION 3.

This is the most convenient fence position when cutting compound angles with the arm swung to the left of the operator.

There is a rule fitted to each side of the arm for use when ripping. The fence positions, so that these rules show the correct sizes, are as follows :-

1. When ripping from the right hand side of the machine the rule nearest the operator will read correctly with the fence in position 4.
2. When ripping from the left hand side of the machine the rules nearest the operator will read correctly with the fence in position 1.

FITTING SAWBLADES

To fit sawblades the undermentioned procedure should be followed :-

1. Remove the sawguard complete from the motor.
2. Fit long arm hexagon wrench into spindle end and remove the spindle locknut, left hand thread, and remove front saw flange.
3. Fit saw to spindle taking care to ensure the teeth are pointing in the correct direction, also the saw flanges and saw are clean and free from any dirt or sawdust.
4. Replace saw spindle nut and sawguard.

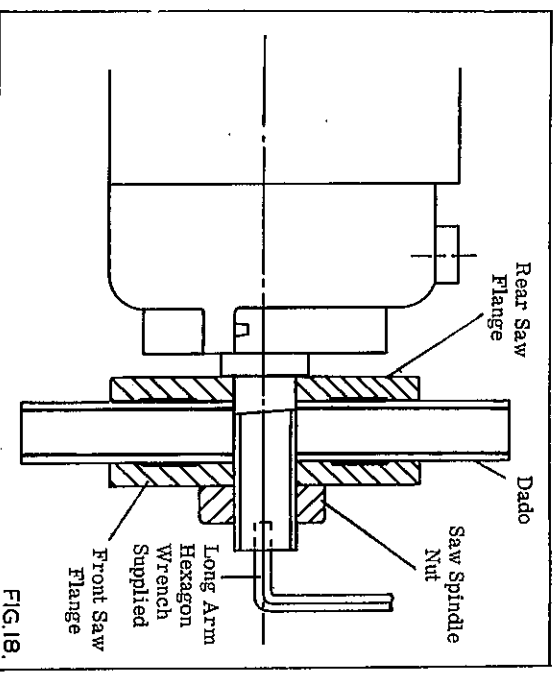

FIG. 18.

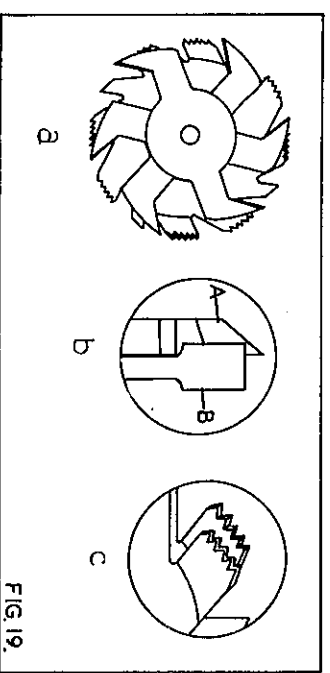

FIG. 19.

HOW TO FIT DADO

A dado head is made up of two outside saws and 5 inner cutters. Various combinations of saw and cutters are used to cut grooves from 1/8" to 1" wide (3mm to 25mm). Inner cutters are heavily swaged and must be arranged so that the heavy portion falls in the gullets of the outside saw as shown on Fig. 19 (1), Fig. 19 (b) shows how the saws and cutters overlap "A" being the saw and "B" being the inside cutter. A 1/4" (6mm) groove is cut by using the two outside saws fitting the ground teeth directly opposite as shown in Fig. 19 (c) in order to allow clearance for the slight set of the saw teeth.

The dado is secured on the spindle between the standard saw flanges as shown in Fig. 18. To fit dado head remove the sawguard and front saw flange, also remove the driving peg from the rear saw flange. Fit the outer saws and required inner cutters onto the spindle and lock in position, then replace sawguard.

HOW TO FIT MOUNTING CUTTERBLOCKS

The cutterblocks are mounted on the end of the spindle as shown in Fig. 21.

To mount cutterblocks remove the sawguard and saw flanges fit the 1.1/8" (28.5 mm) long distance piece supplied onto the spindle then the cutterblock. The special locknut and spanner, type QT. 37, should be used to lock the block in position.

The special guard can be supplied for use with these blocks.

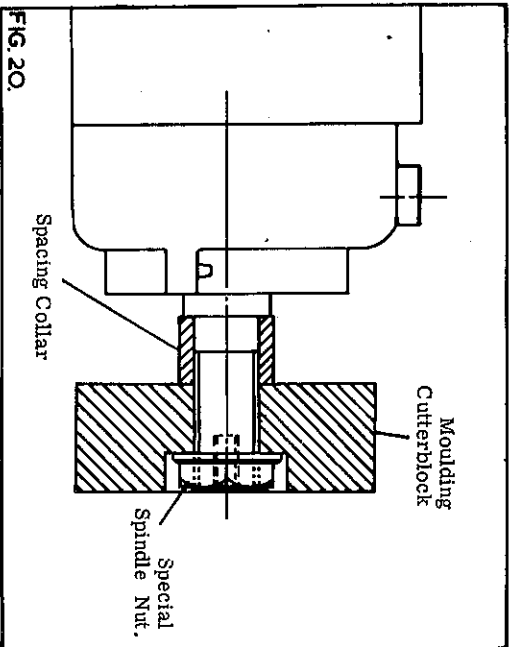

FIG. 20.

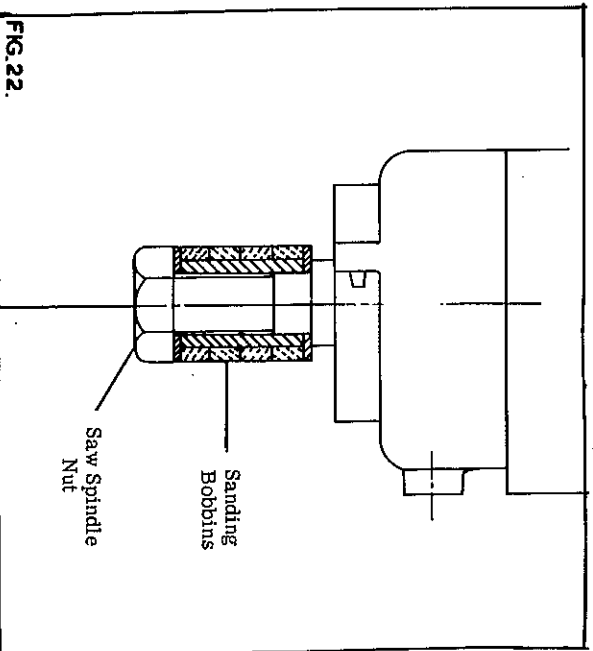

FIG. 22.

HOW TO FIT SANDING BOBBINS

The sanding bobbins consist of four rubber sections each $\frac{1}{2}$ " (12.5mm) thick mounted on a sleeve flange at each end.

Before mounting the bobbins onto the spindle, the sawguard and saw flanges should be removed and the bobbins fit onto spindle as shown in Fig. 22 and locked onto the spindle with the standard arbor nut, left hand thread.

SAW MAINTENANCE

Efficient operation of a circular saw depends on true running of the saw spindle and the collars being perfectly square on the faces with the axis of the spindle, it must run at the correct peripheral speed to ensure straight cutting. The Bursgreen radial arm saw embodies all these requirements and provided the saw is maintained in a sharp condition with the teeth correctly sharpened and set, efficient service will be given.

Before putting a new saw to use, it is essential that it is "ranged down" on the teeth to ensure each tooth is cutting and to maintain true running.

RANGING

Ranging down should be done on a new saw or any saw after the 4th or 5th re-sharpening.

Feed a square edged abrasive block, in wooden holder, lightly against the saw teeth whilst running. The saw should then be removed and the tops of the teeth filed to remove the ranging marks on the points.

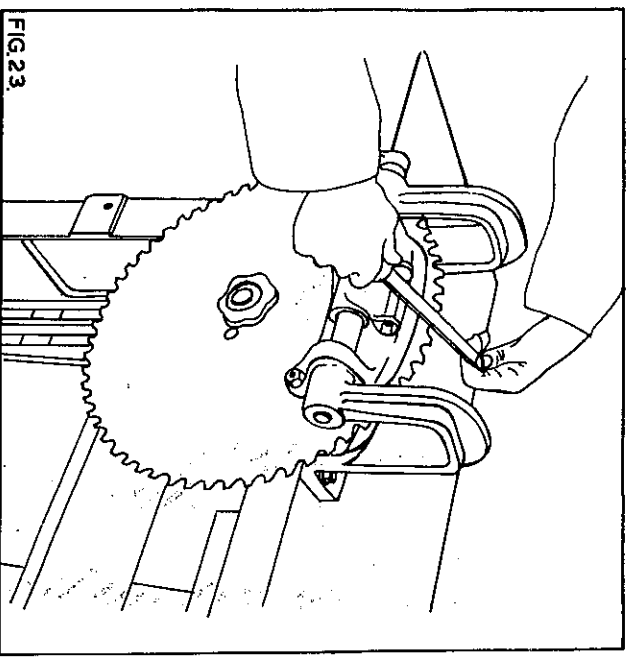

FIG. 23

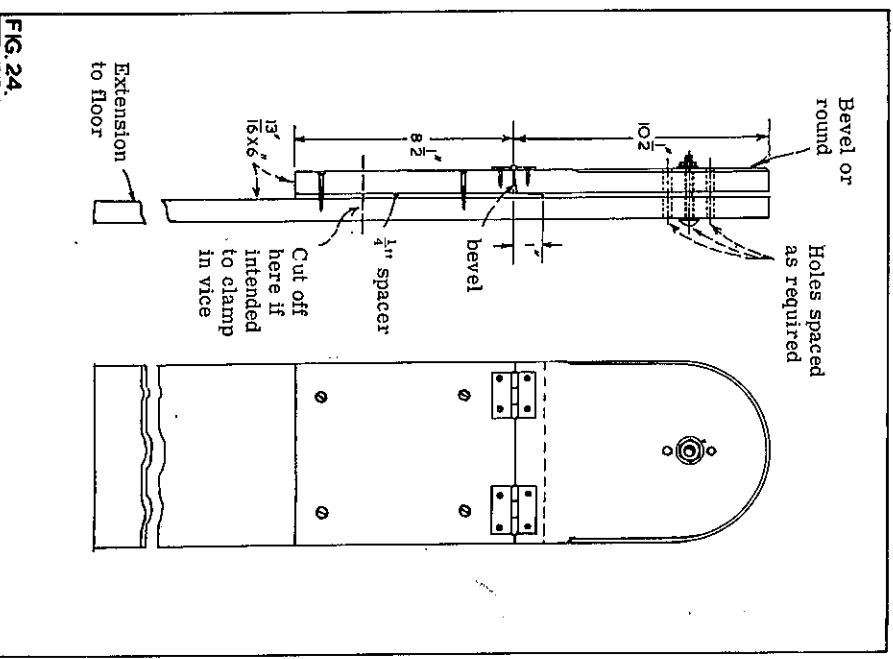
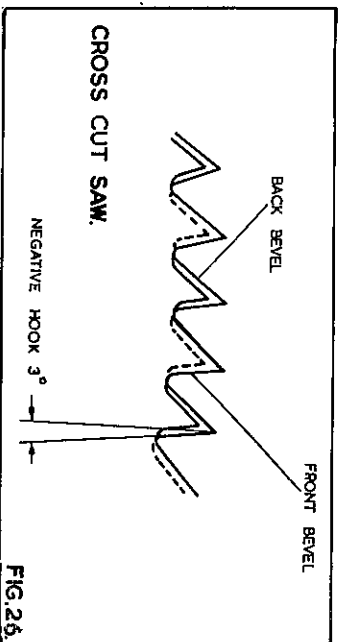
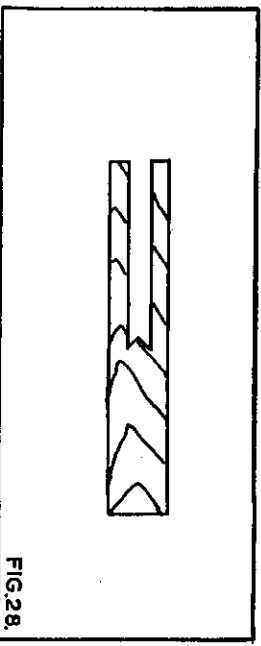
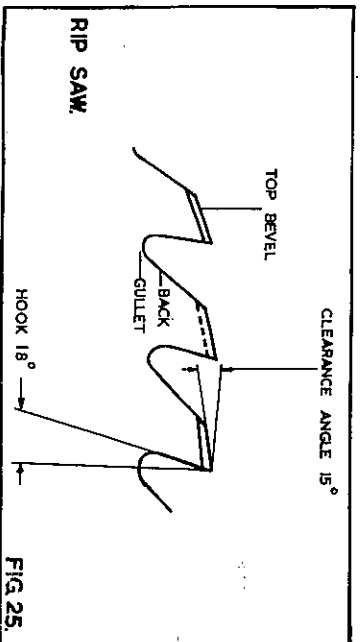

FIG. 24.



SAW SHARPENING

Do not run a saw when blunt, remove and re-sharpen. Hold a saw rigid in a vice as shown in Fig. 23 or a simple saw vice as shown in Fig. 24 which can be readily made and proceed to sharpen saw.

With rip saw teeth, chisel edges and square faces are needed see Fig. 25. Sharpen by giving each tooth an equal number of strokes with a flat faced saw file with rounded edges. At the same time file the gullet, taking care to keep the gullet well rounded.

With a crosscut saw, saw points are needed with back and front bevels, as shown in Fig. 26.

In the course of repeated filing the teeth loose the original shape and the gullets shallow. To restore the shape of each tooth, essential for satisfactory performance, it is necessary to grind the saw on a saw sharpening machine. These machines are usually of the automatic type and feeds each tooth, giving equal spacing or pitch.

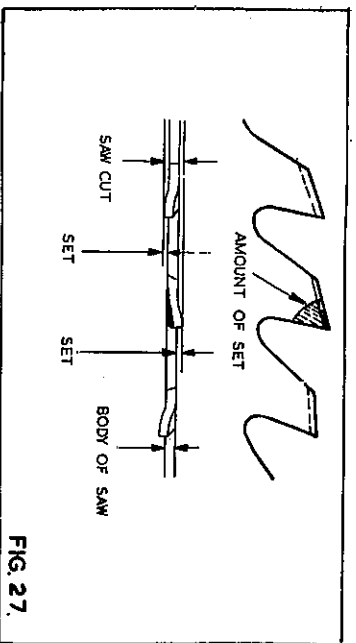
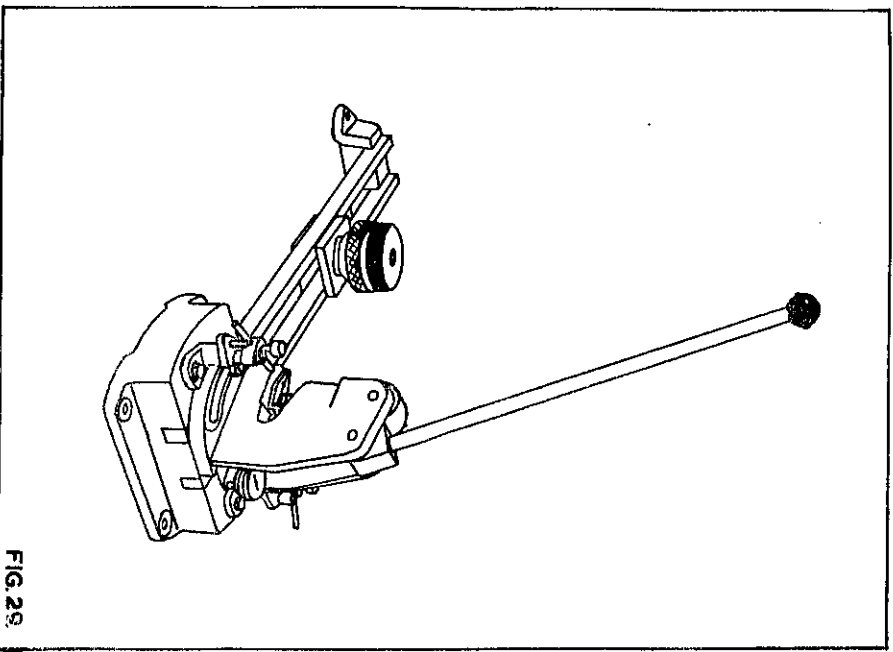

SETTING

The amount of set to the teeth should be sufficient to give clearance to the body of the saw so that there is freedom from friction between saw and timber. It is generally accepted that the teeth are "spring set" i. e. the tips of alternative teeth are bent to the right and left as shown in Fig. 27. For good sawing the amount of set on each side of the saw must be identical otherwise the saw will run to one side. To check the set, cut into a piece of wood of few inches when a small even triangle should be seen, Fig. 28.

The exact amount of set each side varies with the timber being cut, usually .010" to .015" (.03mm to .04mm)

For clean cutting, just sufficient set should be allowed to prevent bending and heating. More set is required for wet, woolly timber than for dry, close grained timber and the amount of set is greater for corsscutting saws than those for ripping.

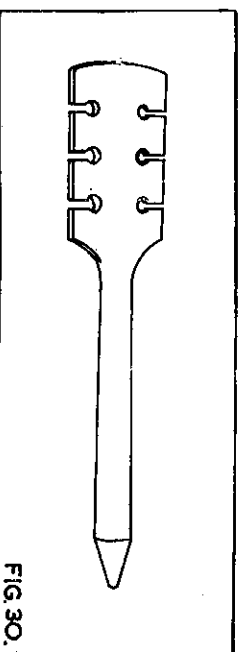

MACHINE SETTING

We can supply a small machine for efficiently setting the teeth as illustrated in Fig. 29 and will deal with saws 8" to 36" (202mm to 910 mm) diameter. The micrometer that indicates accurate reading of the amount of set in thousandths of an inch.

HAND SETTING

Where the number of saws does not warrant a machine being installed the saws are set by hand using a tool shown in Fig. 30. This tool is provided with six notches to take saws 8 to 14 gauge thick.

For this process of setting, the saw is securely clamped in a vice,

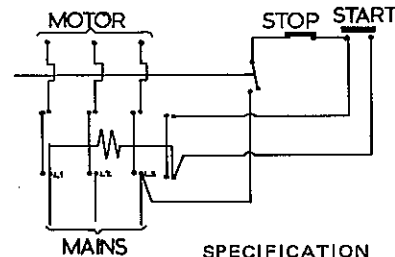
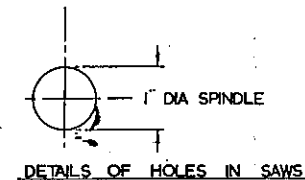
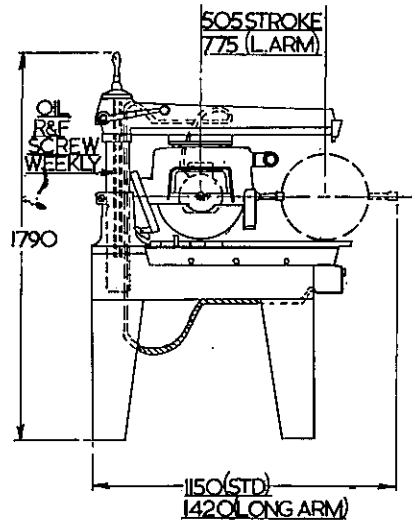
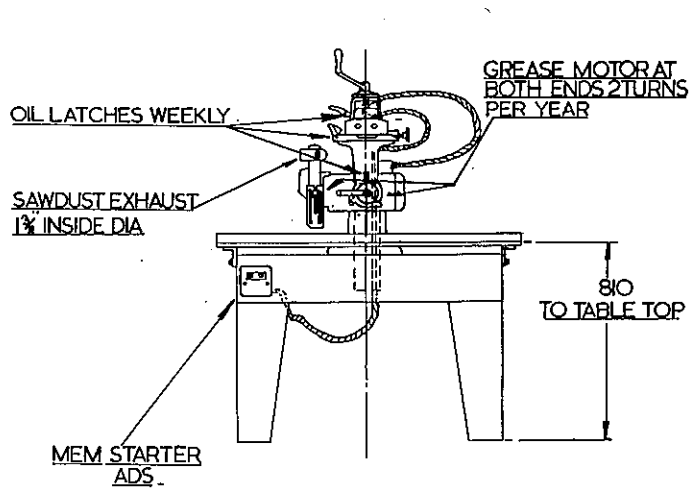

WIRING DIAGRAM

MEM STARTER ADS

LENGTH OF CABLE LOOP 850 (STD)

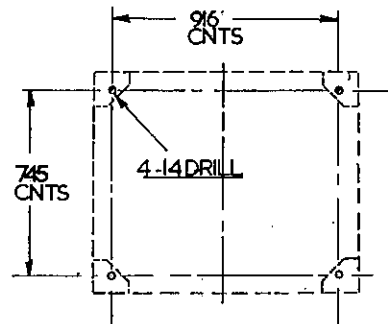
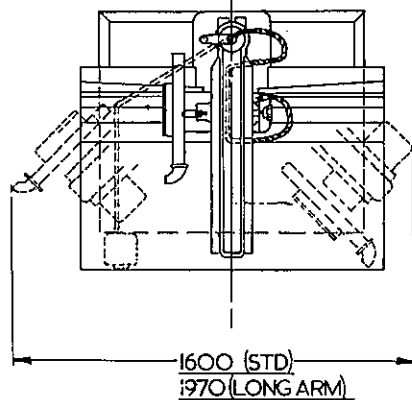

BASE OUTLINE

SPECIFICATION

Maximum diameter of saw	.350mm
Maximum saw projection	.108mm
Width will cross cut with standard arm at 90 deg.	.415 x 108mm 480 x 25mm
Width will cross cut with standard arm at 45 deg.	.227 x 108mm 288 x 25mm
Maximum width grooving head	.50mm wide
Maximum ripping capacity	.680mm
Height of work table	.805mm
Diameter of saw spindle	.30mm
Power of motor	.3kw
	4.5kw (Optional)
Speed of motor 50 Hertz	.3000 rev/min
Speed of motor 60 Hertz	.3600 rev/min
Maximum overall height	.1790mm
Floor space	.1600 x 1070mm
Net Weight (approx)	.210kg
Gross Weight (approx)	.316kg
Shipping Dimension (approx)	.099 cu.m.

Type of Grease recommended Shell Alvania 3
 Type of Oil recommended Power EM 125

NOTE:- BEFORE USING M/C MUST BE LEVELLED BY PACKING PIECES UNDER THE BASE FEET. A SPIRIT LEVEL SHOULD BE PLACED ON THE TABLE MOUNTING STRIPS. MACHINE PACKED UNTIL THE STRIPS ARE SLIGHTLY HIGH AT THE FRONT END. THIS WILL ENSURE THAT THE SAW UNIT REMAINS IN ITS BACK POSITION WHEN NOT IN USE. THIS DOES NOT EFFECT THE ACCURACY OF THE MACHINE

BEARINGS USED
 4-FG 3400 ROLLER BEARINGS (FBC)
 1-51202 THRUST RACE (SKF)

UNIVERSAL CROSS CUT SAW		BURSGREEN DURHAM FENCE HOUSES TYNE & WEAR	
FOUNDATION DRAWING	SCALE 1:10	DRAWN BY CC DATE 14-4-78	TRACED BY CC
		DRAWING NUMBER D 350 BRA/FD	

PILLAR ASSEMBLY

Ref. No.	Part No.	No. Off	Description
1	BRA 135	1	Pillar
2	BRA 14	1	Rise & Fall screw
3	BRA 134	1	Foot
4	BRA 46	1	Rise & Fall nut locking screw
5	BRA 13	1	Rise & Fall nut
6		1	M16 Aerotight nut
7		1	M6 Dia x 25 Long socket head grubscrew
8		1	M16 x 125 Long hexagon head bolt
9	BRA 47	1	Rise & Fall nut adjusting screw
10		1	M12 x 50 Long hexagon head bolt
11		4	M12 x 60 Long hexagon head bolt
12	1026/22	4	Washer for foot
13		1	10mm External circlip
14		1	No. 4 Black plastic handle
15	BRA 33	1	Rise & Fall handle
16	A-S-245	1	Spindle for rise & fall handle
17		1	5mm Dia x 40 Long groverlock spring
18			dowel
19	BRA 51	3	M8 x 35 Long socket head capscrew
20	SKF51202	1	Rise & Fall handwheel bearing
21	BRA 70	1	Thrust race
22		1	Rise & Fall screw collar
23	BRA 94	2	6mm Dia x 44 Long fluted dowel
24	No. 2	1	Pointer
25	MS 127152	1	1/4 Long hammer drive rivot
26	BRA 236	1	M10 Tap x 1 1/4" Dia black plastic ball
27			Arm locking handle c/w M10 x .25 long socket head grubscrew
28	BRA 234	1	Arm locking bolt
29	BRA 20	1	Arm locating latch
30		2	M12 Locknut
31	BRA 235	2	M12 Aerotight nut
32		1	Arm locking handle nut
33	BRA 41	1	M8 x 20 Long socket head grubscrew
34		1	Pivot pin for locating latch
35	BRA 48	3	M10 x 10 Long socket head grubscrew Locating bolt

Machine Parts List

IMPORTANT.

WHEN ORDERING REPLACEMENT PARTS, PLEASE QUOTE PART NUMBER AND SERIAL NUMBER OF MACHINE.

**For Replacement Parts, Tools & Accessories,
Contact Spares Dept., Ext. 45,
Bursgreen (Durham),
Fence Houses, Houghton ~le ~ Spring,
Tyne ~ Wear DH4 5RQ, England.**

Telephone: Fence Houses 852385 (5 lines)

Telex : 53441 (Bursgreen Duram)

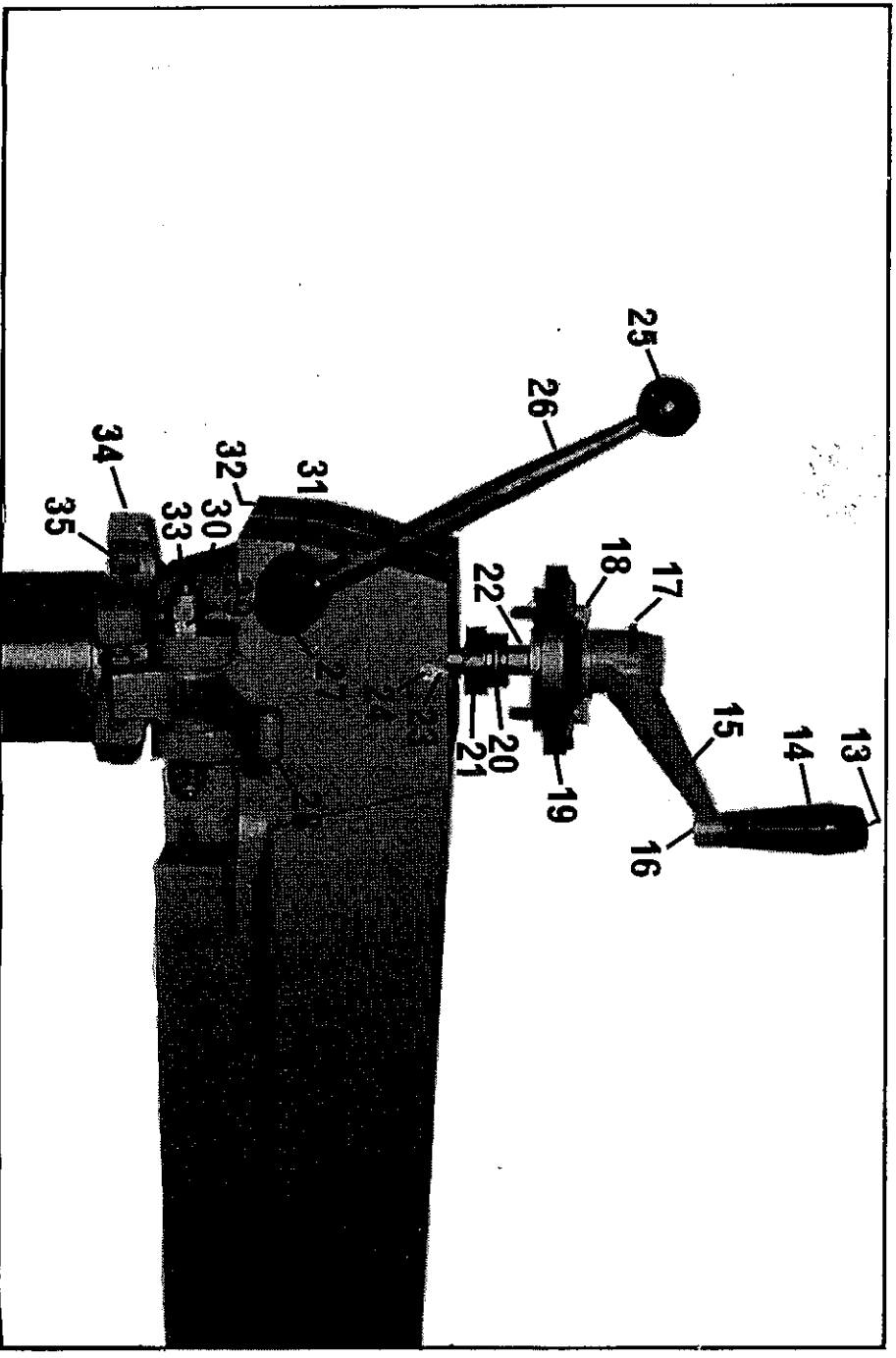
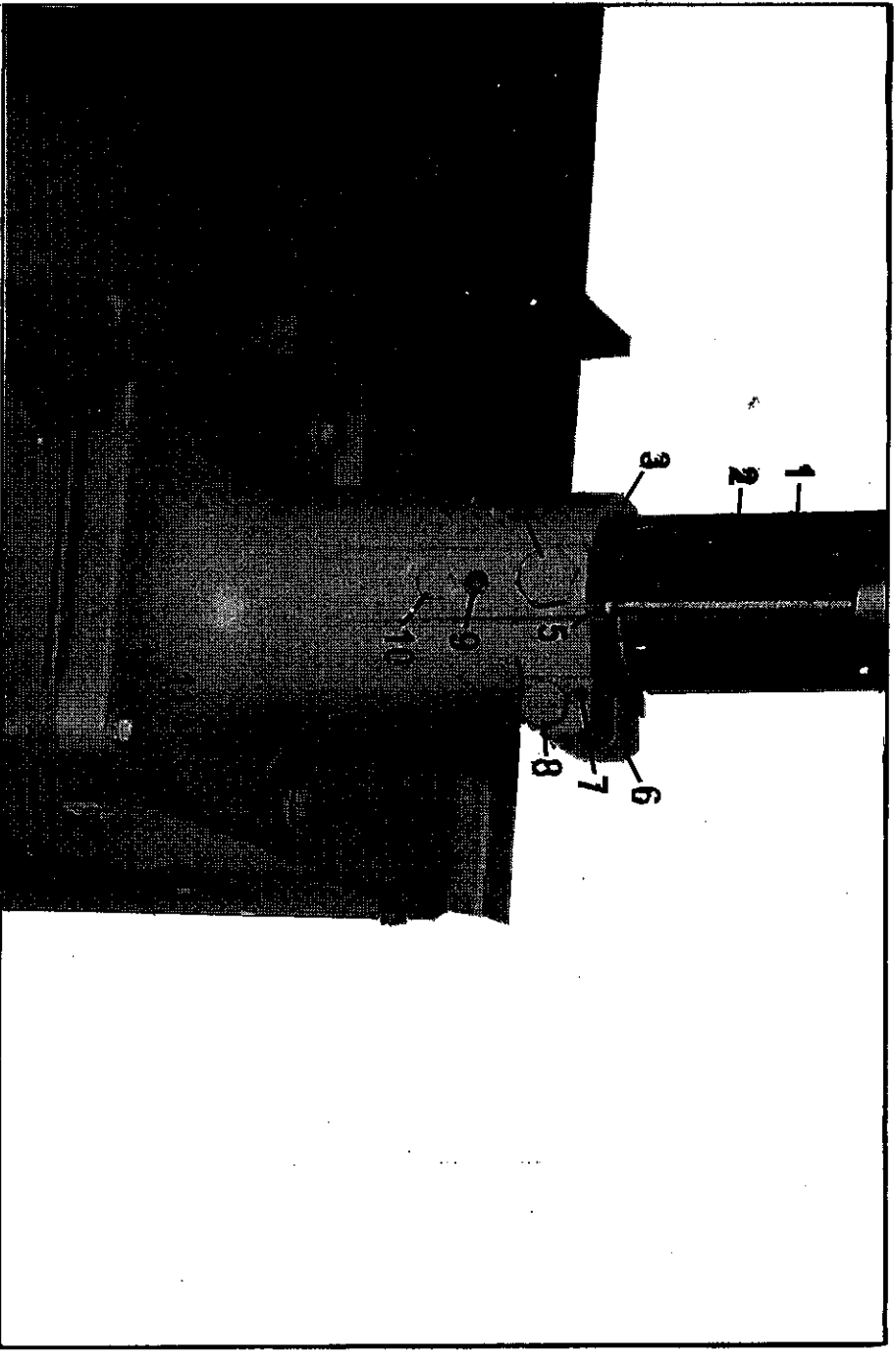

ARM ASSEMBLY

Ref. No.	Part No.	No.		Description
		Off	Off	
45	BRA 23	1		Arm end cap
46		2		M10 x 30 long socket head capscrew
47		8		M5 x 10 long button head socket screw
48	BRA 28	1		Left hand arm plate - 430 arm
	BRA 29	1		Right hand arm plate - 430 arm
	BRA 30	1		Left hand arm plate - 700 arm
	BRA 31	1		Right hand arm plate - 700 arm
49		1		Rubber stop for end cap
50		8		M4 hexagon head nut - 430 arm
		10		M4 hexagon head nut - 700 arm
51		8		M4 x 25 long socket head capscrew-430arm
		10		M4 x 25 long socket head capscrew-700arm
52	BRA 49	2		Slide rod - 430 arm
	BRA 50	2		Slide rod - 700 arm
53		2		1/8" dia x 6mm long pop rivot
54	BRA 116	1		Metric rule for 430 arm
	BRA 117	1		Metric rule for 700 arm
	BRA 118	1		Imperial rule for 430 arm
	BRA 119	1		Imperial rule for 700 arm
55	BRA 15	1		430 Capacity arm
	BRA 16	1		700 Capacity arm

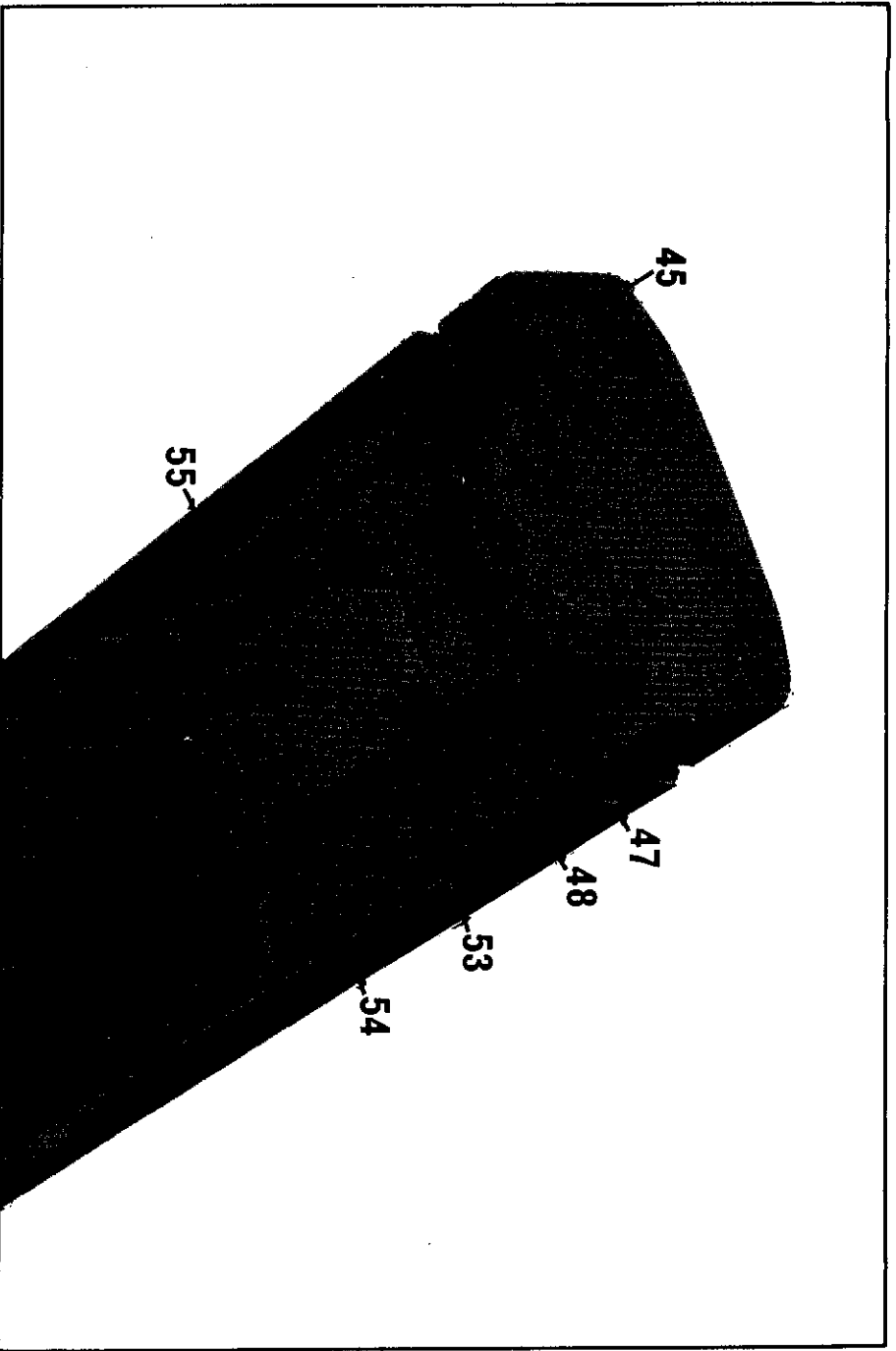

BASE AND TABLE ASS'Y

Ref. No.	Part No.	No. Off	Description
60	BRA 71 BRA 72	1 1	Outer support bracket - Left hand Outer support bracket - Right hand
61		18	M10 x 25 Long hexagon head bolt
62		12	M10 Hexagon head nut
		6	M10 Hank bush
63	BRA 53	1 1	Base
64	BRA 64	1 1	Central support bracket - 430 arm
	BRA 73	1 1	Central support bracket - 700 arm
65	BRA 3	4 4	Leg for base
66	BRA 108 BRA 92	1 1	Table - 430 arm Table - 700 arm
67		1 1	52mm Wide fence
68		1 1	63mm Wide table fence 63mm Wide table head
		1 1	80mm Wide table strip - 350 & 400
		1 1	crosscut head
69		1 1	37mm Wide table strip - 350 & 400 universal head
		1 1	63mm Wide table strip - 350 & 400 crosscut head
		1 1	58mm Wide table strip - 350 universal head
70		1 1	25mm Wide table strip - 350 & 400 universal head
		1 1	37mm Wide table strip - 350 & 400 crosscut head
71	BRA 96	1 1	Right hand back support
72	BRA 97	2 2	Table wedge
73	BRA 104	2 2	Back support packing piece
74	BRA 95	1 1	Left hand back support

SEMI-UNIVERSAL HEAD ASSEMBLY

Ref. No.	Part No.	No.		Description
		Off		
80	BRA 89	3		Eccentric roller pin
81	FAFNIR SD 5649	4		Convex roller bearing
82	BRA 79	4		Washer for bearing
83	BRA 69	1		Rubber stop
84	BRA 67	1		Back stop
85		2		M8 Wingnut
86		2		M8 x 30 Long stud
87	BRA 57	2		Sawguard locking shoe
88		2		M8 x 10 Long button head socket screw
89	BRA 24	2		Saw flanges (30mm Bore.)
90	BRA 44	1		Saw spindle nut (30mm Fine thread.)
91	BRA 91	1		Plain roller pin
92		4		10mm Washer
93		4		10mm Nut
94	BRA 10	1		Motor packing and roller bracket
95		1		Motor (Refer to motor plate for required motor.)
96		2		M8 x 25 Long socket head capscrew
97		2		M5 x 20 Long button head socket screw
98	BRA 56	8		Motor plate locking shoe
99		2		M8 x 25 Long button head socket screw
100	BRA 220	1		Pull handle bracket
101	BRA 221	1		Pull handle shaft
102	PATF.NO.952	1		Black plastic handle
103	BRA 89	3		Eccentric roller pin
	BRA 91	1		Plain roller pin
104	FAFNIR SD 5649	4		Convex roller bearing
105	BRA 79	4		Washer for bearing
106		4		10mm Washer
107		4		M10 Nut

UNIVERSAL HEAD ASSEMBLY

Ref. No.	Part No.	No. Off	Description
115	BRA 65	2	Plunger Handle
116		2	M8 x 25 Long hexagon head bolt
117		2	8mm Washer
118	BRA 19	1	Stirrup location plunger bracket
119	ETS 90	1	Spring
120	BRA 68	1	Location plunger
121	VOS-27-203	2	M8 Wingnut
122	VOS-26-234	2	M8 x 30 Long stud
123	BRA 57	2	Sawguard locking shoe
124		2	M8 x 10 Long button head socket screw
125		2	M6 x 12 Long socket head grubscrew
126		1	Front mounting plate
127		4	M8 x 25 Long socket head capscrew
128	BRA 56	6	Motor plate locking shoe
129	BRA 22	1	Front stirrup location pad
130	BRA 75	1	M8 x 20 Long hexagon head bolt
131	BRA 76	2	Locking bush for stirrup phasing washer
132	BRA 18	1	Stud for motor plunger bracket
133		2	Motor location plunger bracket
134		2	M6 x 12 Long socket head capscrew
135	BRA 68	1	M8 Aertight nut
136	ETS 90	1	Location plunger
137	BRA 94	1	Spring
138	No. 2	1	Pointer for motor pivot
139	KS127175	1	1/4 Long hammer drive rivot
140	BRA 54	1	Black 4" pull handle, M10 tap + screws
141	BRA 93	2	Pull handle
142	Z 6	3	Angle indicator scale
143	BRA 55	1	1/4 Long self tapping screw
144		1	M8 x 30 Long socket head capscrew
145	BRA 77	1	Front stirrup location piece
146	BRA 111	1	M10 x 110 Long hexagon head bolt
147	BRA 107	1	Stirrup locking washer
148		1	Motor pivot locking handle
149	1072-137	1	Stirrup locking handle
150		1	Plastic handle for stirrup locking lever
151	BRA 74	1	Washer for stirrup locking lever
152		1	M5 x 12 Long socket head grubscrew
153	BRA 61	1	Stirrup phasing washer
154	BRA 109	1	M6 x 6 Long socket head grubscrew
155		1	Rear stirrup location piece
156		1	Motor pivot locknut
157	BRA 115	1	1 3/4" Black plastic handwheel M10 tap
158	BRA 110	1	M10 x 60 Long stud
159	BRA 66	1	Travel lock end piece
160	BRA 67	1	Travel lock
161	BRA 69	1	Stirrup pivot pin
162	BRA 1	1	Back stop
163	BRA 9	1	Back stop
164	BRA 60	1	Rubber back stop
165	BRA 58	1	Roller bracket
166	BRA 59	1	Stirrup
			Rear stirrup locking washer
			Motor pivot pin
			Rear mounting plate

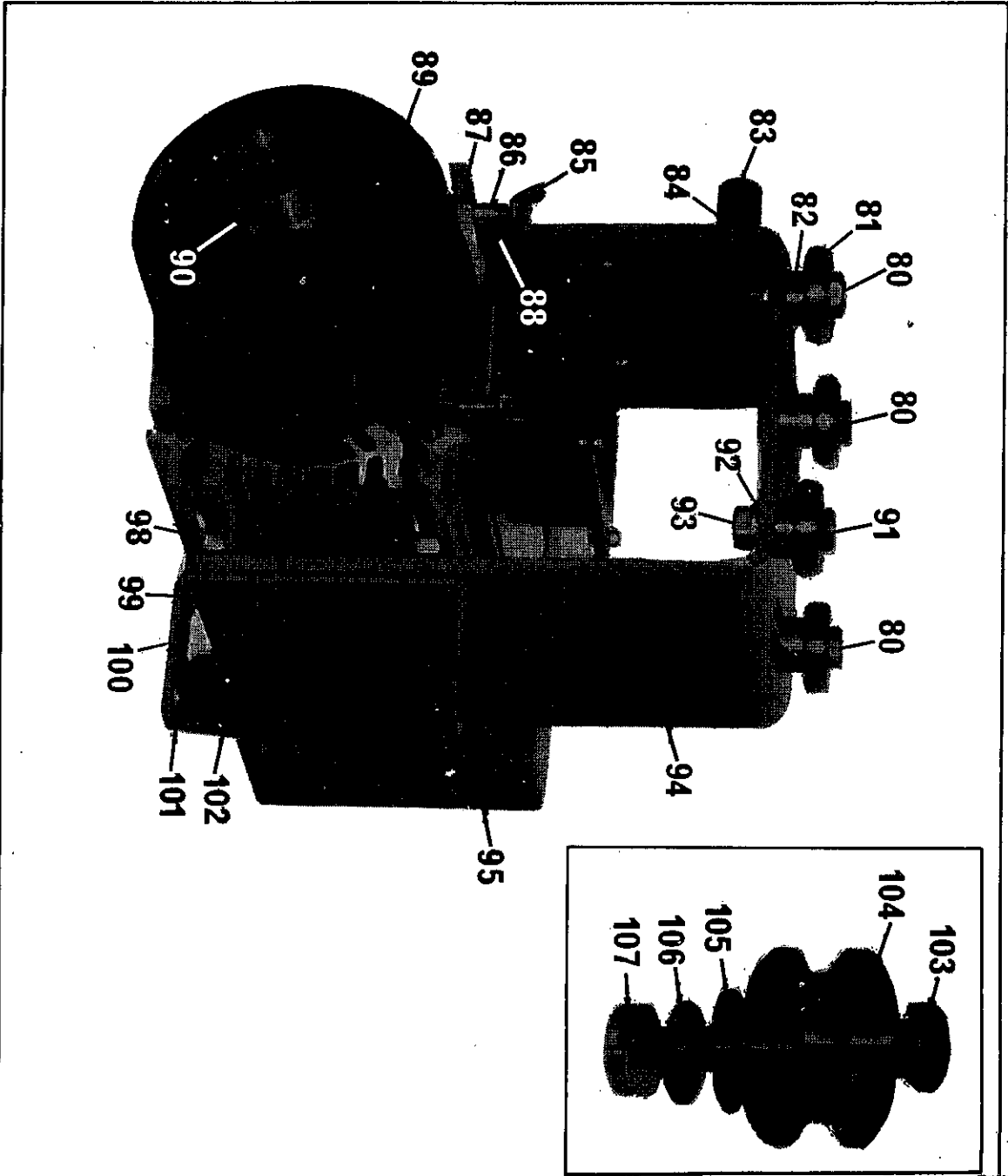

UNIVERSAL HEAD ASSEMBLY (Continued)

Ref. No.	Part No.	No.		Description
		Off	Off	
167		2		M8 x 35 Long socket head capscrew
168		1		Motor (Refer to motor plate for required motor.)
169	BRA 44	1		Saw spindle nut (30mm Fine thread.)
170	BRA 24	2		Saw flange (30mm Bore.)
171	BRA 85	2		Eccentric roller pin
172	FG 3400	4		Concave roller
	FAFNIR			
173	BRA 78	4		Washer for bearing
174	BRA 84	2		Plain roller pin
175	BRA 85	2		Eccentric roller pin
	BRA 84	2		Plain roller pin
176	SD 5649	4		Convex roller
	FAFNIR			
177	BRA 79	4		Washer for bearing
178		4		10mm Washer
179		4		M10 Nut

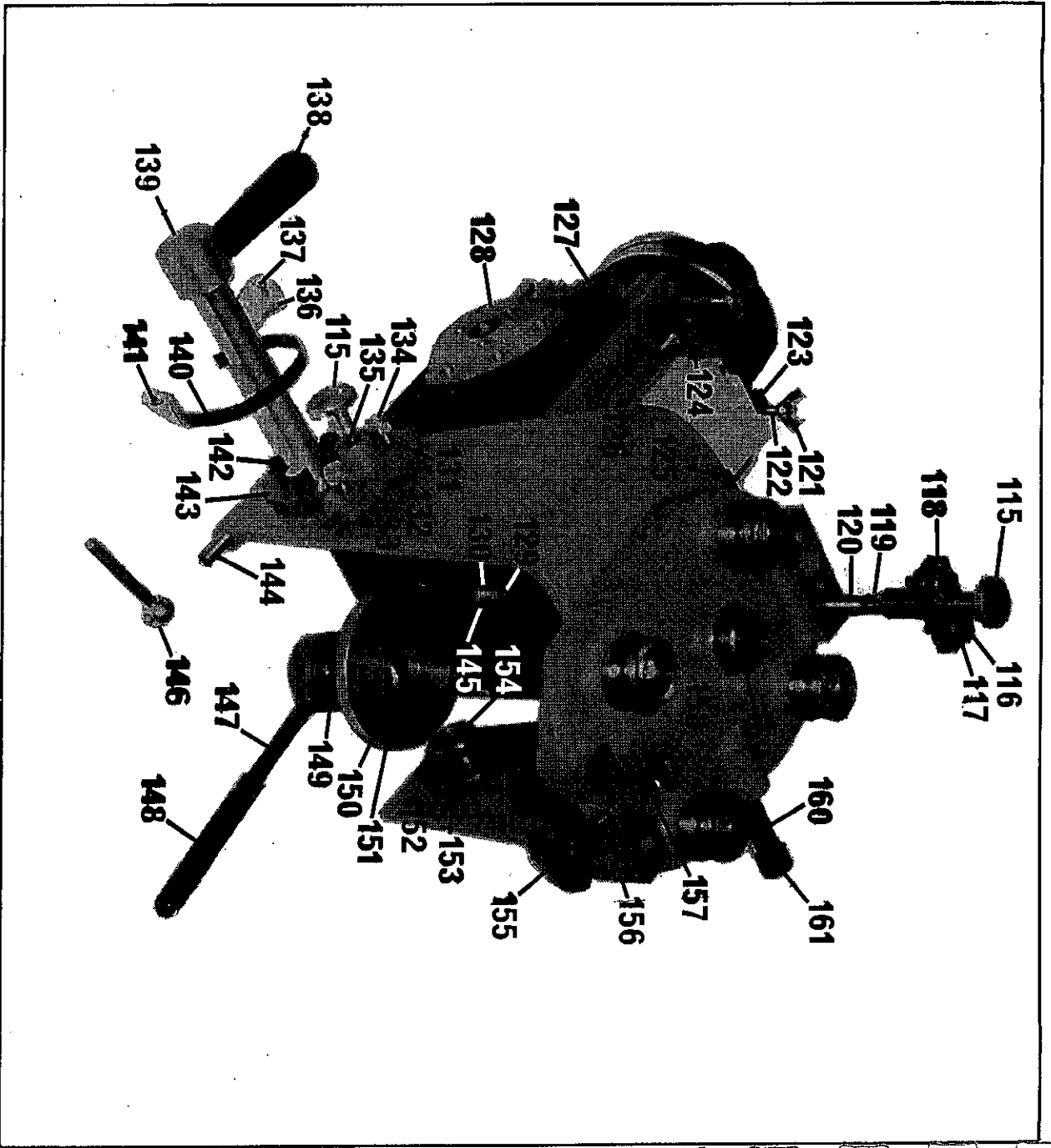

NOTE: WHEN RE-ORDERING, SPECIFY BORE OF SAWBLADE REQUIRED.

CIRCULAR SAWS

EXTRAS

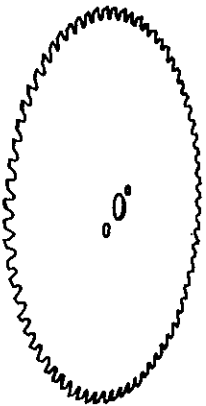

This is our standard range of saws, normally available from stock. Hollow ground saws require no setting, give minimum saw kerf or wastage and ensure exceptionally clean finish.

BS 102, 14" dia, BS 191, 16" dia
Crosscut Sawblade
14 gauge

BS 85, 14" dia, BS 192, 16" dia
Rip Sawblade
15 gauge

BS 119, 14" dia, BS 194, 16" dia
Hollow Ground
Crosscut Blade 12 gauge at tooth

BS 67, 14" dia, BS 193, 16" dia
Crosscutting or Ripping
Sawblade for exceptionally
smooth finish 14 gauge.

BS 74, 14" dia, BS 195, 16" dia
Hollow Ground Plywood Saw
12 gauge at tooth.

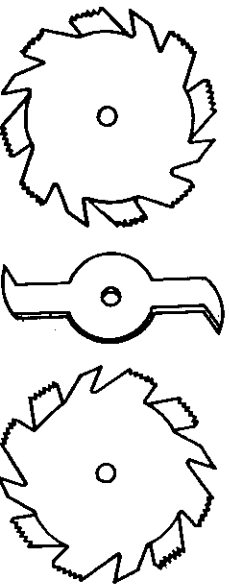

EXPANDING GROOVING SAW OR DADO HEAD

For smooth finish with or across the grain in hard or soft woods. The head consists of two outside saws $\frac{1}{8}$ " (3 mm) thick, 8" (202 mm) diameter and 5 inner cutters of varying thicknesses for cutting grooves $\frac{1}{8}$ " (3 mm) to 1" (25 mm) rising by 1/16" (1.5 mm

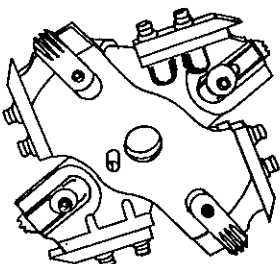

CUTTERBLOCKS

EXPANDING GROOVING HEADS

Each half of this head is made in gun metal giving exceptional strength.

J.P. 541

With 8 $\frac{1}{2}$ " (216mm) cutting circle, for grooves $\frac{3}{8}$ " (9.5mm) to 1 $\frac{1}{16}$ " (17.5mm) wide, 9/16" (14mm) deep.

J.P. 543

With 8 $\frac{1}{2}$ " (216mm) cutting circle, for grooves 1 $\frac{1}{16}$ " (17.5mm) to 1 $\frac{1}{4}$ " (32mm) wide, 1" (25mm) deep.

J.P. EXPANDING GROOVING HEADS CUT LIMITER

Set knives on J.P. heads to 8.5" \pm .005" dia. to ensure .020" max. knife projection above cut limiter.

QR.100

4 knife wedge type, flush mounted 4 $\frac{1}{2}$ " (124mm) dia, 1 $\frac{1}{4}$ " (45mm) thick to take 5/32" or $\frac{1}{4}$ " (4mm or 6mm) thick cutters.

QR.105

2 knife wedge type, 4 $\frac{1}{2}$ " (124mm) x 1 $\frac{1}{4}$ " (45mm) thick, fitted with spur cutters to take one pair 5/32" or $\frac{1}{4}$ " (4mm or 6mm) thick cutters.

QR.112

2 knife wedge type, 4 $\frac{1}{2}$ " x 1 $\frac{1}{4}$ " (124mm x 24mm) thick to take cutters 5/32" or $\frac{1}{4}$ " (4mm or 6mm) thick.

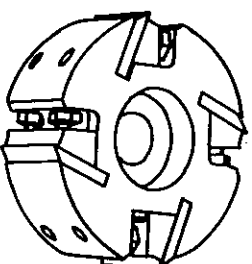
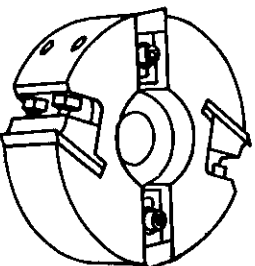
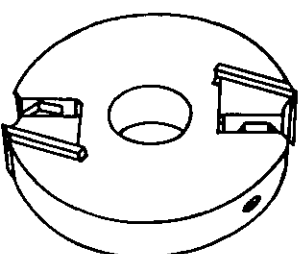

Q.T.37
Spanner and Locknut is required for cutterblocks QR.100 and QR.105 (one only needed per machine).

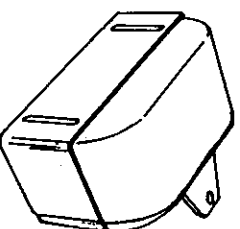

Guard for use with the above cutterblocks.

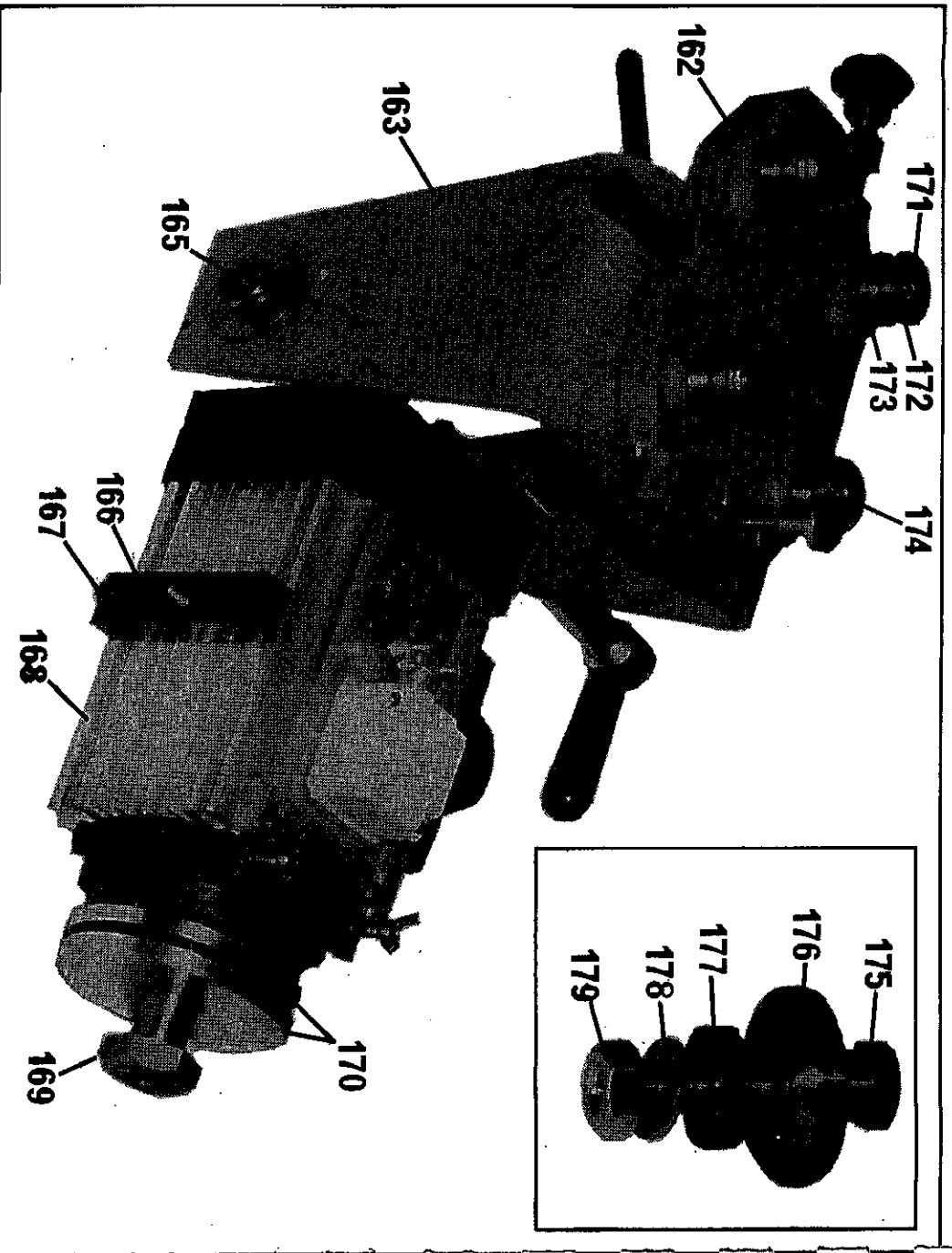

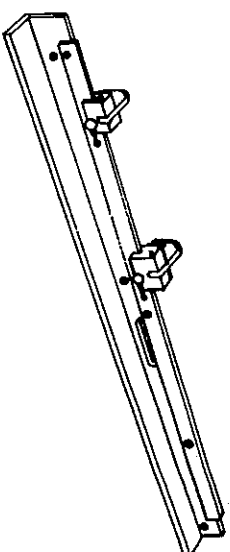
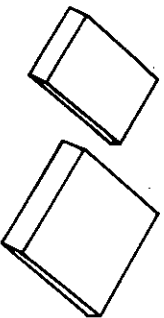

SQUARE EDGE CUTTERS FOR ABOVE CUTTERBLOCKS,

TYPE VZ
5/32" x 1 1/2" long.

Solid High Speed Steel.

Width on cut Part No.	1"	1 1/2"	1 3/4"	2"
VZ	VZ1	VZ2	VZ3	VZ4
				VZ5

Tungsten Carbide Tipped

Width on cut Part No.	1"	1 1/4"	1 1/2"	1 3/4"	2"
VZ/T	VZ1/T	VZ2/T	VZ3/T	VZ4/T	VZ5/T

1/4" thick x 1/2" long

High Speed Steel Welded to Mild Steel

Width on cut Part No.	1"	1 1/4"	1 1/2"	1 3/4"	2"
VZ20	VZ21	VZ22	VZ23	VZ24	VZ25

Tungsten Carbide Tipped

Width on cut Part No.	1 1/4"	1 1/2"
VZ22/T	VZ23/T	

Sold High Speed Steel in the bar: 5/32" thick,
3/4", 1", 1 1/4", 1 1/2", 1 3/4", 2", 2 1/4", 2 3/4", 3" wide.
High Speed Steel Welded to Mild Steel: 3/4" thick,
3/4", 1", 1 1/4", 1 1/2", 2" wide.

Adjustable metal fence with stop bar for cutting off material up to 3 1/6" (1067mm) long complete with two adjustable turn over stops for repetition work.
Longer stop bars can be supplied to special order, to give capacities 6ft, 9ft and 12ft (1,828mm, 2,743mm and 3,658mm). Maximum graduation is 6ft. (1828mm) on any bar supplied.

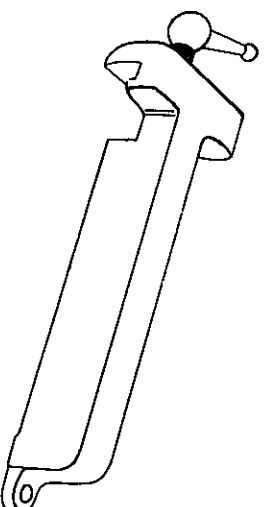

Adjustable stop for multiple crosscutting designed to drop onto the stop bar shown above.

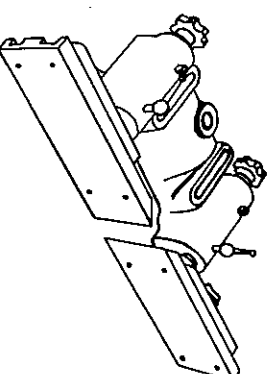

Horse shoe fence for use when moulding, routing, etc.

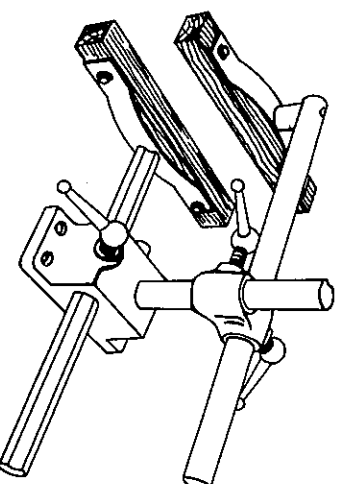
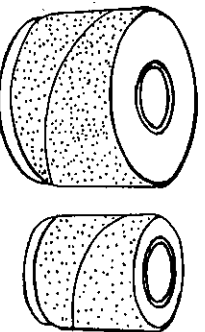

SANDING BOBBINS

These bobbins consist of four circular rubber sections each 1/2" thick mounted on a sleeve, with a steel flange at each end, and carrying spirally wound aluminium oxide cloth belts, grade O-80 or grade 1-50. Two sizes available, 2" diameter x 2" deep, 3" diameter x 2" deep.

Saw type guard for use with fences when moulding, etc.

Metal roller table 77" (1955mm) long and 12" (305mm) wide complete with graduated stop bar can be supplied for use in either side of the machine. The illustration on page 16 shows a table fitted to the left of the machine. When ordering please state which side of the machine the table is to be fitted for purpose of the graduated stop bar.

Capacity of table is 8ft. (2438mm) to the left of the saw and 9ft. (2740mm) to the right of the saw.

APPLICATIONS

There is a place in every woodworking shop for this versatile machine. The saw unit rotates horizontally through 360° and fits to any angle from horizontal to vertical; it can be locked in any position along the arm which swings 45° either way. Thus by simple, quick and positive movements the saw can be arranged to do crosscutting, bevel crosscutting, mitring, compound angle cutting, ripping and bevel ripping to a maximum of 4½" (114 mm) cut. In addition by fitting dado or trenching heads, cutterblocks, moulding blocks etc, an almost unlimited variety of operations are possible - even disc and bobbin sanding can be done with this extremely versatile machine.

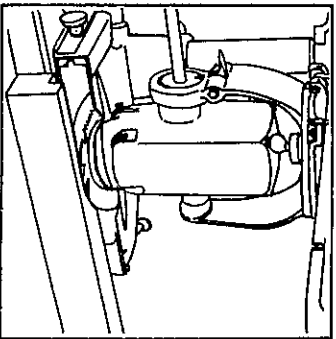

REBATING WITH DADO HEAD.

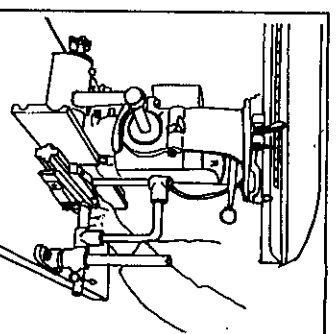

MOULDING WITH CIRCULAR CUTTERBLOCK.

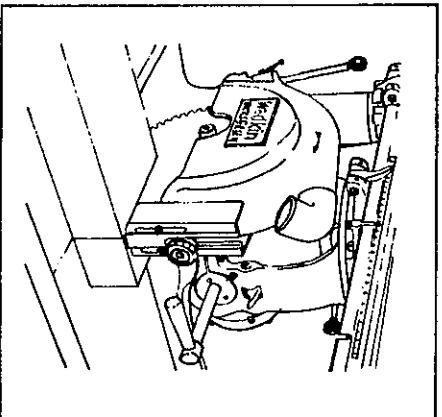

CROSSCUTTING.

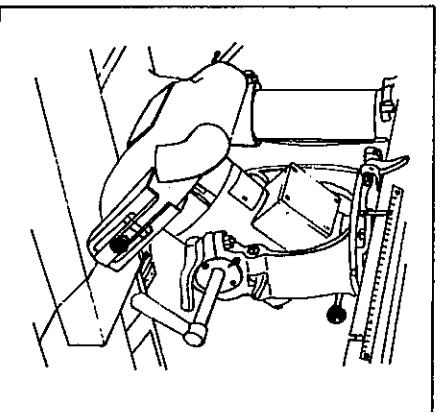

BEVEL CROSSCUTTING.

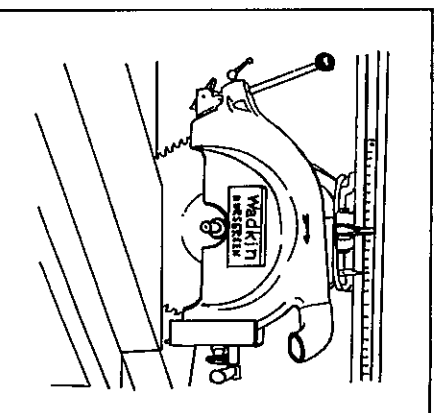

MITRING.

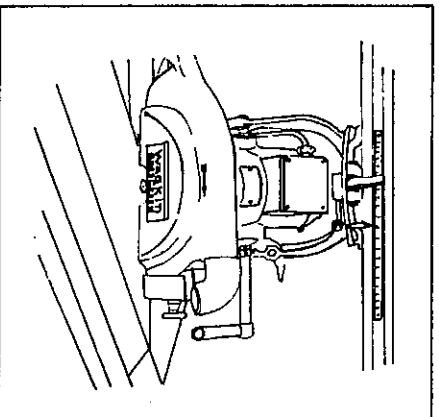

COMPOUND MITRING.

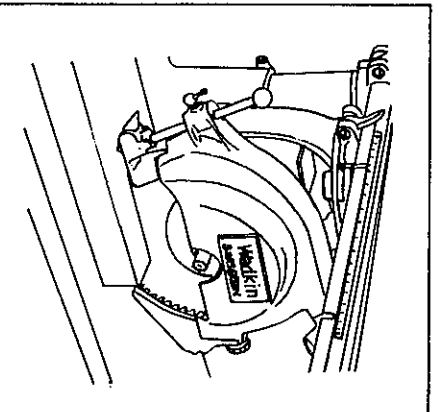

STRAIGHT RIPPING.

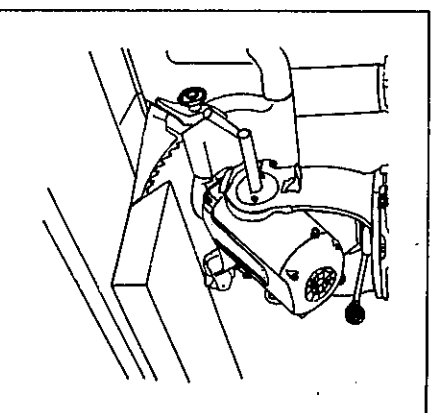

BEVEL RIPPING.

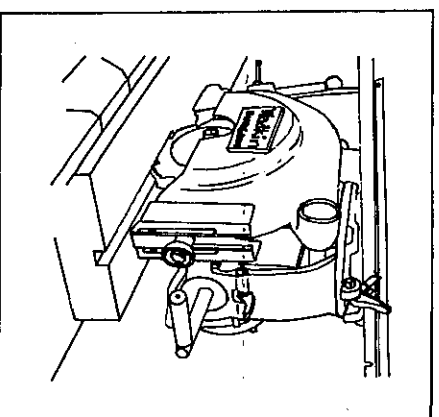

PLOUGHING WITH DADO HEAD.

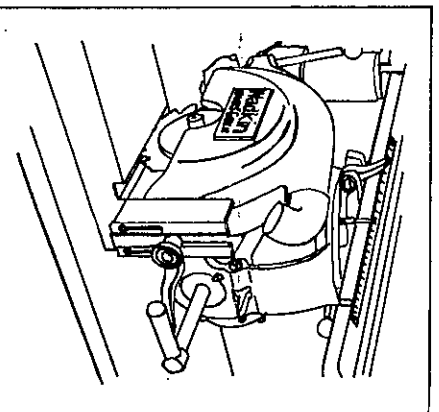

GROOVING WITH DADO HEAD.

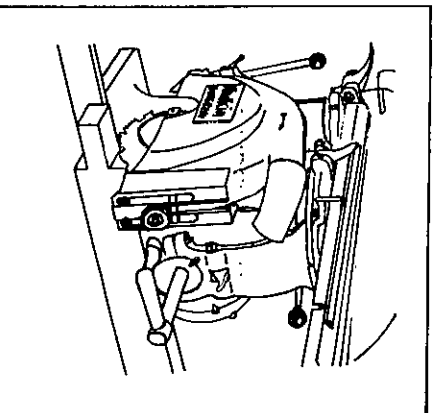

TENONING WITH DADO HEAD.

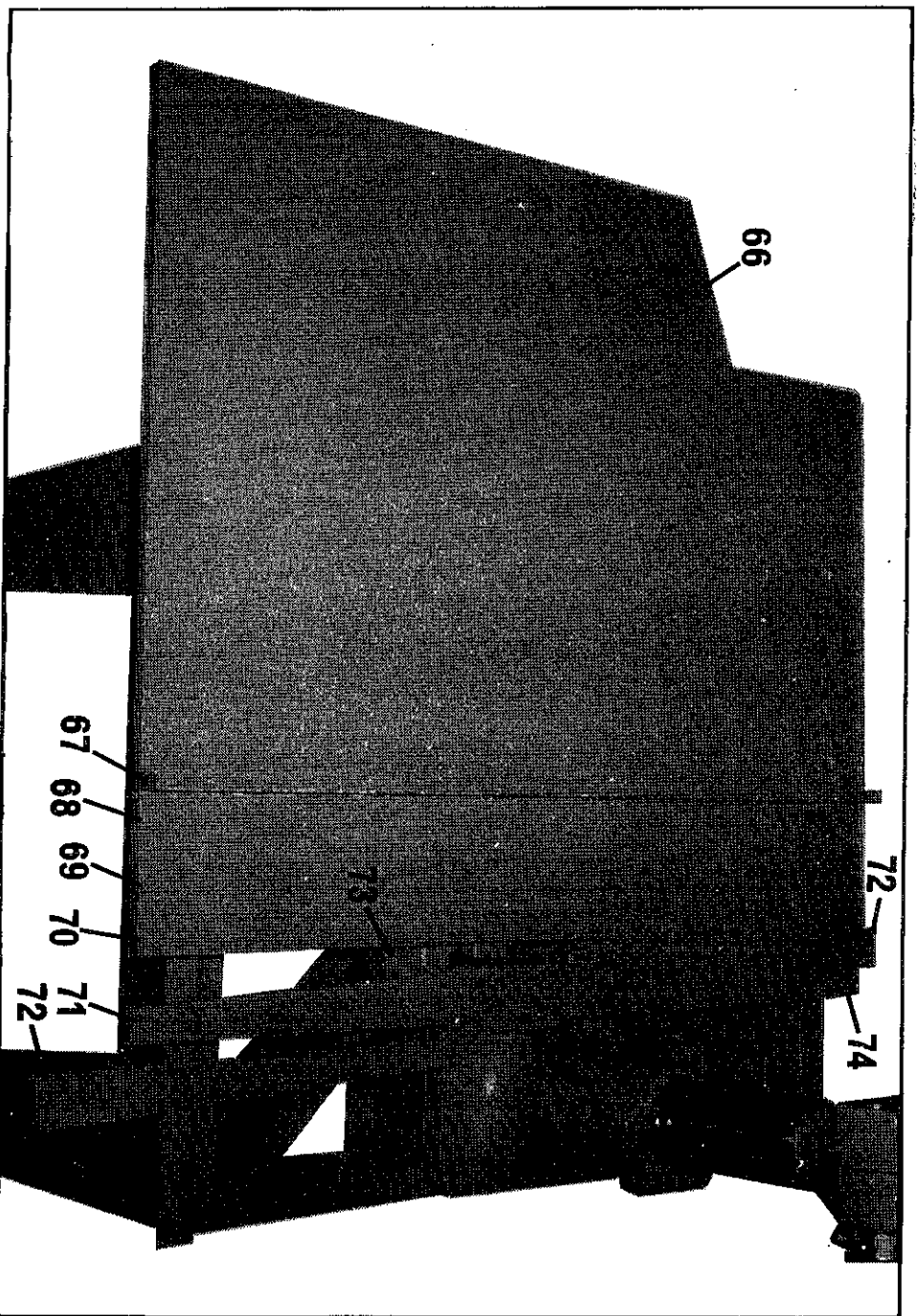
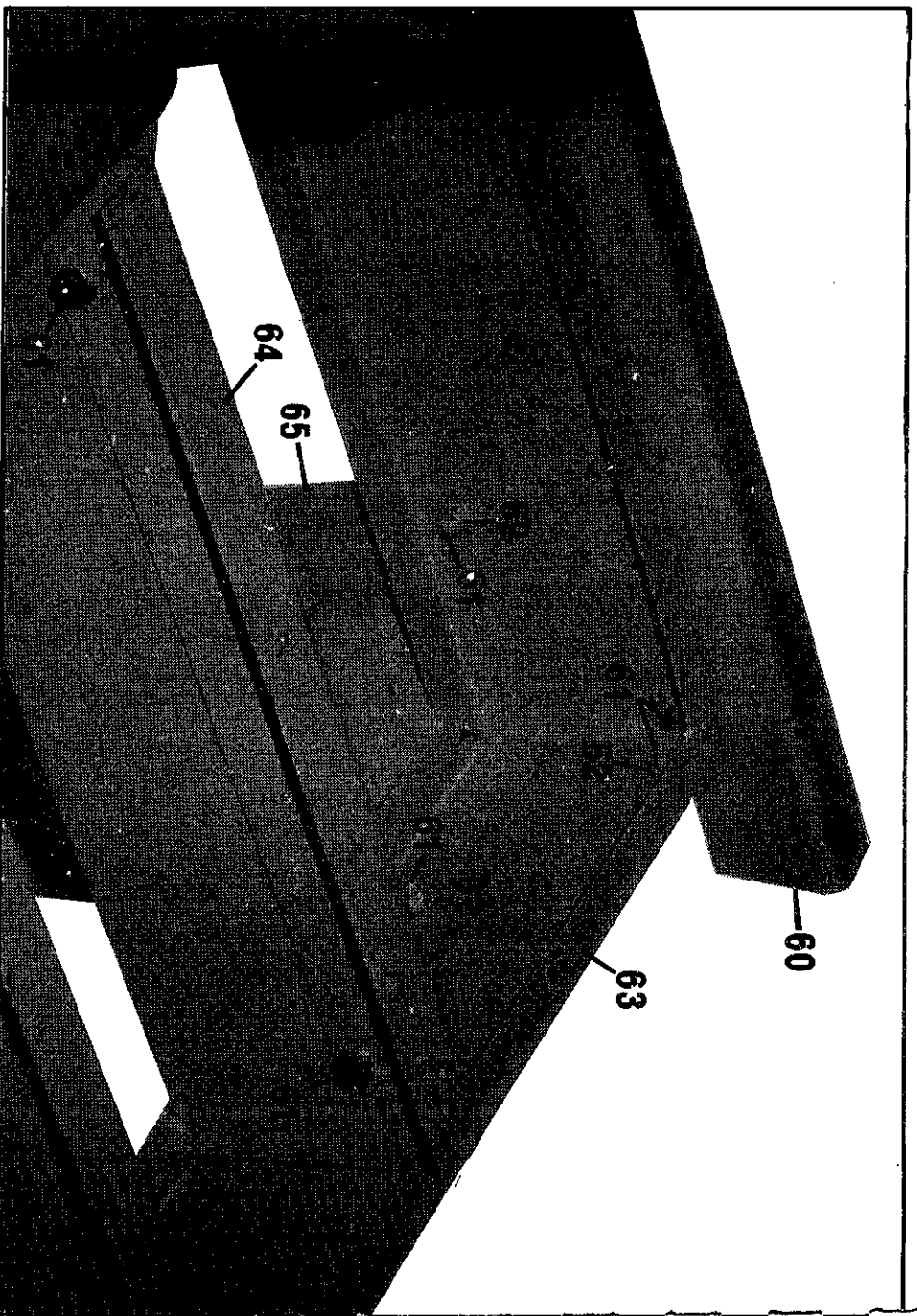

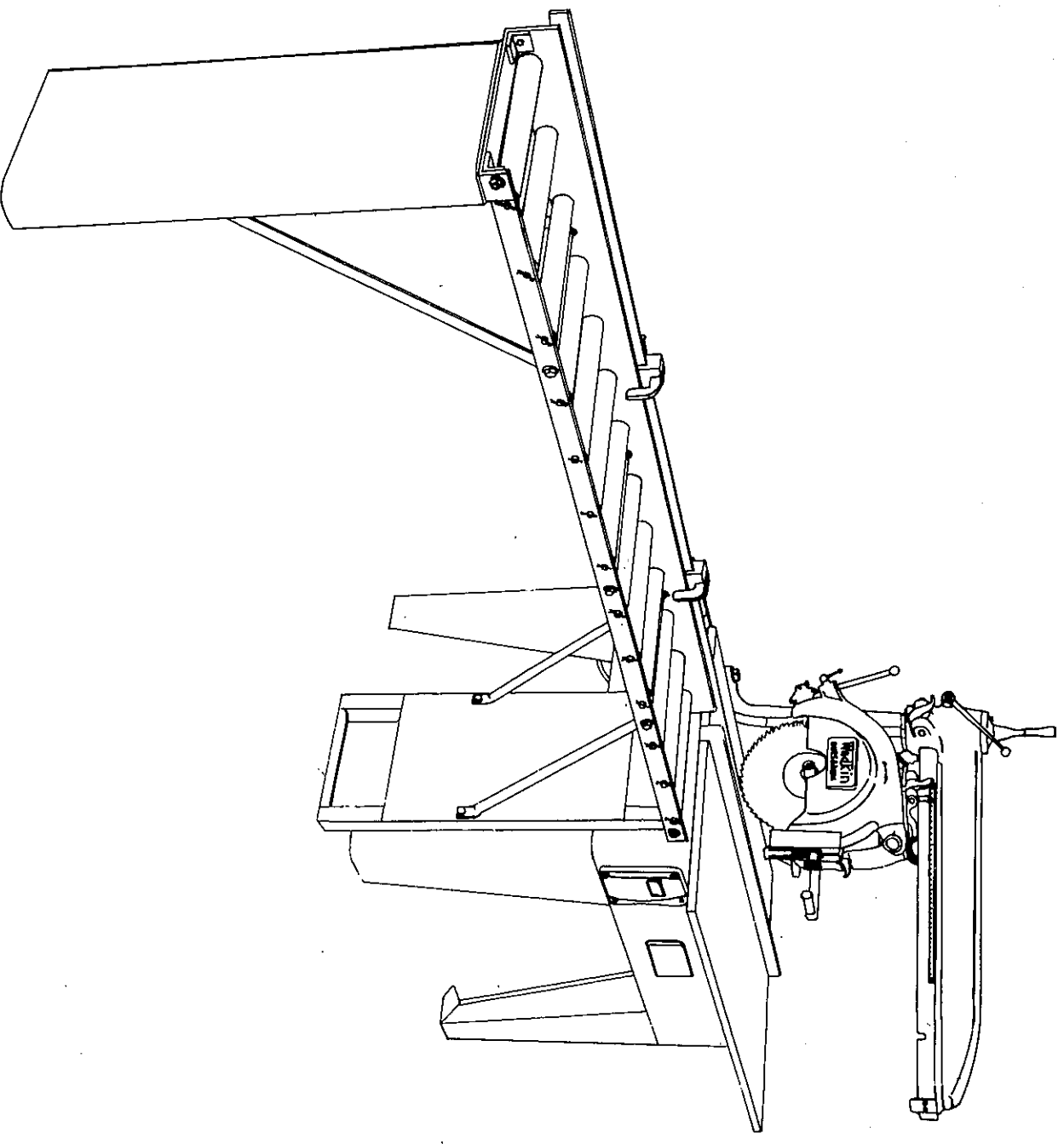

METAL ROLLER TABLE FITTED TO THE LEFT OF THE SAW TO GIVE A MAX^M OF 8 FT (2438MM). WHEN FITTED TO THE RIGHT IT GIVES A MAX^M OF 9 FT (2743MM).

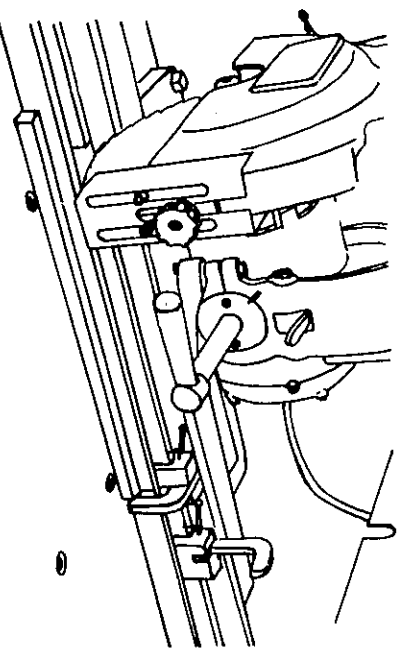

CROSSCUTTING USING TURNOVER STOP & METAL FENCE FOR REPETITION WORK.

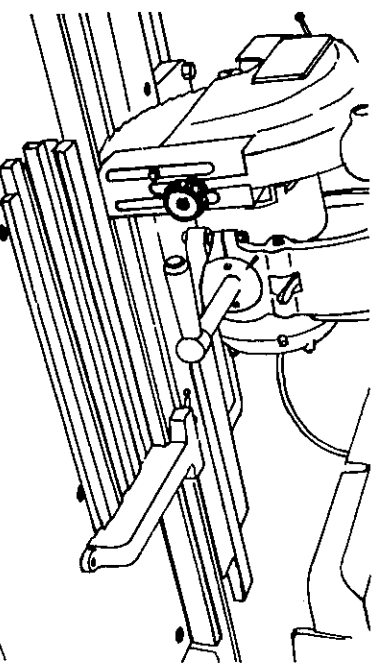

MULTIPLE CROSSCUTTING USING METAL FENCE AND SPECIAL STOP WHICH CAN BE READILY FITTED TO THE STOP BAR.

THE ILLUSTRATED JOINTS CAN BE READILY DONE ON THIS MACHINE, SOME MAY REQUIRE SIMPLE JIGS.

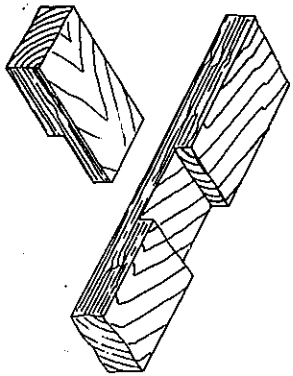

TEE HALF LAP

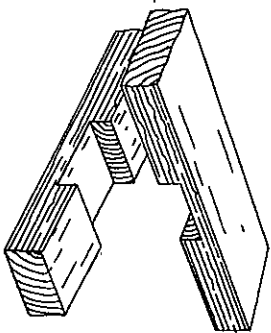

MIDDLE HALF LAP

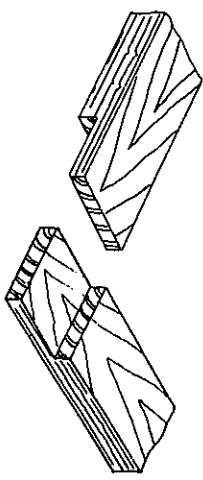

END HALF LAP

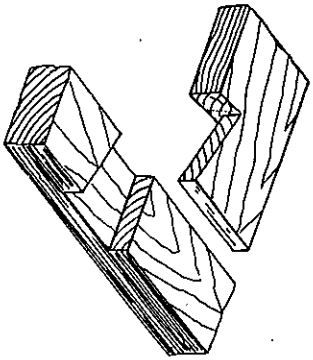

DOVETAIL HALF LAP
(ONE SIDE ONLY)

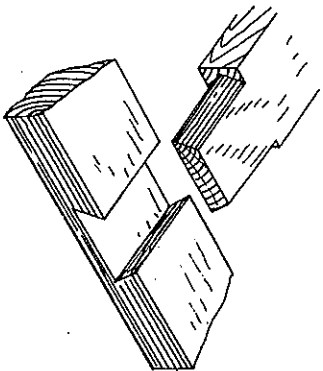

DOVETAIL HALF LAP

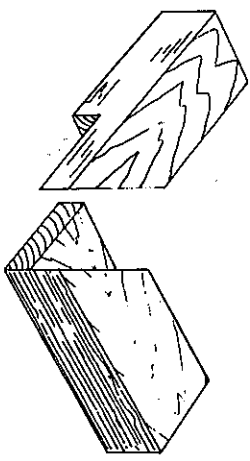

MITRED FACE WITH HALF LAP

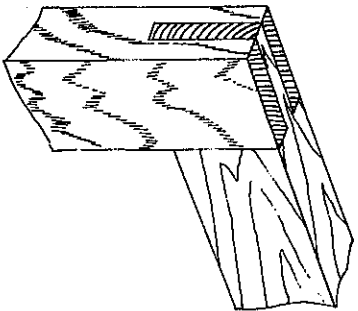

OPEN MORTISE & TENON

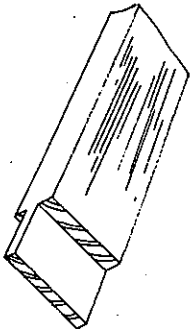

TENONS

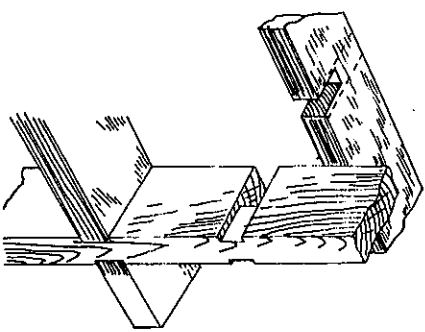

LAPPED JOINT WITH GROOVE
(USEFUL FOR SHELVING)

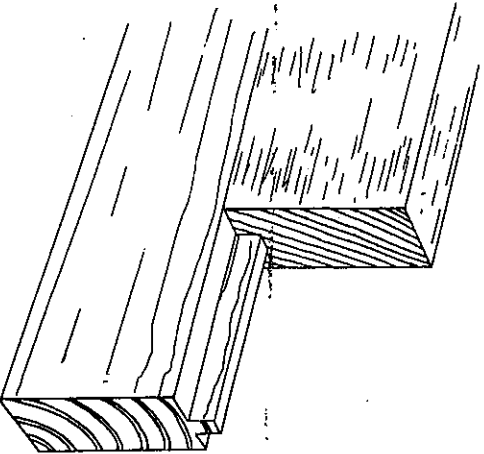

TONGUE & GROOVE

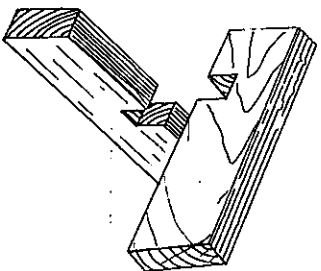

MIDDLE HALF LAP

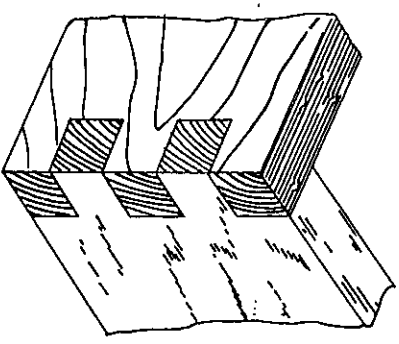

BOX JOINT

