

A WADKIN-DOMINION PRODUCT

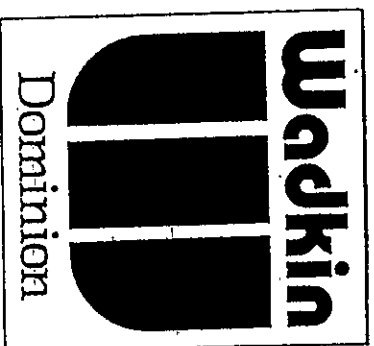

INDEX

PAGE	
1 / 2	HEALTH & SAFETY ADVICE
3	GENERAL SAFETY NOTES
4	LIFTING
5	FOUNDATION
6	KK CROSSCUT - DIAGRAM
7	KK CROSSCUT
8	CONTROL PANEL
9	SAFETY FEATURES
10	SAWSETTING AND REMOVAL - DIAGRAM
11	SAWSETTING AND REMOVAL
12	DRIVE DETAILS
13	SAW SPINDLE FRAME
14/15	OPERATING THE MACHINE
16	SAW CHANGE
17	TABLES AND STOPS
18/19	REPLACEMENT PARTS LIST
20	PNEUMATIC DIAGRAM
21	WIRING DIAGRAM
22	LAYOUT DRAWING
23	LUBRICANTS
24	TECHNICAL INFORMATION

HEALTH AND SAFETY ADVICE

Persons who install this machine for use at work have a duty under the Health and Safety at Work etc. Act 1974 to ensure, so far as is reasonably practicable, that nothing about the way in which it is installed makes it unsafe or a risk to health at all times during setting, use, cleaning and maintenance. This includes such aspects as correct assembly, electrical installation, construction of enclosures, fitting of guards and exhaust ventilating equipment. When installing this machine, consideration must be given to the provision of adequate lighting and working space.

This machine is supplied complete with all necessary safeguards to enable the user to comply with the Woodworking Machines Regulations 1974. Details of correct installation and use, together with guidance on fitting and proper adjustment of guards are described in this manual.

The Woodworking Machines Regulations place absolute legal duty on employers and employees to ensure that guards and any other safety devices are securely fitted, correctly adjusted and properly maintained.

Repairs and maintenance must only be undertaken by competent technicians. Ensure that all power supplies are isolated before maintenance work commences. Instructions for routine maintenance are included in this manual.

Machine operators must have received sufficient training and instructions as to the dangers arising in connection with the machine, the precautions to be observed and the requirements of the Woodworking Machines Regulations which apply, except where they work under the adequate supervision of a person who has a thorough knowledge and experience of the machine and the required safeguards.

Persons under the age of eighteen years must have successfully completed an approved course of training before operating this machine at work, unless participating in a course of training under adequate supervision. (N.B. This paragraph is only relevant to: circular sawing machines, any sawing machine fitted with a circular blade, any planing machine for surfacing which is not mechanically fed or any vertical spindle moulding machine).

Before commencing work, ensure that the tooling is set to cut in the correct direction, securely fastened, sharp and is compatible with the machine and spindle speed.

DUST

Wood dust can be harmful to health by inhalation and skin contact and concentrations of small dust particles in the air can form an

explosive mixture. These concentrations usually occur in dust extraction equipment which may be destroyed unless explosion precautions have been taken in the design and installation of the equipment.

Employers have duties under the Factories Act 1961, the Health and Safety at Work etc. Act 1974 and the Control of Substances Hazardous to Health Regulations 1988 to control wood dust in the workplace.

Employers should carry out an adequate assessment of the possible risks to health associated with wood dust to enable a valid decision to be made about the measures necessary to control the dust. It may be necessary to provide effective exhaust appliances.

Prevention or control of wood dust exposure should, so far as is reasonably practicable, be achieved by measures OTHER than the provision of personal protective equipment.

Further information and references to practical guidance are contained in free leaflets available from the Health and Safety Executive.

NOISE

Noise levels can vary widely from machine to machine depending on conditions of use. Persons exposed to high noise levels, even for a short time, may experience temporary partial hearing loss and continuous exposure to high levels can result in permanent hearing damage. The Woodworking Machines Regulations require employers to take reasonable practicable measures to reduce noise levels where any person is likely to be exposed to a continuous equivalent noise level of 90 dB(A) or more over an 8 hour working day. Additionally, suitable ear protectors must be provided, maintained and worn.

Machines identified as generating unhealthy noise levels should be appropriately marked with a warning of the need to wear hearing protection and it may be necessary to designate particular areas of the workplace as "Ear protection zones". Suitable warning signs are specified in the Safety Signs Regulations 1980. It may be necessary to construct a suitable noise enclosure, in which case professional advice should be sought.

Further information and references to practical guidance are contained in free leaflets available from Health and Safety Executive.

GENERAL SAFETY NOTE

The enclosed operating instructions draw particular attention to the legal requirements of the U.K. Health & Safety Laws. Whilst safety laws vary in the many different countries to which Dominion machines are exported, the advice and obligations which are mandatory in the United Kingdom should be equally observed elsewhere in the world. Woodworking machines are potentially dangerous in untrained hands and must not be entrusted to such operators.

"Familiarity breeds contempt", and many accidents are caused, even to skilled operators, when they become familiar with machinery. DO NOT TAKE SHORT CUTS. Always use the guards provided and observe the warning labels.

When cleaning and setting this machine, do not forget that Saw Teeth are dangerous even when the Saw is stationary. Avoid contact with Saw Teeth at all times when installing the saw in the machine.

The K.K. is designed for two handed operation to ensure the operators hands are kept remote from the saw. It is imperative to ensure that no other personnel are permitted anywhere near the machine or guards during the operating cycle.

LIFTING

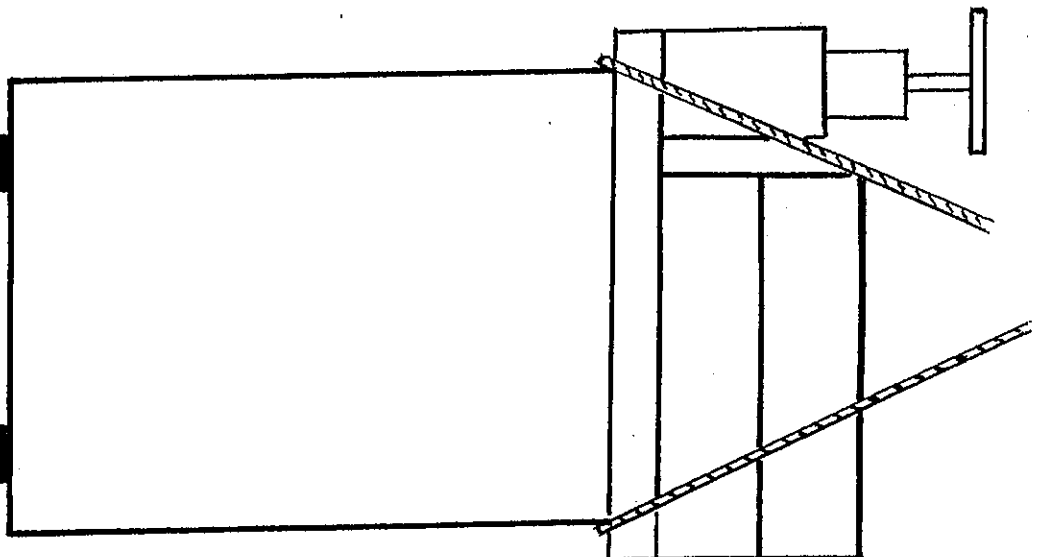

Weight 362 Kg.

Lift by slings placed
under edge of table
or Fork lift as shown

LIFTING BY SLING

USE A SLING WITH A SAFE WORKING LOAD IN EXCESS OF THE MACHINE WEIGHT - i.e. 362 kgs. ALLOW FOR SOME ADDITIONAL WEIGHT WHICH MAY RESULT FROM EXTRA ITEMS ORDERED WITH THE MACHINE, TOGETHER WITH THE WEIGHT OF PACKAGING.

I M P O R T A N T

DO NOT WALK UNDER THE MACHINE OR PERMIT OTHER PEOPLE TO DO SO WHILST LIFTING.

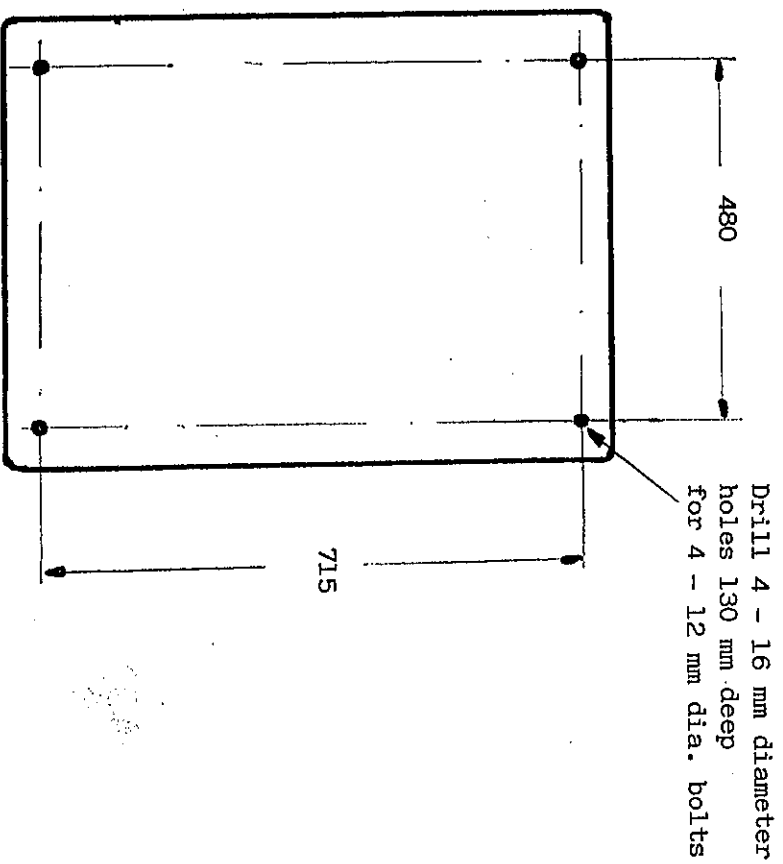
FOUNDATION

Machine must be positioned and levelled on a solid floor.

If sited close to a wall sufficient clearance must be available to allow for maintenance and the waste extraction to function correctly.

Waste extraction requirements $1\text{m}^3/\text{min}$.

K.K. CROSSCUT

K.K. WITH STANDARD AND ALTERNATIVE
POSITION FOR TWO HAND SAW CYCLE CONTROL.

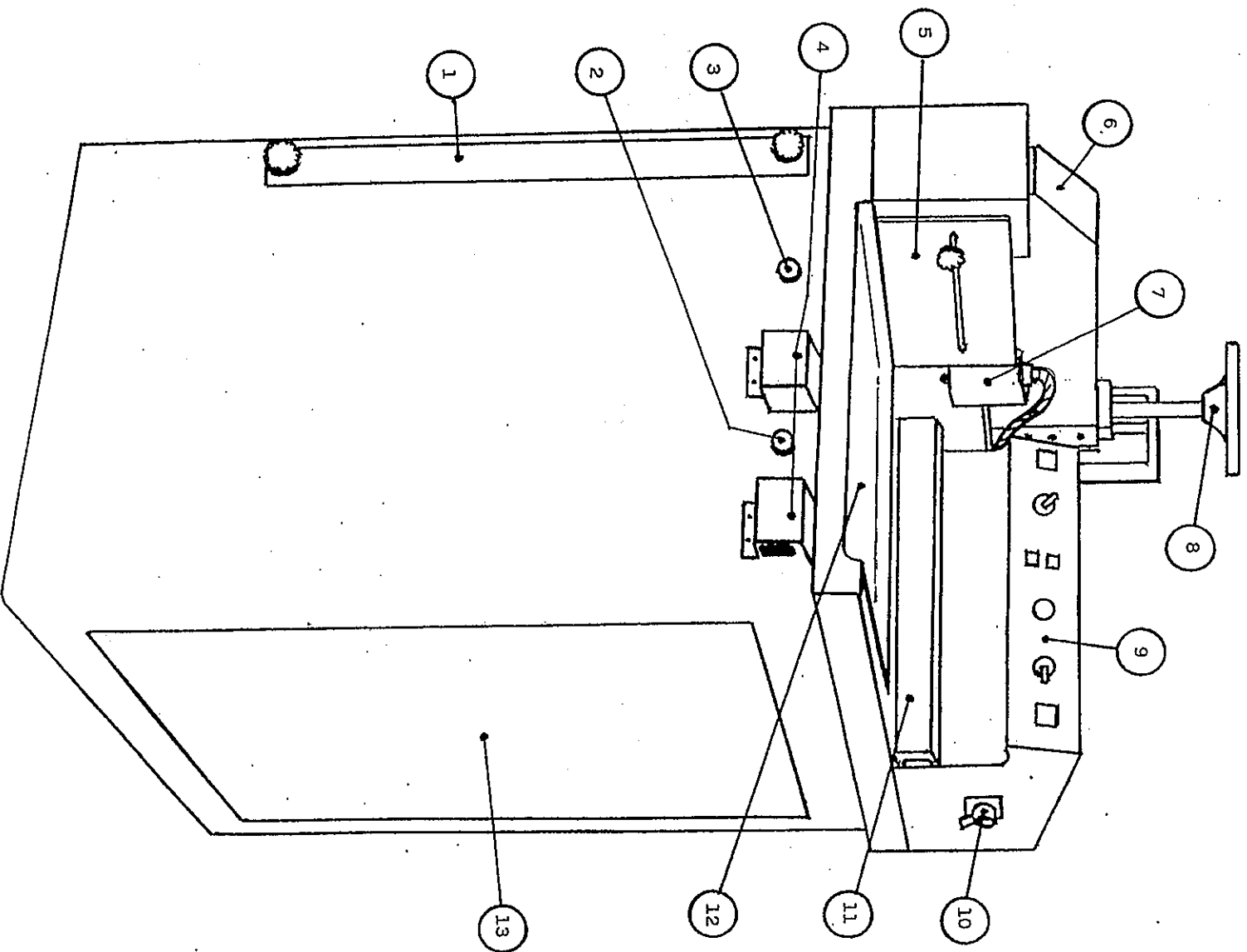

K.K. CROSSCUT

- 1 Cover over saw removal opening
- 2 Cutting cycle/up stroke adjustable controller
- 3 Cutting cycle/down stroke regulator (factory preset)
- 4 Alternative position for two hand saw cycle controls
- 5 Adjustable side guard
- 6 Top clamp
- 7 Micro Switch
- 8 Handwheel for top clamp adjustment
- 9 Control console
- 10 Lockable Isolator
- 11 Fence
- 12 Table with comfort well
- 13 Access panel to:-

Motor and drive

Saw Spindle and Yoke

Pneumatic cylinder

Lubrication points

CONTROL PANEL

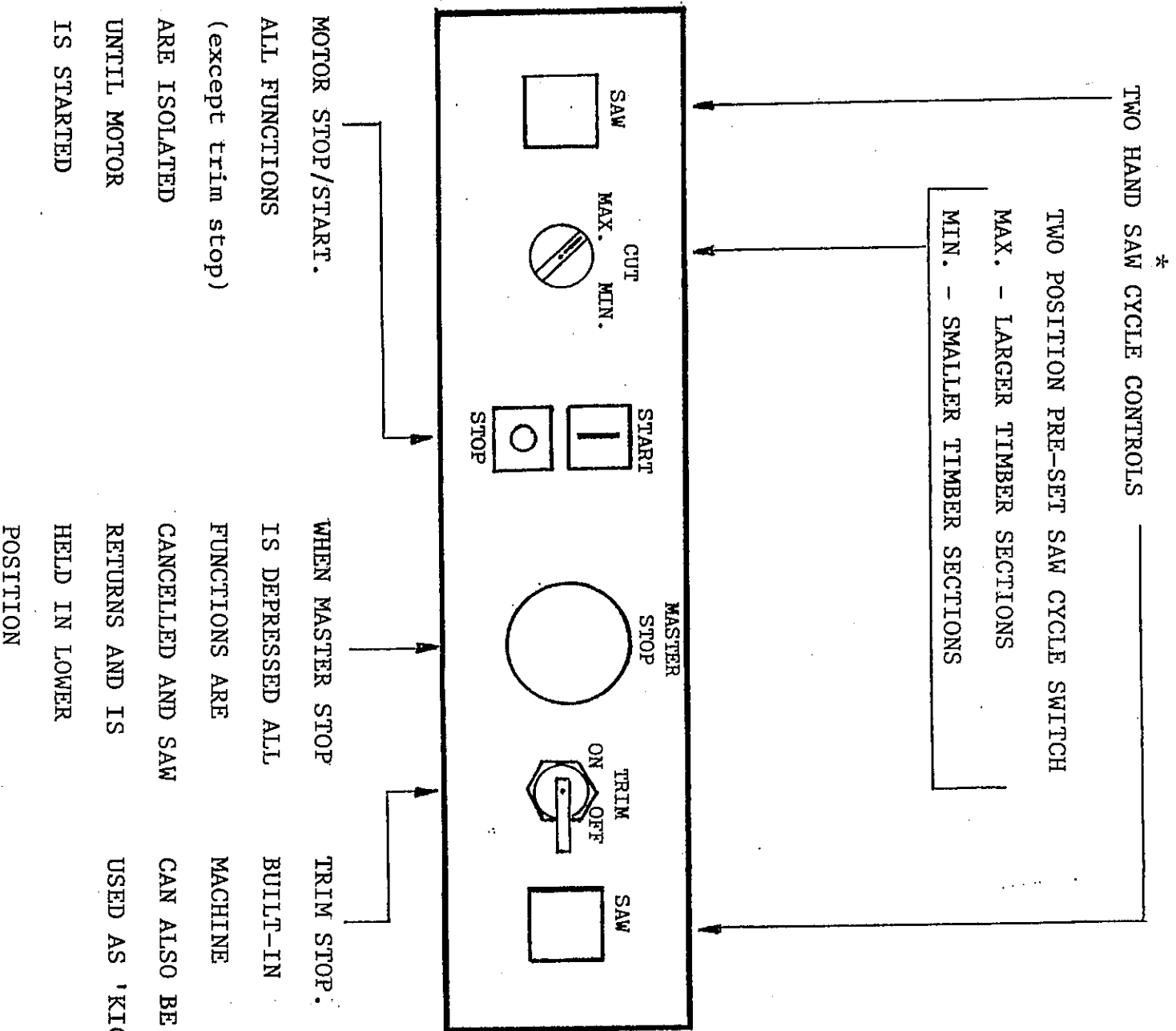

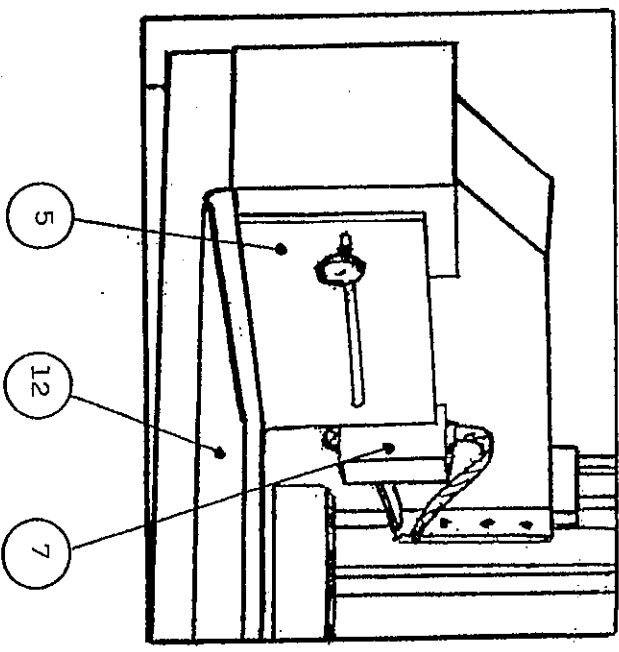
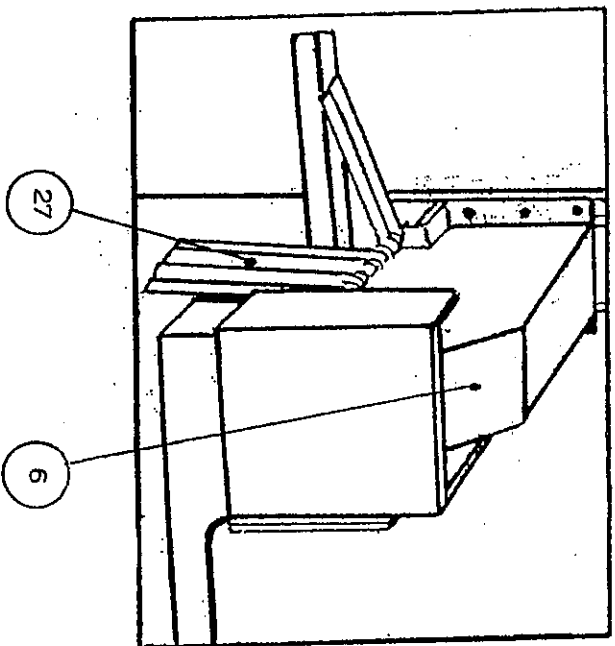
SAFETY FEATURES

Micro Switch (7) must be actuated before operating cycle can be completed.

Main motor must be energised before cutting sequence is operative.

Guards (5 & 27) either side of top clamp (6) shroud saw with timber in position.

"Comfort Well" in table (12) assist handling.

N.B. Trailing finger outfeed guard (27) will be replaced by a mesh tunnel on certain applications.

SAM SETTING AND REMOVAL

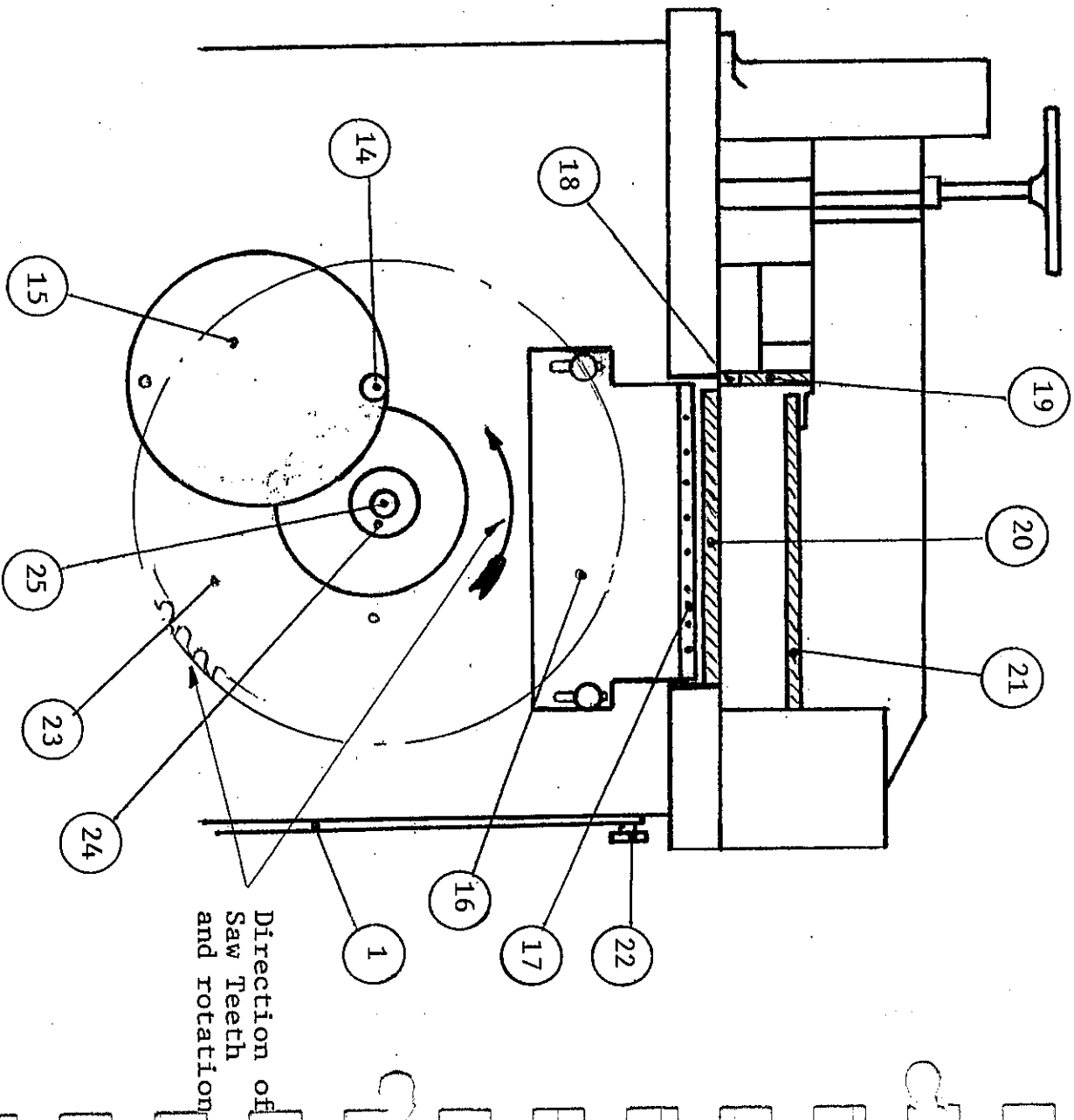

SAW SETTING AND REMOVAL

- 14 Handwheel (two) for positioning cover (15)
- 15 Cover access for saw removal
- 16 Saw Guard
- 17 Saw Guard Lip
- 18 Trim Stop
- 19 H.D.F. replaceable facing
- 20 H.D.F. replaceable saw plate
- 21 H.D.F. facing for top clamp
- 22 Handwheel (two) for positioning saw exit cover (1)
- 1 Saw exit cover
- 23 Saw
- 24 Front Saw Collar
- 25 Saw Collar locating screw

H.D.F. is High Density
Fibre Board

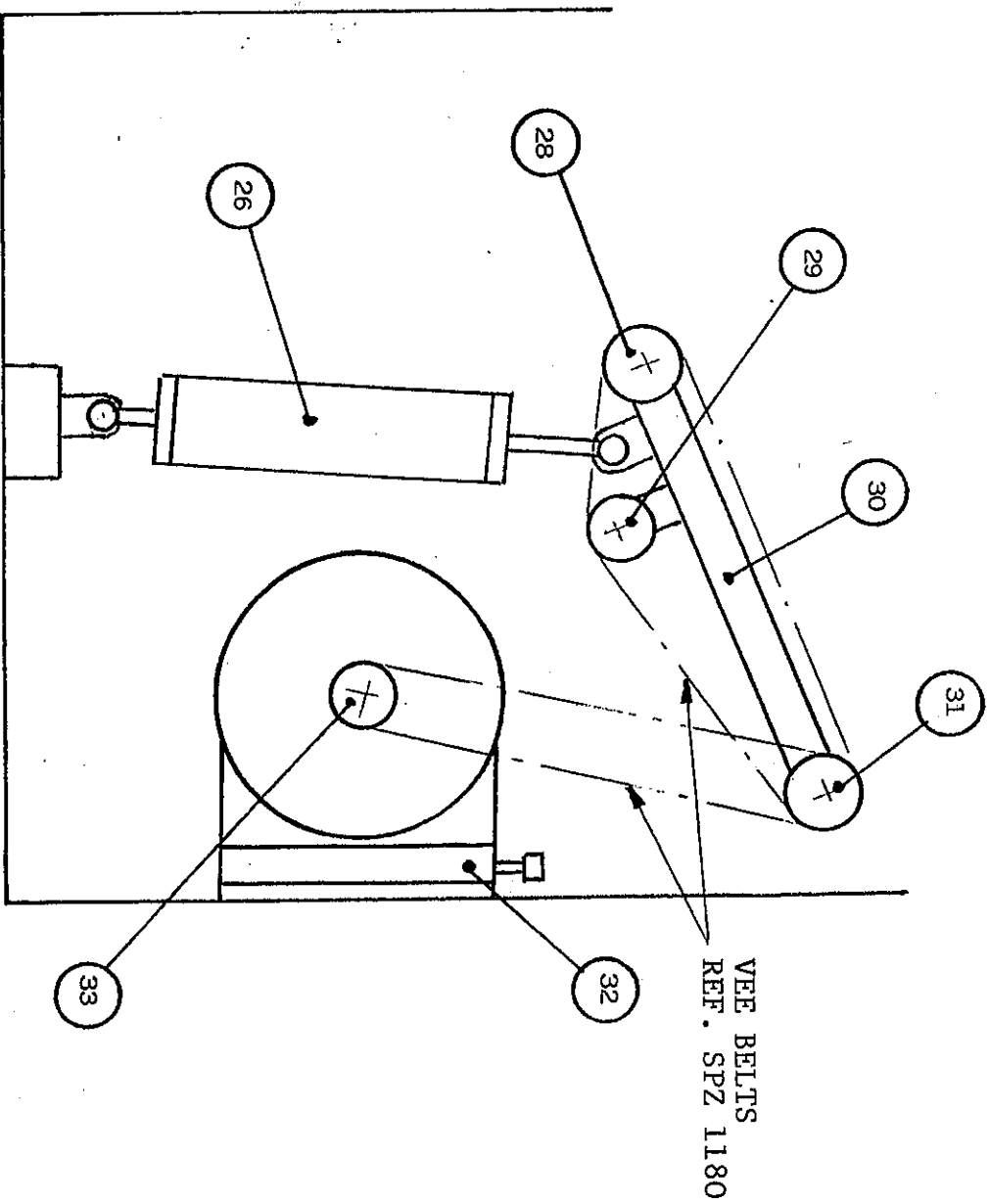
DRIVE DETAILS

- 26 Saw Cycle Cylinder
- 28 Saw Spindle V Pulley
- 29 Tightener Pulley
- 30 Saw Spindle Frame
- 31 Driven V Pulley
- 32 Motor V Belt Tensioning Bracket
- 33 Motor V Pulley

SAW SPINDLE FRAME

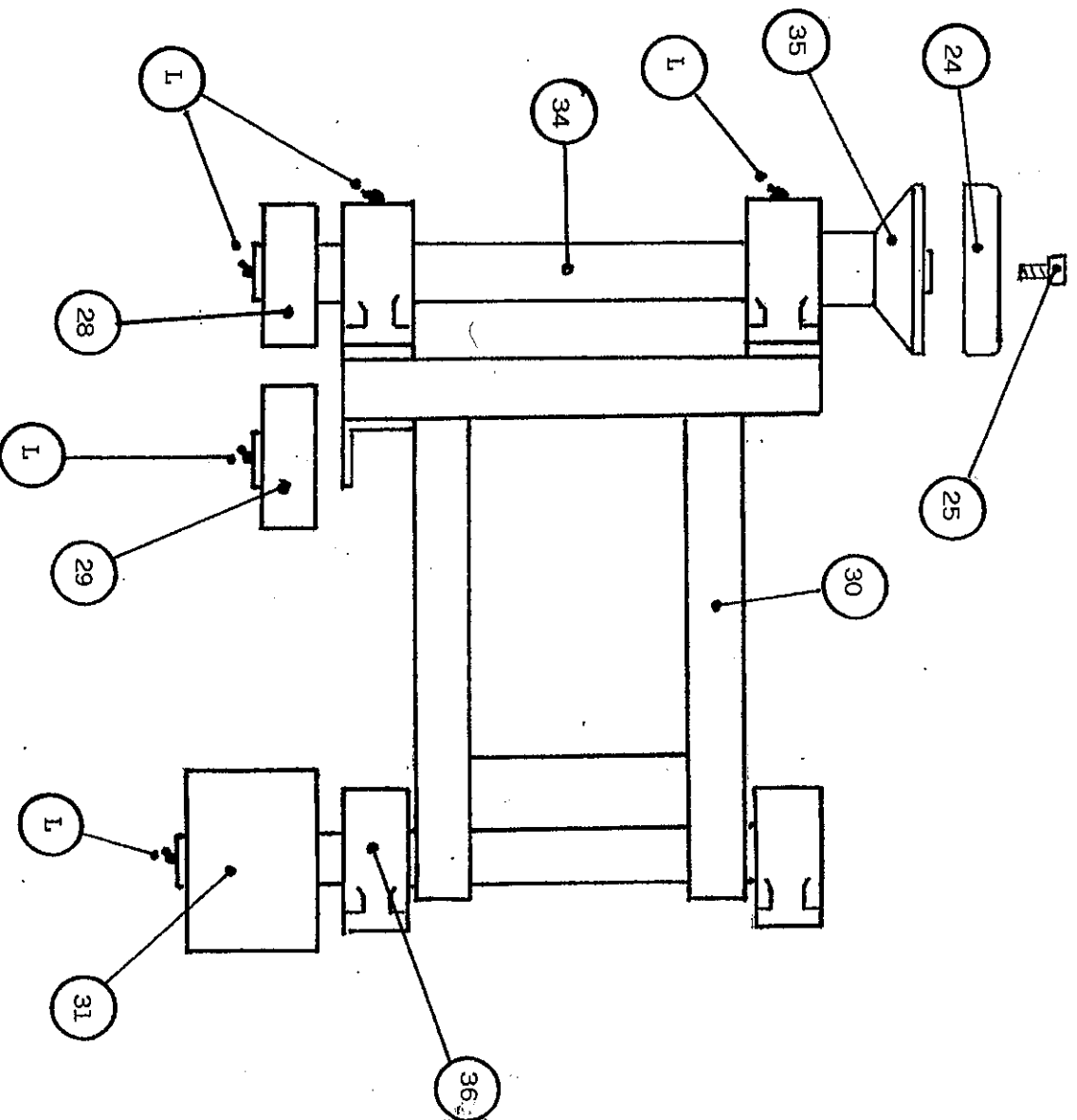

- 28 Saw Spindle V Pulley
- 29 Tightener Pulley
- 30 Saw Spindle Frame
- 31 Idler V Pulley
- 34 Saw Spindle
- 35 Rear Saw Collar
- 24 Front Saw Collar
- 25 Saw Collar Locking Screw
- 36 Ball Bearing Housing 4 - off
- L Lubrication Points - top up monthly with 2 strokes only of Grease Gun

OPERATING THE MACHINE

FIRST

Ensure that the machine is correctly connected to the electrical, pneumatic and dust extraction supply.

Check saw rotation is anti-clockwise (cutting towards the Fence).

SETTING

Position the timber in the machine ready for cutting.

Set the Infeed adjustable guard to within 5 mm of timber.

Outfeed guard, whether it be the Trailing Finger or Tunnel type requires no adjustment.

Lower the top guard/clamp to within 5 mm of timber. This ensures that the Micro Switch comes into contact with the timber when the guard/clamp is automatically lowered during the operating sequence.

Switch on electric, air and extraction supply.

Switch Isolator to 'On' and 'Start' main motor.

N.B. other functions are isolated until main motor is running at full speed.

Actuate the two hand control buttons simultaneously (these can be positioned on the control console or to the base).

This action first lowers the top guard to clamp the timber and second, triggers the upcutting saw which completes the cut and returns to the bottom position.

N.B. if the gap between the top guard/clamp and the timber is excessive and results in the timber not being clamped, the Micro Switch will remain open and the saw will remain in the lower position.

BY PRESSING THE MASTER STOP THE SYSTEM REVERTS TO NORMAL.

CUTTING CYCLE UPSTROKE ADJUSTABLE CONTROLLER (Page 6)

To cope with various types and sizes of timber the saw cycle control has variable adjustment to meet all needs.

In addition via the 'Cut' Control Switch one of two pre set cycle/speeds can be selected. The positions have been determined to provide instant change over when for example, cutting first 300 x 100 followed by

100 x 40 mm sections.

The Trim Stop can be actuated at will. This is set at 10 mm but is variable.

SAW CHANGE

- 1) Isolate machine at mains
- 2) Remove front access cover
- 3) Remove saw exit cover
- 4) Loosen saw collar locating screw (anti-clockwise) with key provided
- 5) Remove front saw collar
- 6) Saw can now be removed through saw exit opening

To assist saw removal, insert a piece of timber into the saw exit opening; the saw is protected and supported making removal easier and safer.

To fit new saw stops 1 to 6 should be followed in reverse order.

N.B. Care should be taken to ensure that the saw and saw collar faces are free from dirt before being fitted. Check the direction of the saw teeth before using.

(Page 10).

TABLES AND STOPS

Metal Fences with Manual or Pneumatically Actuated Stops can be supplied for connecting to Customers Tabling.

If supplied with Dominion Roller Tables the Metal Fence with Manual/Pneumatic Stops will be fitted to the Outfeed Table.

A plain Metal Fence can be supplied to fit on the Infeed Table.

When Roller Tables are provided with a machine, connecting brackets are supplied.

Roller Tables should be levelled to the machine with a straight edge.

When Pneumatic Stops and Kickers are supplied the connecting pipes are clearly identified.

Infeed and Outfeed Roller Tables are available in multiples of 2M.

REPLACEMENT PARTS LIST

Item No.	Page	Machines		
		feeding right to left Ref. No.	feeding left to right Ref. No.	
Cover over saw removal opening	1	6 & 10	19/M13	19/M13
Adjustable infeed saw guard	5	6 & 9	21/M13	21/M13
Top clamp	6	6 & 9	13/M13	43/M13
H.D.F. facings for top clamp	21	10	35/M13	BURGESS ML3151/L632
Micro Switch	7	6 & 10	BURGESS ML3151/L632	BURGESS ML3151/L632
Handwheel for top clamp adjustment	8	6	WDS178204	WDS178204
Screw for handwheel			KKS6	KKS6
Ball bearing thrust race for screw			RHP51104	RHP51104
Fence	11	6	14/M13	14/M13
Table	12	6 & 9	KK1	KK12
Access panel	13	6	18M/13	18M/13
Trailing finger outfeed guard (complete)	27	9	49 M/13	49 M/13
Cover	15	10	16M/13	16M/13
Saw guard	16	10	22M/13	22M/13
Saw guard lip	17	10	31M/13	31M/13
Trim stop (complete)	18	10	KKS10	KKS10
H.D.F. Facings	19	10	37M/13	36M/13
H.D.F. Sawplate	20	10	42/M13	41/M13
Handwheels	14 & 22	10	COATES HANDWHEEL 5714	COATES HANDWHEEL 5714

REPLACEMENT PARTS LIST - Continued

	Item No.	Page	Machines	Machines
			Feeding right to left	Feeding left to right
			Ref. No.	Ref. No.
Pneumatic cylinder (saw spindle frame)	28	12 & 13	RM 8063-200	RM 8063-200
Saw spindle vee pulley	29	12 & 13	KENYON TAPER LOCK 30Z95	KENYON TAPER LOCK 30Z95
Tightener pulley	29	12 & 13	KK6	KK6
Saw spindle frame	30	12 & 13	12/ML3	12/ML3
Idler vee pulley	31	12 & 13	KK5	KK5
Motor vee pulley	33	12	KENYON 30Z85	KENYON 30Z85
Vee Belts		12	SFZ1180	SFZ1180
Vee bolts tension bracket (motor plate)	32	12	KENYON MOTOR SIZE A	KENYON MOTOR SIZE A
Front saw collar	24	10 & 13	KK7/1	KK7/1
Rear saw collar	35	13	KK7	KK7
Saw collar locking screw	25	10 & 13	M16x40	M16x40
Saw spindle	34	13	KKSL	KKSL
Ball bearing housing 4 off	36	13	RHP SNP40	RHP SNP40
Dust protection brushes in base			32/ML3, 33/ML3	32/ML3, 33/ML3
Pneumatic cylinder (top clamp/guard)			RN8063-25	RN8063-25
<u>BALL BEARING LIST</u>				
Bearings for tightener pulley			RHP 6205-Z	RHP 6205-Z
Bearings for idler pulley			RHP 6207-Z	RHP 6205-Z

PNEUMATIC DIAGRAM

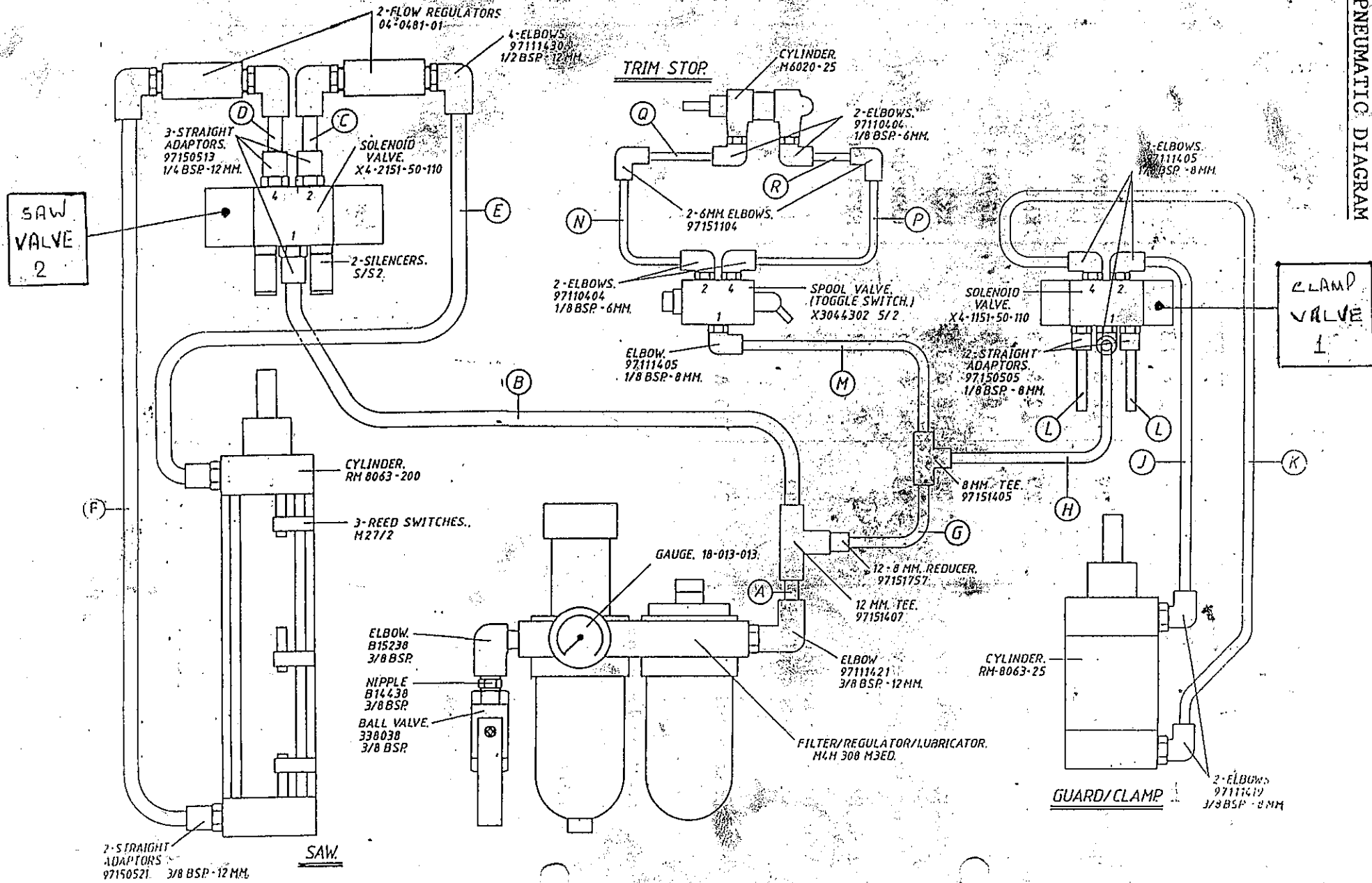

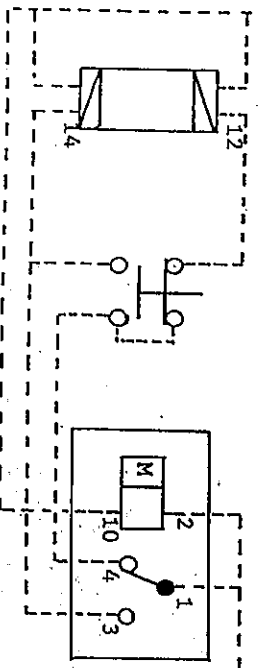
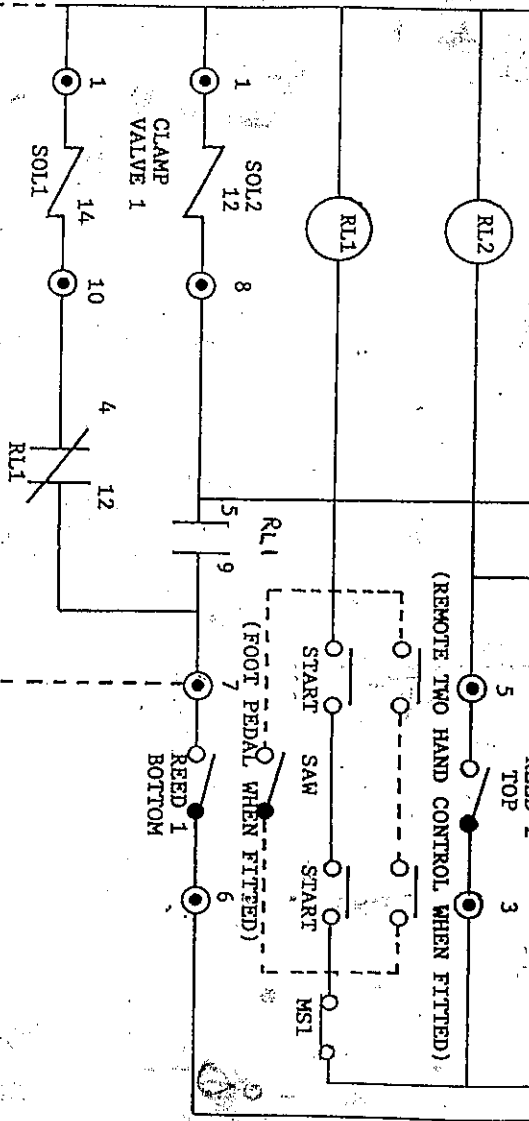
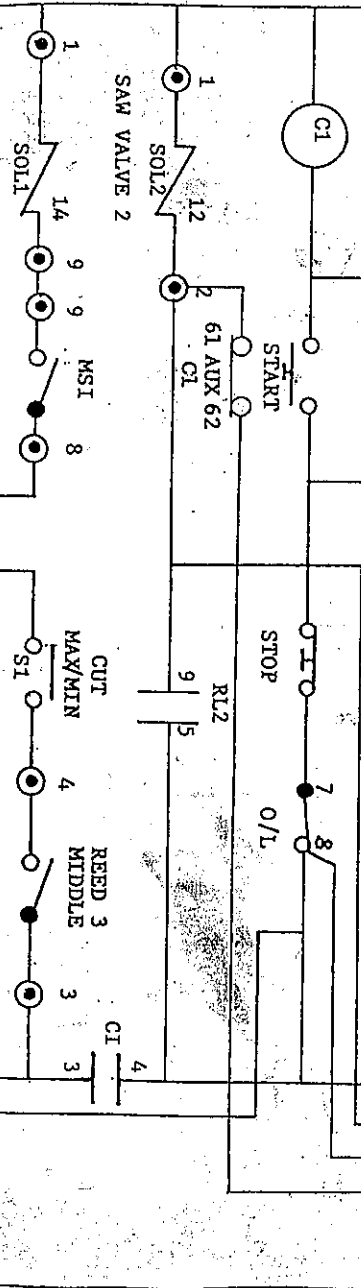
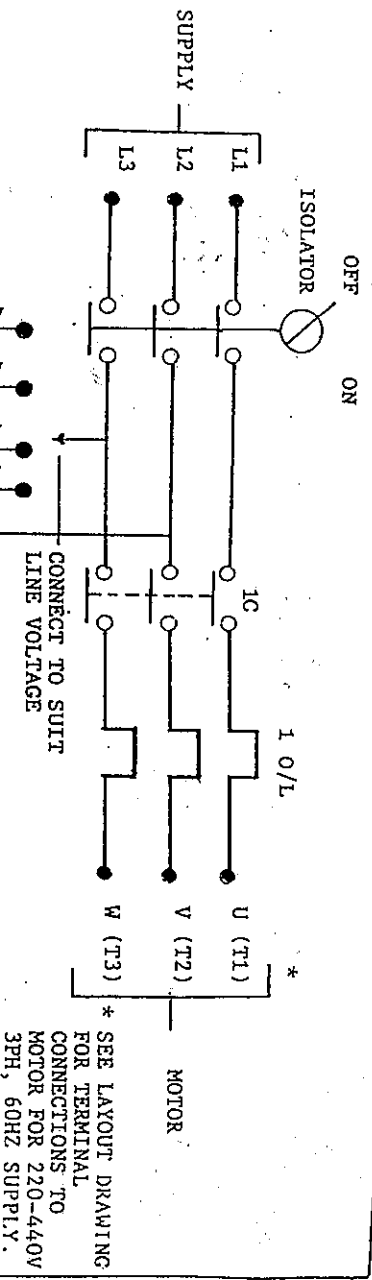

WIRING DIAGRAM

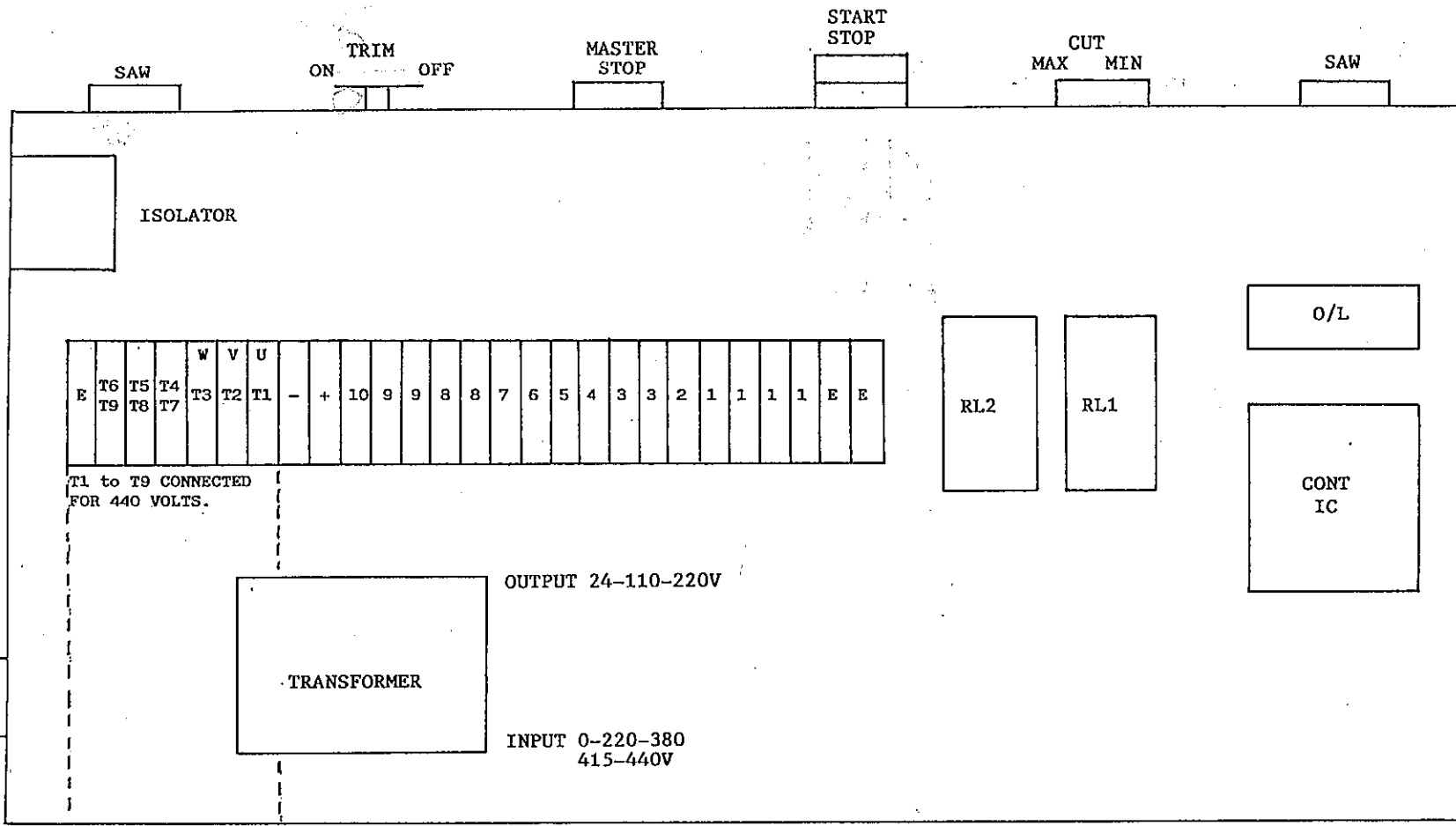

T1 to T9 CONNECTED FOR 440 VOLTS.

IMPORTANT (FOR MACHINES FITTED WITH 220-440 VOLTS, 3 PHASE, 60 CYCLES ELECTRICS)
 CHECK THAT MOTOR LEADS NUMBERED T1 TO T9 ARE CONNECTED TO SUIT THE MAINS VOLTAGE SUPPLY.
 CHECK THAT THE CORRECT TAPPING ON THE TRANSFORMER HAS BEEN SELECTED TO SUIT THE MAINS VOLTAGE SUPPLY.
 FIT THE CORRECT OVERLOAD UNIT TO THE STARTER TO SUIT THE FULL LOAD MOTOR CURRENT RELATED TO THE MAINS VOLTAGE SUPPLY.
 ALL THE ABOVE IS CARRIED OUT IN THE MAIN CONTROL PANEL.

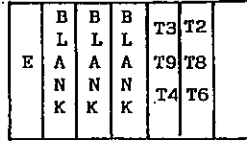

T1 to T9 CONNECTED FOR 220 VOLTS

LAYOUT DRAWING

LUBRICANTS

Application	A P P R O V E D L U B R I C A N T S						K.K. CROSSCUT
	I.S.O. No.	SHELL	B.P.	ESSO	CASTEROL	DOMINION	
General Lubrication	General Purpose Oil I.S.O. - 100	Vitreia 100	B.P. Energol EM 100	Nurray 100	Magna 100		
	Lithium LT 2	Alvania RA2	Energrease LT 2	Beacon 2	Spheerol AP 2	Hellenic LT 2	
Ball Bearing							
Pneumatic Cylinders + Valves	I.S.O. 37 Hydraulic Oil	Tellus 37	BP Hydraulic Oil 37	Nuto 37	Hyspin AWS 37		

TECHNICAL INFORMATION

Capacity	300 mm x 100 mm
Motor	5.5kw. (7.5 h.p.) Alt. 7.5kw. (10 h.p.)
Spindle Speed	2200 r.p.m.
Saw diameter	508 mm (20") 30 mm bore
Air requirements	6 bar, 80 p.s.i. (0.16 c.f. per cycle)
Dust extraction requirements	11m ³ /min.
Electric supply	380-420 V 3ph. 50 cycles 110 V controls
Saw bore and Pin Hole size and centres	Bore 30 mm Pin Hole 14mm Centres 30 mm
Dust extraction outlet	175 mm x 90 mm

A good quality T.C.T. Saw tensioned for 2200r.p.m. is recommended - Type 10BA19

NOISE

In the correct environment and using a good quality T.C.T. Saw e.g. Gomex 10BA19 a decibel reading of 85 dB(A) is the norm.

PNEUMATIC DIAGRAM

An air filter and lubricator is recommended to ensure clean dry air is fed to the machines pneumatic system.

GENERAL

Clean, maintain and protect all working parts regularly to prolong machine life and efficiency.