

**MICROPROCESSOR CONTROLLED**

**CROSSCUT SAW**

**MPS 14/0**

**INSTRUCTION MANUAL No.1432**

MICROPROCESSOR CONTROLLED CROSS-CUT SAW

MODEL "MPS" 14/0

INSTRUCTION MANUAL NO: 1432

ALWAYS QUOTE MODEL AND MACHINE NO.; SECTION NO.; WHEN ORDERING SPARES  
SPARE PARTS

SHOULD SPARE PARTS BE REQUIRED DUE TO BREAKAGE OR WEAR, FULL PARTICULARS INCLUDING MACHINE AND TEST NUMBER MUST BE GIVEN, THIS INFORMATION IS ON THE NAMEPLATE ATTACHED TO THE BODY ON THE OUTFEED SIDE OF THE MACHINE AND SHOULD BE FORWARDED TO THE ENGINEERING SERVICE DEPT.,

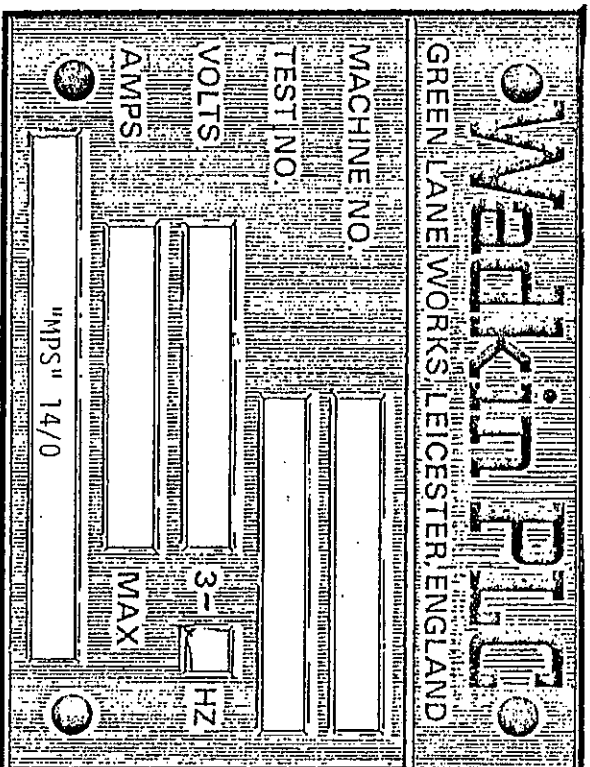

SAMPLE TYPE ORDER

MACHINE

"MPS" 14/0

MACHINE NO:

TEST NO:

PARTS REQUIRED

- 2 - SPA 1700 SAW ARM DRIVE BELT
- 2 - 6015 2RS PIVOT BEARING TO SAW ARMS

In the event of any query regarding the operation of the MPS/14/0/PL please contact the ENGINEERING SERVICE DEPT., of WADKIN.

Orders for spare parts should be sent only to the following address:-

Wadkin p.l.c.  
Engineering Division  
Green Lane Road  
Leicester ..... LE5 4PF  
England.

TELEPHONE: LEICESTER (0533) 769111 Outside the U.K.  
+ 44 533 769111

TELEX: 34646

ATTENTION

THIS MACHINE CAN BE DANGEROUS IF IMPROPERLY USED.

ALWAYS USE GUARDS

KEEP CLEAR UNTIL ROTATION HAS CEASED

ALWAYS OPERATE AS INSTRUCTION AND IN ACCORDANCE WITH GOOD PRACTICE.

READ THE INSTRUCTION MANUAL.

NOTE:

THIS MACHINE, WHEN UNDER WORKING CONDITIONS, MAY PRODUCE A NOISE LEVEL IN EXCESS OF 90 DB. "WADKIN" PLC, WILL SUPPLY INFORMATION ON ACOUSTICAL ENCLOSURES (ALREADY FITTED) ON REQUEST, AND WILL REQUIRE A WRITTEN UNDERTAKING THAT THE NECESSARY STEPS WILL BE TAKEN TO ENSURE THAT THE MACHINE IS ONLY USED IN COMPLIANCE WITH THE TERMS OF HEALTH AND SAFETY AT WORK - ACT 1974.

IT IS RECOMMENDED THAT ALL PERSONNEL INVOLVED WITH THE MACHINE ARE ACQUAINTED WITH THE WOODWORKING MACHINES REGULATIONS, 1974 AND ALSO BOOKLET No: 41 - SAFETY IN THE USE OF WOODWORKING MACHINES - THE LATTER IS ISSUED BY THE DEPARTMENT OF EMPLOYMENT AND AVAILABLE FROM HER MAJESTY'S STATIONERY OFFICE.

IMPORTANT

IT IS OUR POLICY AND THAT OF OUR SUPPLIERS TO REVIEW CONSTANTLY THE DESIGN AND CAPACITY OF OUR PRODUCTS. WITH THIS IN MIND WE WOULD REMIND OUR CUSTOMERS THAT WHILST THE DIMENSIONS AND PERFORMANCE DATA CONTAINED HEREIN ARE CURRENT AT THE TIME OF GOING TO PRESS, IT IS POSSIBLE THAT, DUE TO THE INCORPORATION OF LATEST DEVELOPMENTS TO ENHANCE PERFORMANCE, DIMENSIONS AND SUPPLIES MAY VARY FROM THOSE ILLUSTRATED.

## SAFETY RULES

THE SAFE OPERATION OF WOODWORKING MACHINERY REQUIRES CONSTANT ALERTNESS AND CLOSE ATTENTION TO THE WORK IN HAND.

CAREFULLY READ INSTRUCTION MANUAL BEFORE OPERATING MACHINE.

DO NOT OPERATE WITHOUT ALL GUARDS AND COVERS IN POSITION.

BE SURE MACHINE IS ELECTRICALLY EARTHED - GROUNDED.

REMOVE OR FASTEN LOOSE ARTICLES OF CLOTHING - SUCH AS NECK-TIES ETC, CONFINE LONG HAIR,

REMOVE JEWELLERY - SUCH AS FINGER RINGS, WATCHES, BRACELETS ETC.

USE SAFETY FACE SHIELD, GOGGLES OR GLASSES TO PROTECT EYES AND OTHER PERSONAL SAFETY EQUIPMENT AS REQUIRED.

"STOP" MACHINE BEFORE MAKING ADJUSTMENTS OR CLEANING CHIPS FROM WORK AREA.

BLUNT SAWS OFTEN CONTRIBUTE TO ACCIDENTS. AN EFFICIENT MACHINIST KNOWS WHEN RE-SHARPENING IS NECESSARY, BUT IF THERE IS RELUCTANCE TO SPEND TIME ON GRINDING AND RE-SETTING, THE SAWS MAYBE RUN BEYOND THEIR EFFICIENT LIMITS AND INSTEAD OF CUTTING EFFICIENTLY AND SMOOTHLY, THEY TEND TO CHOP AND SNATCH AT THE WOOD. THIS NOT ONLY INCREASES THE RISK OF ACCIDENTS BUT ALSO LOWERS THE QUALITY OF WORK

KEEP THE FLOOR AROUND THE MACHINE CLEAN AND FREE FROM SCRAPS, SAWDUST, OIL OR GREASE TO MINIMISE THE DANGER OF SLIPPING.

## INDEX

Introduction / MPS 14/0 / MPS 14/PL	page 1
Installation / Cleaning / Levelling / The foundations	page 2
The Electrical Supply / Pneumatic branch circuits	page 3
Pneumatic circuit diagram	page 4
Lubricator / Operation and Service	page 4a
Filter / Regulator / Operation and Service	page 4b
The "MPS" 14. Micro-processor controlled cross-cut saw	page 5
Adjustments / To change the saws	page 6
Routine maintenance	page 7
Adjustment of toothed belts - measuring roll drive	page 8-a
List of wearable parts	page 9

SECTION	ELECTRONIC SECTIONS	
1	General Information	page A
2	The control panel	page B - E
3	Option selection (cutting list entry etc.,)	page F - L
4	Operating the machine	page M - N
5	Error messages during operation	page O - P
6	Ancillary equipment (as applicable)	page Q - S

## INTRODUCTION

The "WADKIN" MPS 14/0 Machine is designed to:-

- a) Accept a cutting list requirement.
- b) Measure random length timber put into it.
- c) Optimise the best cutting pattern available.
- d) Cut the calculated lengths.
- e) Provide an account of its progress through the cutting lists.

The "WADKIN" MPS 14/PL Machine is designed to:-

- a) Accept packaged to length timber, so the cutting list must be arranged to accommodate lengths in accordance with the input timber length.
- b) Cut the lengths in the order entered in the cutting list but will remain with the first length until the quantity requirement is met. The sequence returns to the top of the list with each new board so there is no 'end of run' report.

This handbook does not attempt to describe the function of the machine, this is set out in the service handbook, but will enable the machine to be operated and basic maintenance to be carried out. The information contained must be used in conjunction with the training given on the MPS 14/0 by WADKIN Engineers.

## INSTALLATION

Loading and unloading - take careful note of the weight.

Having verified the weight. The machine must be lifted by a suitable fork lift truck only - using the slots provided in the base. (3 optional positions).

### MOVING INSTRUCTIONS

In the process of moving the machine avoid jolting OR vibrating it. The machine can be located on wooden plinths if the ground is flat and moved by rollers instead of lifting.

### METHOD OF UNPACKING, CLEANING, ASSEMBLING AND RE-SITTING.

Undo the packing and make sure that damage has not occurred during transit and ascertain that the machine is complete.

### CLEANING

Before levelling the machine, carefully remove the anti-rust material particularly from the bright parts.

Clean with petrol and soft rag.

DO NOT USE A SUBSTITUTE - IT MAY PRECIPITATE AN EXPLOSION.

Smear a tight coat of grease on the bright parts.

### LOCATION OF THE MACHINE.

To obtain the best results from the machine it is important that the floor on which the machine is to stand has been prepared and is dry.

Place under the adjustable screws the steel plates supplied with the machine.

### SUGGESTED LEVELLING AIDS.

A straight edge 1 metre long.

An Engineer's spirit level.

### LEVELLING.

Rest the straight edge on the measuring rolls, place the level on the straight edge. Set the machine level by utilising the adjusting screws in the feet of the machine.

### THE FOUNDATIONS.

If the floor consists of 100mm. - 150mm. (4 to 6 inches) solid concrete, no special foundation is necessary. M16. "HILTI" type holding down bolts may be used (these are not supplied with the machine). For both the machine and the Infeed conveyor. Align fence on Infeed table with fence at Infeed side of machine and set the last measuring cell on the conveyor 930mm. from the saw line cell (this dimension is critical to the accurate function of the machine).

NOTE: THE MACHINE AND CONVEYOR MUST BE BOLTED DOWN

October, 1984

## THE ELECTRICAL SUPPLY

The Customer is responsible for an adequate electrical supply.

The machine is delivered with its complete electrical equipment. The electrical wiring diagram and the pneumatic diagram are found in the electrical control cubicle of the machine.

All that is required is to connect the power supply to the Isolator switch at the electrical control cubicle.

### POINTS TO NOTE WHEN CONNECTING THE POWER SUPPLY.

- 1) Check the voltage, phase and frequency with those on the machine nameplate.
- 2) Check that the main fuses are of the correct capacity in accordance with the machine nameplate.
- 3) Connect the incoming supply leads to the appropriate terminals.
- 4) Check that all connections are sound.
- 5) Right Hand feeding machines - anti-clockwise.  
Left Hand feeding machines - clockwise.
- 6) Clockwise when viewed from Outfeed end of machine

**IMPORTANT: ANY MODIFICATIONS SHOULD BE CARRIED OUT BY AN ELECTRICIAN.**

### PNEUMATIC BRANCH CIRCUITS.

Size of Air Inlet connection is 3/8in. B.S.P. FEMALE.

Pressure = 6 bar (atm)

The air consumption is approximately 11 Cu.feet / min.

### THE EXHAUST (DUST EXTRACTION) CONNECTIONS (RECTANGULAR OUTLETS)

Adaptor pieces 170mm. x 50mm. inside dimensions (not supplied).

The total volume of air required for the Dust Extraction is 22<sup>3</sup>M/min. (1000 CFM).



## LUBRICATOR

### OPERATION AND SERVICE

- 1) FILLING - Disassembly of the oil fill plug removes and vents the bowl pressure and allows filling without shutting down the air supply line. Fill to visible rim of the bowl with oil of 4.5<sup>0</sup> - 5.50E at 50°C viscosity - same as SAE No.10 (petroleum base hydraulic oils or spindle oils are good examples).

NOTE: DO NOT USE OILS WITH ADHESIVES OR TACKY ADDITIVES. COMPOUNDED OILS CONTAINING SOLVENTS, GRAPHITE, SOAPS, OR DETERGENTS (AUTOMOTIVE OILS GENERALLY CONTAIN DETERGENTS) ARE NOT RECOMMENDED.

- 2) Replace the fill plug and seat firmly. Excessive torque is not necessary. The lubricator is now ready for setting.
- 3) OIL DELIVERY ADJUSTMENT - To adjust oil delivery, use a slotted screw-driver to turn the adjusting screw in the top of the lubricator.

LEANER - Clockwise  
RICHER - Counter-clockwise

By counting the number of drops per minute in the sight dome, you can adjust to your requirements. Generally, one drop per minute for every 300-400 L/min. flow is satisfactory.

25 drops per minute equals 30 g/hr.

The recommended rate for the MPS 14 is one drop per minute for air motor circuit and 2 drops per minute for cylinder circuit.

NOTE: This is a constant density type lubricator which delivery a constant ratio of oil to air flow. Therefore, if air flow increases or decreases, oil delivery will be adjusted proportionately. ONLY IF A DIFFERENT RATIO IS DESIRED NEED YOUR NEEDLE VALVE SETTING BE CHANGED AFTER YOUR INITIAL SETTING.

### CAUTION

Polycarbonate bowls being transparent and tough, are ideal for use with Filters and Lubricators. They are suitable for use in normal industrial environments, but should not be located in areas where they could be subjected to an impact blow, nor temperatures outside of the rated range. As with most plastics some chemicals can cause damage Polycarbonate bowls should not be exposed to chlorinated hydro-carbons, ketones, esters, and certain alcohols. TO CLEAN POLYCARBONATE BOWLS USE MILD SOAP AND WATER ONLY! DO NOT use cleaning agents such as acetone, benzene, carbon tetrachloride, gasoline toluene etc., which are damaging to this plastic.

They should not be used in air systems where compressors are lubricated with fire resistant fluids such as phosphate esters and di-ester types in areas where polycarbonate bowls are exposed to high temperature or atmospheres containing vapors or fluids which are damaging to plastic, use metal bowls.

Metal bowls resist the action of most such solvents, but should not be used where strong acids or bases are present or in salt laden atmospheres. Consult the factory for specific recommendations where these conditions exist.

Bowl guards are recommended for use with polycarbonate bowls.

## FILTER / REGULATOR

### OPERATION AND SERVICE

- 1) Both free moisture and solids are removed automatically by the FILTER / REGULATOR.
- 2) An automatic drain is fitted to the Filter / Regulator.
- 3) The filter element can be removed when necessary and should be washed in the same solution as the transparent bowl. .... See SAFETY: TRANSPARENT BOWLS Section. Blow compressed air from inside the element outward after washing. When dry, re-install, making sure to replace all gaskets, each in its proper place.
- 4) To remove the filter element: SHUT AIR LINE DOWN and exhaust secondary pressure.
  - (a) Unscrew threaded bowl.
  - (b) Disassemble cartridge assembly by unscrewing lower baffle.
  - (c) Remove element for servicing.
  - (d) Replace element and reassemble.
- 5) BEFORE TURNING ON AIR SUPPLY, TURN ADJUSTING HANDLE COUNTER-CLOCKWISE UNTIL COMPRESSION IS RELEASED FROM PRESSURE CONTROL SPRING. Adjustment to desired downstream pressure can be made only with primary pressure applied to the Regulator. Regulator then acts as shut-off valve. Turn on air pressure. Then proceed to adjust to desired downstream pressure by turning adjusting handle clockwise. This permits pressure to build up slowly preventing any unexpected operation of valve, cylinders, tools, etc., in the line.
- 6) To increase regulated pressure, turn adjusting handle clockwise. Adjustment can be made either with or without air flowing. It is desirable to make the adjustment to required pressure under typical operating conditions. When desired setting has been reached, tighten locknut securely.
- 7) Your FILTER / REGULATOR is self-relieving unless specifically ordered otherwise. Therefore it is not necessary to "blow-down" the secondary lines by exhausting them. To lower setting, always reset from a pressure lower than the final setting desired. For example; lowering the secondary pressure from 6 bar to 4 bar is best accomplished by dropping the secondary; pressure to 3 bar or less, then adjusting UPWARD to 4 bar.
- 8) Before disassembling FILTER / REGULATOR, SHUT OFF AIR SUPPLY. The Regulator may be serviced without removing it from the line. Turn the adjusting handle counter-clockwise to bleed down trapped pressure. For servicing piston or control springs unscrew bonnet from body. For servicing the poppet and relief tube remove threaded bowl and filter element cartridge assembly.
- 9) Clean and carefully inspect parts for wear or damage. If replacement is desired, service kits are available. .... See SERVICE KIT Section. When reassembling Filter / Regulator, be sure to replace parts in their correct order. If unit does not function properly, recheck the assembly using the parts exploded view information as a guide.

THE "MPS" 14. IS A MICRO-PROCESSOR CONTROLLED CROSS-CUT SAW.

The timber cut lengths are measured by the rotation of the large diameter measuring and driving rolls.

The various sensors on the machine and infeed table pass information to the micro-processor.

The variable speed drive is from a D.C. Motor, through a "Toothed" belt drive system.

The rotation of the measuring rolls is measured by a shaft encoder fitted to the shaft of one of the measuring rolls.

An Electro-magnet brake is provided on the shaft of the other measuring roll to hold the rolls stationary whilst the timber is being cut.

A pneumatic motor powers the roller at the infeed side of the machine.

All the bearings are 'Sealed for life' and should need no extra lubrication.

Two pneumatic filter / lubrication units are provided. One unit to service the pneumatic motor and the other unit to service all other pneumatics on the machine.

Ensure that the lubrication bottles have an adequate supply of oil at all times and the filters are drained at frequent intervals.

A "FAIL SAFE" switch is provided so that should the air supply fail, the machine will be electrically isolated automatically.

The front and rear doors are each provided with an air-operated locking bolt and also an "ISO-MAG" switch, so that, when either of the doors are opened the machine is isolated electrically.

## ADJUSTMENTS

Set Air Pressure to 5.5 BAR (80 P.S.I.).

TO ADJUST THE INITIAL HEIGHT OF THE SAWS. OPEN REAR DOOR.

Slacken each "KIPP" handle situated at the rear of the cylinder support bracket, then operate the ratchet handle to raise OR lower the cylinders on the saw arms. Re-lock "KIPP" handle when completed.

NOTE: THE CYLINDERS MUST BE PRESSURISED TO THE UP POSITION WHEN THIS OPERATION IS CARRIED OUT.

The maximum setting height of the centre line of the saw spindles is 440mm. and the minimum setting height 300mm. above the measuring rolls.

TO ADJUST THE HEIGHT OF THE INFEED ROLLER AND CLAMP.

First slacken the "KIPP" handle on the support bracket, then turn the handwheel at the top of the bracket to give the required height.

Re-lock "KIPP" handle when completed.

NOTE: THIS OPERATION MUST BE CARRIED OUT WHILST THE NIP-ROLL CYLINDER IS PRESSURISED IN THE UPWARD POSITION.

The top pressure rolls above the measuring rolls do not require setting.

The adjustable flow control valves for the air cylinders are situated at the rear of the valve block and are integral with the silencers. These control the speed at which the air cylinders operate. ... see Pneumatic Diagram

page 4.

TO CHANGE THE SAWS.

Open the front door. Switch off the electricity. Slacken two nuts securing hardwood outfeed saw anvil. Lift saw anvil clear of machine.

Place saw changing stand on machine body - (up to fence and central to saw arms).

Switch off the air. The arms will now descend to rest on saw changing stand.

Remove saw locknuts.

NOTE: THE LEFT HAND SAW LOCKNUTS HAVE RIGHT HAND THREADS AND THE RIGHT HAND SAW LOCKNUTS HAVE LEFT HAND THREADS.

Change the saws - ensure locknuts are tight.

Switch on the air - the saw arms will now rise to their original position.

Remove the saw changing stand.

Replace the saw anvil - tighten nuts.

Switch on the electricity.

October, 1984

## ROUTINE MAINTENANCE

Periodically clear the sawdust and waste from in and around the machine.

Check the oil in the lubrication bottles.

Check the tension of the toothed and vee belts at approximately three monthly intervals - otherwise and the drive is maintenance free.

Ensure measuring rollers are clean from resin build up.

Clean fan filters on electrical cabinet.

The drive belts on the saw spindles are tensioned by a "jockey" pulley situated on each saw arm.

The belts from the motor to the driving spindles are tensioned by elevating the motor.

Should it be necessary to change the belts from the motor - proceed as follows:-

- 1) Stacken the belts.
- 2) Unscrew the four grub screws in the flexible coupling and slide the coupling along to the right.  
A gap in the shaft is now exposed so that the belts can be changed.
- 3) When the new belts are in place ensure that the key in the left hand shaft lines up with the keyway in the coupling, then slide the coupling into position.
- 4) Re-lock four grub screws, and then re-tension the belts by elevating the motor.

MEASURING ROLLS

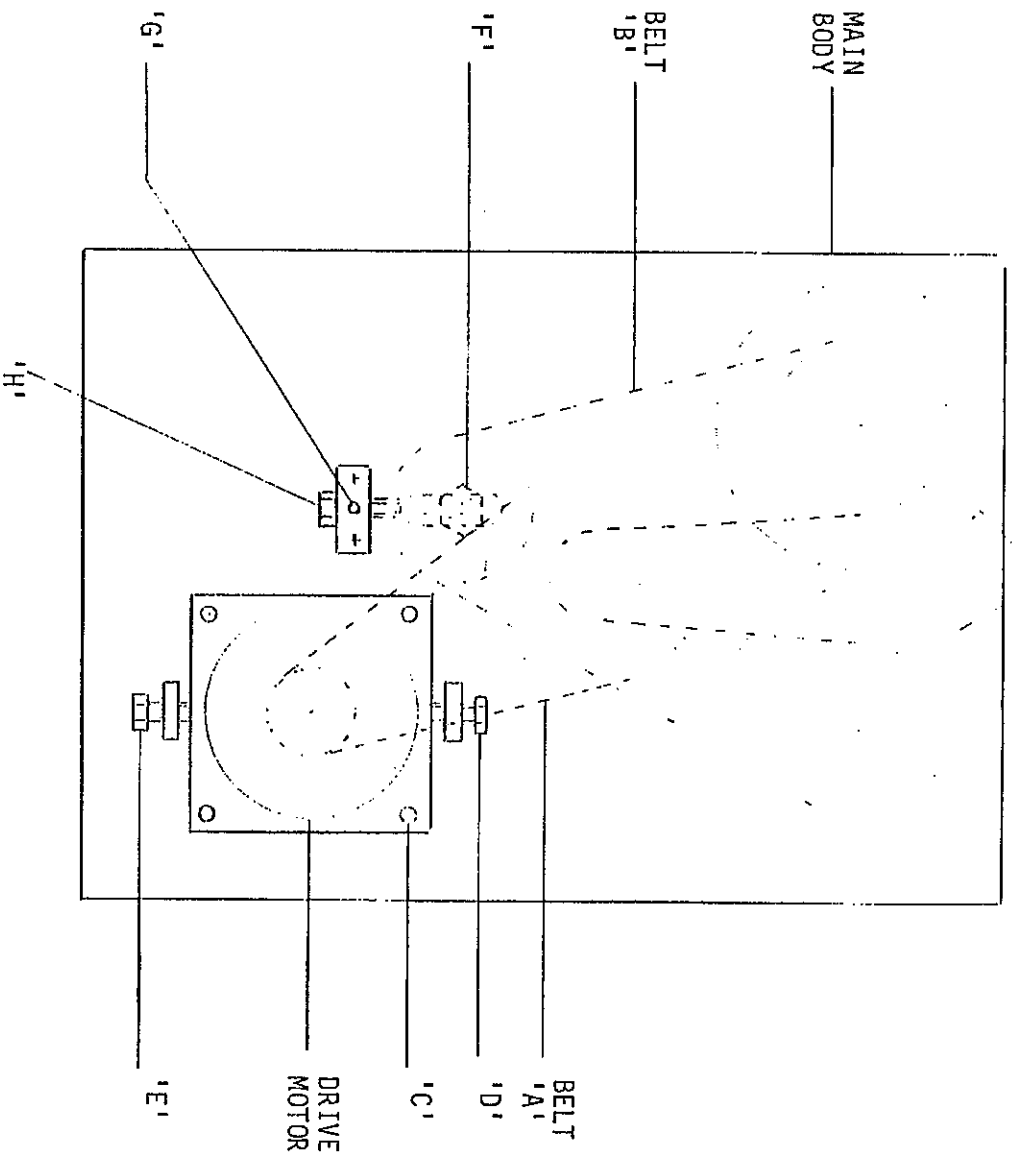

VIEW FROM REAR OF MACHINE

ADJUSTMENT OF TOOTHED BELTS - MEASURING ROLL DRIVE.

Remove sheet steel cover from rear of machine.

TO ADJUST: BELT 'A' - Slacken 4 screws 'C' on motor.

Adjust tension by means of screws 'D' and 'E'.  
Tighten screws 'C'.

TO ADJUST: BELT 'B' - Slacken nut 'F' (inside body at front of machine).

Slacken grub screw 'G' (at rear of machine).  
Adjust tension by means of screw 'H' (at rear of machine).

Tighten screws 'F' and 'G'.

### TOOTHED BELT DRIVE

Since this type of drive is essentially a gear type drive, it is necessary to only tension the belts to prevent the teeth riding out of the pulleys.

Damage can be caused by over-tensioning the belts.

The recommended tension is shown on diagram below:

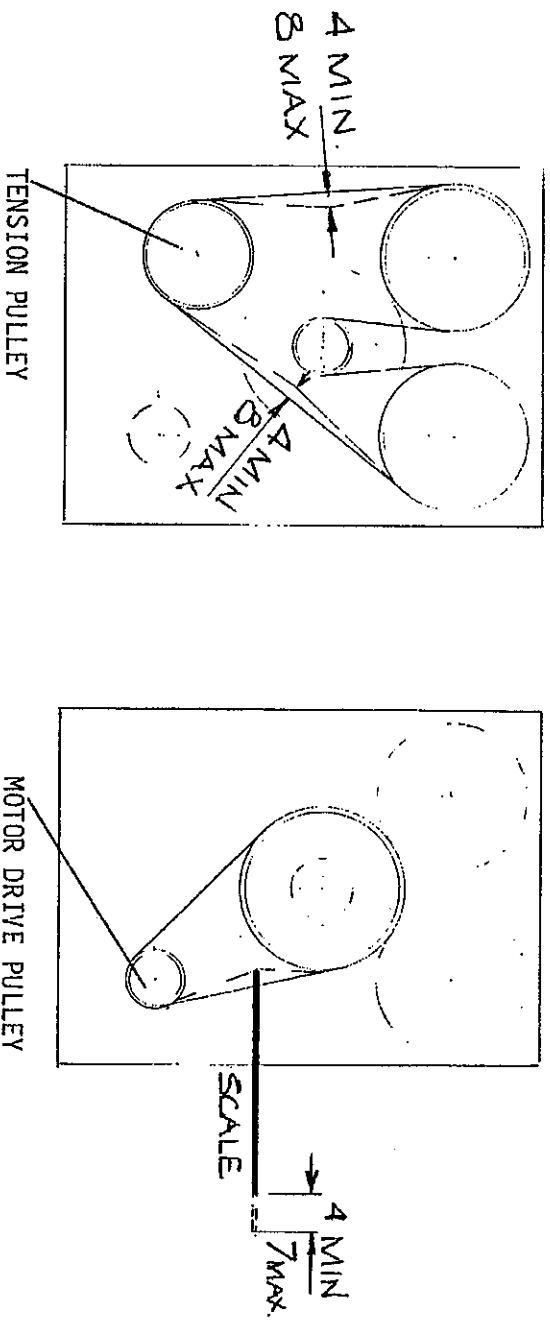

Further, to maintain the efficiency of this type of drive, it is essential that the belts are kept clean and free from sawdust etc.,

To achieve this, it is strongly recommended that any accumulation of sawdust on the base of the machine should be cleared either by extraction (i.e. suction type device) OR by brush.

The use of an airline to clear the sawdust tends to blow it onto the belts and pulleys which when the machine is operated will then clog the toothed pulleys. This could result in breaking the belts, due to the abnormal increase in their tension.

LIST OF WEARABLE PARTS

REF. NO.:	DESCRIPTION	NO:OFF
SPA 1700	Saw arm drive belts (2 per saw arm)	4
SPA 800	Motor drive belts to saw spindle <del>130</del> 78 444	2
6015 2RS	Pivot bearing to saw arms (2 per pivot)	4
6208 2Z	Saw spindle bearings (2 per spindle)	4
6206 2RS	Jockey pulley bearing (1 per pulley)	2
6206 2RS	Motor driven spindle to saw arm bearings	4
6308 2RS	Measuring roll spindle bearings	4
6306 2RS	Driving spindle bearings	2
6206 2RS	Tension pulley bearing	2
6205 2RS	Brake bearing	1
6206 2RS	Top pressure roll bearings (2 per roll)	4
RHP SL25	Pillow block bearings to infeed rolls	2
D 132	Saw drive motor - 2880 RPM. 440 VOLTS. 10 HP. 50 HZ. 3 PHASE.	
TOOTHED DRIVING BELTS		
T10 / 780	"SYNCHROFLEX" belt 78 teeth 50mm. wide	1
T10 / 1610DL	"SYNCHROFLEX" belt 161 teeth 75mm. wide (Double toothed)	1
Electro-magnetic brake		
"SIMPLATROLL" NO: 14.115.10.1.1.050.446		1
24 VOLTS D.C.SIZE 10 Ø 25 BORE		
K12 08 455	Wadkin Ref.No.	

## SECTION ONE

## GENERAL INFORMATION MPS 14/0

TIMBER WIDTH	-	MAXIMUM	250mm.
	-	MINIMUM	40mm.
TIMBER THICKNESS	-	MAXIMUM	150mm.
	-	MINIMUM	12mm.
CROSS SECTION (typical)	-	MAXIMUM	250mm. x 50mm. 150mm. x 100mm.
	-	MINIMUM	40mm. x 20mm. 75mm. x 15mm.
INPUT LENGTH	-	MAXIMUM	6300mm.
	-	MINIMUM	1000mm.
CUT LENGTH	-	MAXIMUM	5000mm.
	-	MINIMUM	50mm. (Except last piece)
MACHINE FEED SPEED	-		120m/min.
NUMBER OF CUTTING LISTS	-		5
NUMBER OF LENGTHS PER LIST	-		20
QUANTITY PER LENGTH	-	MAXIMUM	9999
SAW DIAMETER	-		550mm.
SAW SPINDLE SPEED	-		2740rpm.
AVERAGE SAW CYCLE TIME (Adjustable)	-		0.5seconds
SAW MOTOR	-		7.5k.w.
SUPPLY VOLTAGE STANDARD	-		415volts 50hz. 3phase
OPERATING LOAD	-		10k.w.
COMPRESSED AIR REQUIREMENT	-	AT	5.5-6 BAR 340 litres/min.(12 cu/ft.
DUST EXTRACTION REQUIREMENTS	-		M <sup>3</sup> /min. 22 /min)
STANDARD BED HEIGHT	-		870mm.

N.B.

The information given above applies to a standard machine. Some differences may be found where a machine has been built to meet certain Customer requirements, this applies also to the detailed text of this handbook.

2. THE CONTROL PANEL

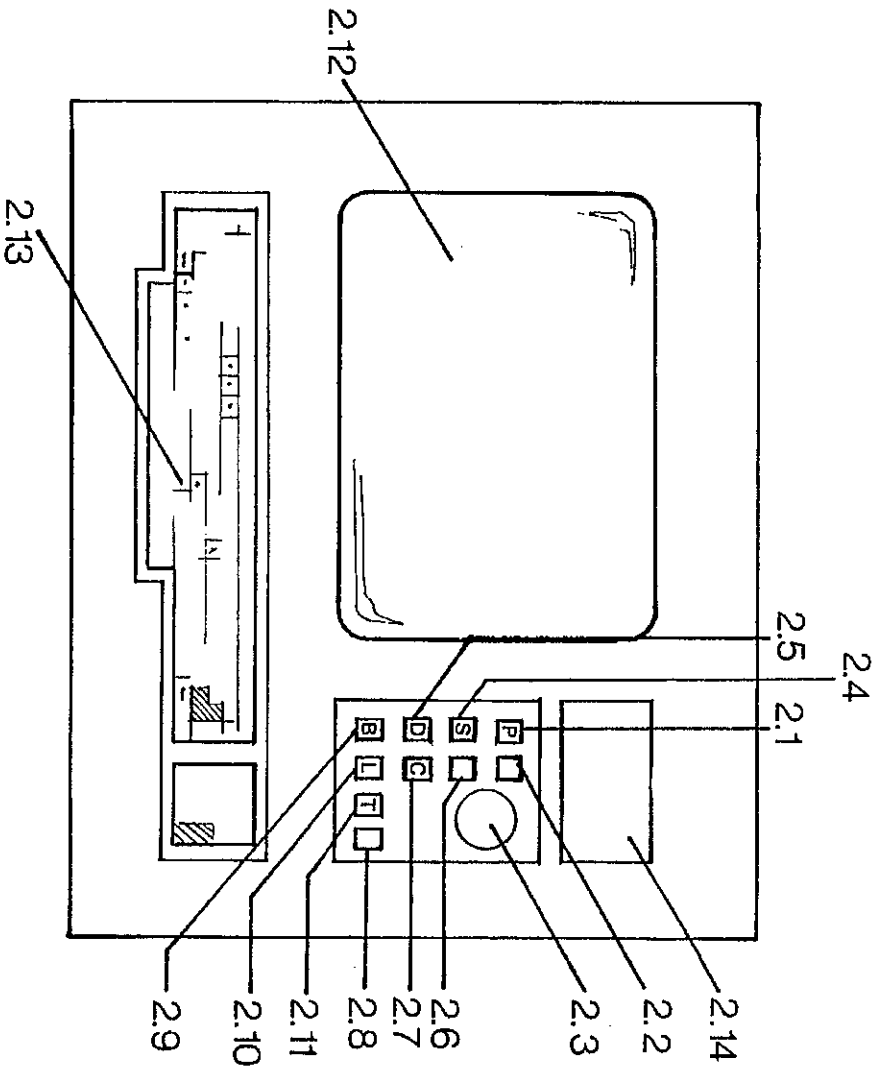

- 2.1 POWER ON BUTTON
- 2.2 POWER OFF
- 2.3 MASTER "STOP"
- 2.4 SAWS "ON"
- 2.5 DATUM
- 2.6 SAWS "OFF"
- 2.7 CYCLE BREAK
- 2.8 ATTENTION REQUIRED LAMP (ALSO OPTIONAL SWITCH FUNCTION)  
"OPTIONAL"
- 2.9 BOWED BOARD
- 2.10 NON-STANDARD LEADING TRIM
- 2.11 NON-STANDARD TRAILING TRIM
- 2.12 VISUAL DISPLAY UNIT. (VDU)
- 2.13 KEYBOARD
- 2.14 CASSETTE READER (IF FITTED)

- 2.1 POWER ON
- This button when pressed applies power to the control systems of the machine. The master "STOP" buttons must be released, the saw guards closed, the main electrical isolator switched on and the air supply connected. When on, the button will be illuminated.
- 2.2 POWER OFF
- This non latching button when pressed removes power to the machine.
- 2.3 MASTER "STOP"
- The master "STOP" button removes power to the machine and will latch in the off condition. The button is released by rotation.
- 2.4 SAWS START
- This button applies power to the saw motor.
- 2.5 DATUM
- The datum button initiates the machine operating cycle.
- 2.6 SAWS OFF
- Removes the power to the saw motor.
- 2.7 CYCLE BREAK
- This button can be pressed at any time during the machine cycle and enables certain options to be selected when the machine has finished processing the current input length of timber - when this occurs the button will be illuminated. To continue the machine operation, the datum button must be pressed.
- 2.8 ATTENTION REQUIRED LAMP
- This lamp will flash if the machine requires intervention by the operator. (On some machines fitted with ancillary equipment this lamp will also function as a pushbutton ..... see SECTION 6.0)
- 2.9 BOWED BOARD SELECTION "OPTIONAL"
- If the input length of timber is stressed such that it would produce an unacceptable bow in long cut components, the machine optimisation can be overridden and the length cut into multiples of a pre-determined shorter length ..... see Cutting list entry - SECTION 3.1.9).
- 2.10 NON-STANDARD LEADING TRIM SELECTION
- 2.11 NON-STANDARD TRAILING TRIM SELECTION
- Both these pushbuttons can be used to select a pre-determined leading and trailing trim cut if the standard trim setting is inadequate for the timber length being processed e.g. unsquare OR split ends. The size of the trim is set using Option 8 ..... see SECTION 3.8.

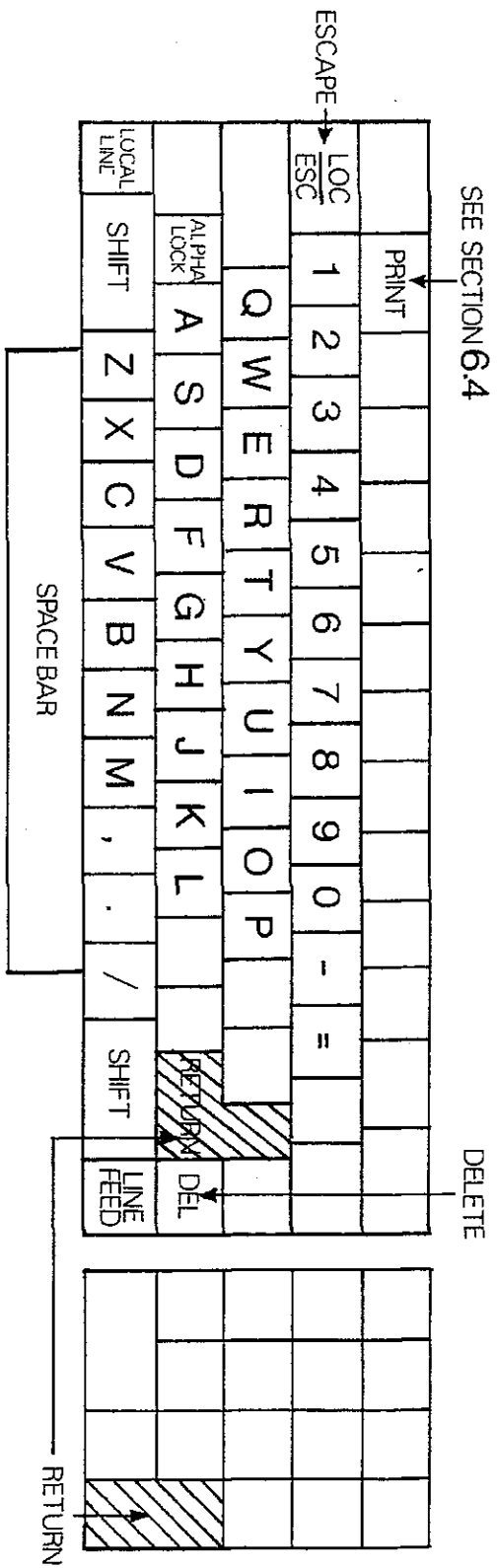

ONLY THE KEYS SHOWN ABOVE ARE APPROPRIATE TO THE MACHINE OPERATION

(Punctuation marks can be used when entering the Job. No. .... see SECTION 3.1.3)

2.11 NON-STANDARD TRAILING TRIM SELECTION ..... CONTD

The buttons once pressed, will remain illuminated until the next length of timber is fed into the saw unit, at which time the selection is cancelled until requested again. This sequence also applies to the Bowed board selection - SECTION 2.9

2.12 VISUAL DISPLAY UNIT

This unit will display all information entered on the Keyboard and that requested from the microprocessors memory, e.g. progress reports etc.

2.13 KEYBOARD

The keyboard is used to communicate all information required by the system ..... see keyboard layout drawing.

2.14 TAPE CASSETTE POSITION - IF FITTED

..... see SECTION 6.5

### SECTION THREE

#### OPTION SELECTION

- OPTION 3.1 - ENTER CUTTING LIST
- 2 - PARAMETER CHANGE
  - 3 - END OF RUN REPORT
  - 4 - QUANTITY CUT REPORT
  - 5 - TIMBER USAGE REPORT
  - 6 - COMPLETE REPORT
  - 7 - LIST SELECT
  - 8 - TRIM AND KERF SELECT
  - 9 - BIAS SELECT
- \* A - D/A TEST
- \* B - BIT TEST
- \* C - CELL TEST
- \* D - DRIVE TEST
- H - DISPLAYS THIS LIST OF OPTIONS
- I - IDENTIFY CURRENT OPERATING MODE
- L - CHANGE TO MPS14/PL
- \* M - MONITOR
- 0 - CHANGE TO MPS14/0
- \* T - TASK STATUS
- \* V - ENTER / ALTER VARIABLES

\* THESE OPTIONS ARE DETAILED IN THE MPS14 SERVICE HANDBOOK.

Options can only be selected when "ENTER OPTION" is displayed on the VDU. Option 4, 5, 6, 7, 8 and 9 can be selected when the machine is in operation by first pressing the CYCLE BREAK pushbutton ..... see SECTION 2.7

## SECTION THREE

- 3.1 ENTERING A CUTTING LIST - OPTION.1
- 3.1.1 When the machine is first switched on at the isolator, the message MPS14/0 ENTER OPTION will appear on the VDU. Type in the figure 1.
- 3.1.2 "LIST No." will be displayed. Type in the figure 1. Press return. The standard machine will accept up to five lists but when first switched on it is usual to select list 1. The system automatically assumes list one at this stage unless another list is to be selected, using Option 7.
- 3.1.3 "JOB No." is displayed. On a standard machine a combination of twenty numbers, letters, punctuation marks and spaces maybe entered for reference purposes. For less than twenty press return.
- 3.1.4 "WIDTH". Enter the timber width in millimetres. Press return.
- 3.1.5 "THICKNESS". Enter the timber thickness in millimetres. Press return.
- 3.1.6 "LENGTH" "No.OFF"  
Enter the first length in millimetres, press return. Enter the quantity requirement, press return. The system will now ask for the second length and so on until the list is complete. A maximum of 20 lengths can be entered, but if less are required just press return when prompted for the next entry ..... see 3.1.9.
- N.B. Lengths must be entered in decreasing order, i.e. longest first. If a mistake is made when entering a length, a question mark will appear against the entry and the line can be re-written. Errors will occur if the length is too small (50mm. minimum) too large (5000mm. maximum) OR the entry is longer than the previous length in the list.
- 3.1.7 The VDU will now display "MIN.RECYCLE 300". This is the shortest length that can be handled by other equipment, such as a finger jointer, and will occur if timber remains of the input length that is less than the shortest length in the list. Any timber remaining less than the minimum recycle figures will appear as waste.  
Enter up to four digits for this length. Minimum length is 50mm.  
..... see 3.1.9. Press return.

SECTION THREE

3.1.8 "B.B. CUT LENGTH 300". (B.B. = Bowed Board). If the input timber length is bowed to the extent that long components cut from it would be unusable, a preset length can be entered to produce shorter components of one length from the whole of the board. This figure is usually made equal to the shortest length in the list, and becomes operative when the Bowed Board pushbutton is pressed.  
..... see SECTION 2.9

Enter up to four digits for this length. Minimum length is 50mm.  
..... see 3.1.9. Press return.

3.1.9 The minimum recycle length and the Bowed Board length are preset each at 300mm. If these figures are acceptable, the escape key can be pressed when the component list is complete, otherwise they can be changed as described in ..... 3.1.7 and 3.1.8.

3.1.10 Typical cutting list entry format :  
"OPTIONAL"

```
LIST NO:      1      PRESS RETURN
JOB NO: ABC-1234      RETURN
WIDTH:       75      RETURN
THICKNESS:   50      RETURN
```

- LENGTH NO:OFF
1. 3500 RETURN 100 RETURN
  2. 2250 RETURN 250 RETURN
  3. 1500 RETURN 50 RETURN
  4. Either press RETURN or ESCAPE to finish list (RETURN will display :-

```
MINIMUM RECYCLE LENGTH 300 (Type in say) 500 OR RETURN
BOWED BOARD CUT LENGTH 300 (Type in say) 1500 OR RETURN
```

3.2 PARAMETER CHANGE - OPTION.2

Option 2 allows the Minimum Recycle length and the Bowed Board length to be changed without having to re-enter the whole cutting list. The procedure is as described in ..... SECTION 3.1.7 and 3.1.8.

To change parameters during machine operation, press the CYCLE BREAK pushbutton ..... see SECTION 2.7 and enter the required information when prompted by the appearance of "ENTER OPTION" on the VDU screen. However, the machine will have to be restarted from the DATUM condition as described in ..... SECTION 4.

SECTION THREE

3.3 END OF RUN REPORT - OPTION.3

Option 3 will terminate the current cutting sequence for the list in use and display a complete report of the state of the cutting list and timber used up to that point.

The cutting list can be retrieved, however, if the same list number is selected when a new list is to be entered using Option 1.

When the question "CUTTING LIST CHANGE REQUIRED. Y OR N" appears on the screen, if "Y" is entered the original list will be restored but the quantity requirement will revert to the initial entries.

3.4 QUANTITY CUT REPORT - OPTION.4

Option 4 will display the lengths and quantities cut at the time of taking a report.

This option can be selected during machine operation by using the "cycle break" button. The machine sequence can be restarted simply by pressing the "datum" button and continuing to feed timber.

3.5 TIMBER USAGE REPORT - OPTION.5

Option 5 produces a report of all timber input, output, waste etc. as follows. This option can be selected during the machine cycle as with Option 4.

	PIECES	METRES	%
3.5.1 INPUT	4	14.400	100

The incoming timber is measured as it feeds into the MPS14 and a record is kept of the number of lengths and the accumulative input meterage. In this example 4 lengths totalling 14.4 metres have been fed in and all subsequent calculations are expressed as a percentage of this.

3.5.2 OUTPUT	12	13.900	96.5
--------------	----	--------	------

The incoming timber has been cut into 12 lengths totalling 13.9 metres. This represents 96.5% of the input.

3.5.3 TRIM AND KERF	0.140		1.0
---------------------	-------	--	-----

A record is kept of the amount of leading and trailing trim and together with the kerf presented as a total meterage. In this example, 140mm. represents 1% of the input.

3.5.4 RECYCLE	0	0.000	00.0
---------------	---	-------	------

The number of lengths cut that exceed the Minimum Recycle Length but are less than the shortest length in the cutting list are recorded here together with total meterage. This timber can be put to further use.

SECTION THREE

	PIECES	METRES	%
3.5.5 WASTE		0.360	2.5

Any timber remaining that is less than the Minimum Recycle Length is considered to be waste. This example shows 360mm. of waste, 2.5% of the input meterage.

3.5.6 Ø BOWED BOARD(S) CUT INTO Ø PIECES.  
"OPTIONAL"

Each time the Bowed Board Select pushbutton is pressed, the system will record the number of boards and the total number of components cut.

3.6 COMPLETE REPORT - OPTION.6

Option 6 will display both the quantity cut report and the usage report. The display can be stopped by pressing the space bar should the report scroll off the screen. Pressing the space bar again will restart the display.

Again the option can be selected during the machine operation using the Cycle Break button.

3.7 LIST SELECT - OPTION.7

Option 7 is used to select the required cutting list. The system will automatically assume list 1 unless this option is used to select one of the remaining four.

The VDU display will be as follows :-

```
LISTS AVAILABLE - Will show the number of lists already entered.
LIST SELECTED  - Indicates the list currently in use.
LIST NO:       - Enter the required list number.
```

3.8 TRIM AND KERF SELECT - OPTION.8

Option 8 is used to set the amount of leading and trailing standard trim and the size of the non-standard trims. The saw kerf can also be changed. Preset values are contained in the machine program as follows :-

```
STANDARD TRIM      = 5
NON STANDARD L. TRIM = 100
NON STANDARD T. TRIM = 100
KERF                = 5
```

Each line above is displayed on the VDU in sequence. To change an entry, type in the new figure and press return. If the preset value is acceptable just press return.

Any amendment to these values will appear when Option 8 is selected again, but they will revert to the preset values if the machine is switched off at the isolator.

## SECTION THREE

### 3.9 BIAS SELECT - OPTION.9

Option 9 is used to adjust the optimisation program to suit a particular application. This can result in higher waste figures but can be used to advantage if the cutting list is rather unbalanced e.g. a large quantity of a particular length relative to the remainder. When this option is selected the VDU will display the following information :-

3.9.1 "PRIORITY" - This will indicate if a priority has already been selected i.e. Long length, Most Numerous OR Most Metrage.

3.9.2 "BIAS TO LENGTH NO. 0" - If a particular length in the cutting list is required in preference to other lengths, then a bias can be put on that length simply by typing in the number of the length as it appears in the list. The machine will cut as many of these lengths from the input timber as possible and also one OR two other shorter lengths to maintain the minimum possible waste figure. To cancel any existing entry, type ZERO followed by RETURN.

3.9.3 "LONG LENGTH? Y OR N." - The machine program is biased towards the longer lengths in the list. If a greater proportion of long lengths is required from the machine, then this bias should be selected.

3.9.4 "MOST NUMEROUS? Y OR N." - The same rule applies to the quantity requirement as with the long length in that the machine will cut more of the lengths with the greatest quantities attributed to them. Most Numerous bias will increase further the production of lengths in this category.

3.9.5 "MOST METRAGE? Y OR N." - This bias will put the machine into a condition that produces the highest possible throughput in terms of cut length metrage. The machine program will select appropriate lengths to achieve this but with a lower priority for the minimum possible waste figure.

Each priority will appear on the VDU in the above order. If no "Bias to length" is required, press return, "Long Length? Y or N" will appear on the screen. If N is entered, the next priority request will be displayed, and so on.

When a priority is selected the sequence is terminated. This status will be shown on the VDU every time the Datum button is pressed. Only one priority can be selected at any one time.

### 3.10 OPTION I - IDENTIFY MODE

This option is used to establish the mode of operation the machine is currently in.

The VDU will display either :-

MPS14/0 - Optimisation Mode OR

MPS14/PL - Package to length Mode

## SECTION THREE

### 3.11 OPTION L - PACKAGE TO LENGTH MODE

The MPS14, when first switched on, operates in the Optimisation mode. To change operation for packaged timber, type in the letter 'L'. Since changing modes of operation cancels all existing cutting lists, a safeguard is built in to check that the operators request is valid as follows :-

3.11.1 Type in 'L'

3.11.2 VDU displays "ARE YOU SURE? Y OR N"

3.11.3 Type in 'Y' to change mode OR 'N' to remain with the current mode.

3.12 OPTION 0 - OPTIMISATION MODE

Option 0 selects the optimisation mode of operation. The same rules apply to the erasure of cutting lists as with Option L.

## SECTION FOUR

### 4.0 OPERATING THE MACHINE

- 4.1 Switch the machine on at the isolator and press the master "STOP" button.
- 4.2 Establish the mode of operation and change using Option L if required.
- 4.3 Enter a cutting list as described in ..... SECTION 3.1
- 4.4 Set the required trims as detailed in .... SECTION 3.8
- 4.5 Set any bias required using Option 9.
- 4.6 Place a length of timber in the saw unit long enough to cover both drive rollers and to project (say) 50mm. past the infeed saw.
- 4.7 Adjust the nip roller assembly for the correct clearance with the timber in use. The top shoes of the infeed clamp should be approximately 10mm. - 15mm. above the timber. Lock the assembly when adjustment is complete. Set the clearance of the sawblades to be around 20mm. - 30mm. above the timber.
- 4.8 Close all machine guards and release the master "STOP" buttons.
- 4.9 If using a cutting list other than List 1, select that required using Option 7.
- 4.10 Press the power on button ..... see SECTION 2.1
- 4.11 Press the saws on button ..... see SECTION 2.4
- 4.12 Press the datum button ..... see SECTION 2.5
- The infeed saw will now cycle and cut the length of timber placed in the machine in ..... SECTION 4.6. This will establish a DATUM condition, and the infeed conveyor will start ..... see 4.15.
- The VDU will display the machine status at this point and if the preset parameters have not been changed, it will read as follows :-
- ```
MPS14/0
LIST SELECTED      = 1
STANDARD TRIM      = 5
NON STANDARD L. TRIM = 100
NON STANDARD T. TRIM = 100
PRIORITY           = NONE
BIAS TO LENGTH     = 0
```

- 4.13 Timber may now be fed into the saw unit and lengths will be cut in accordance with the cutting list. Do not place hands over the end of the timber as it moves down the conveyor as this can corrupt the length measurement procedure.

#### SECTION FOUR

- 4.14 When the cutting list is complete, the machine will stop feeding and the Attention Required lamp ..... see 2.8 with flash. An end of run report will automatically appear on the VDU. At this point a new list can be entered ..... see SECTION 3.1 OR the old list recovered ..... see SECTION 3.3.
- 4.15 AUTOMATIC DATUM: The machine Datum condition can be established without manually placing timber in the saw unit as described in ..... SECTION 4.6.
- 4.15.1 Prepare the machine for operation as in ..... 4.1 - 4.5, 4.7 - 4.9.
- 4.15.2 Press the power on, saw start and datum buttons in turn. The infeed conveyor will start.
- 4.15.3 Place a length of timber on the infeed conveyor in excess of 2 metres.
- 4.15.4 The timber will travel into the saw unit, and the feed rollers will position for a Datum cut, part way along the length. The remaining timber will be measured and treated as a new input length.
- 4.15.5 The machine can now be loaded with timber as described in ..... SECTION 4.13.
- 4.16 To stop the machine at any time, simply press a "STOP" button.
- 4.17 At the end of the working day, the machine can be switched off at the isolator. However, any information entered such as cutting lists, new parameters etc. will be lost.

## SECTION FIVE

### 5.0 ERROR MESSAGES DURING MACHINE OPERATION

During the machine operation, a number of specific conditions can arise that are recognised by the machine program and prompt messages to be displayed on the VDU.

#### 5.1 "SELECT LIST"

This message will appear if the datum button is pressed and the list that has been entered is not selected using Option 7. It will also appear if an attempt is made to run the machine without any list entered, OR the current list is finished.

#### 5.2 "STILL TIMBER TO CUT"

This message is displayed if an attempt is made to overwrite an existing cutting list. Option 3 can be used to terminate the list if required ..... see SECTION 3.3 OR another list can be selected.

#### 5.3 "TIMBER TOO SHORT"

The minimum input length on a standard machine is 1 metre. Any length less than this amount will generate the message.

#### 5.4 "I/F ROLLER DROPPED"

Infeed Roller Dropped indicates that the top pressure roller adjacent to the infeed saw has fallen between two lengths of timber and stopped the machine. The most likely cause is incorrect adjustment of the nip roller ..... see 4.7 such that the new input length fails to stay in contact with the piece already in the saw unit.

#### 5.5 "PLEASE CHECK SAW LINE CELL"

This message indicates that a problem exists with the photocell that "looks" at the infeed saw line. This cell must be cleared every time the infeed saw cycles and at the same time must be covered by timber when the machine operating sequence instructs this saw to cycle.

The message will appear if the saw line cell is obstructed by offcuts OR saw dust at trailing trim. Similarly if for some reason the input timber is mismeasured, the trailing end of the length could pass the infeed saw line before the saw cycles.

#### 5.6 "MEASUREMENT ERROR"

This can occur when the timber length moves to leading trim. The machine sequence, with a new input length, is such that as the length moves to leading trim one of the photocells on the infeed table must be uncovered by the back end of the timber before leading trim is reached. If this fails to happen, the message will appear on the VDU and the machine will stop.

SECTION FIVE

5.7 "DRIVE CREEP"

This message indicates that the drive rollers are still rotating when either of the saws are about to cycle. The machine will stop. Further reference should be made to the MPST4 Service Handbook regarding this problem, and persistent difficulties with items ..... 5.5 and 5.6

## SECTION SIX

### 6.0 ANCILLIARY EQUIPMENT

Various pieces of peripheral equipment are available for the MPS14/0. Most of these are automatic in operation and require no additional commands from the operator since it is usual to establish the method of operation at the time of machine order, with a Customer. These facilities are thus "built in" to the machine program.

The equipment currently available is as follows :-

#### 6.1 INK JET PRINTER

This unit is usually fitted to the outfeed conveyor and will identify lengths by printing a message on them. The message is automatically transmitted by the machine microprocessor to the printer control unit. This will either be the actual length of the cut piece OR a pre-determined code such as the Job Number. A cut piece not marked will be a recycle length. The height of the printer should be set to be between 10mm. - 15mm. above the timber.

The printer will require careful maintenance and this is outlined in handbook supplied with the unit.

#### 6.2 SPRAY COLOUR MARKING

There are three versions of this attachment, 3 head, 4 head OR 5 head to provide colour codes to identify 7, 15 OR 31 different lengths respectively. The operator when entering the cutting list can type in after each length, which of the spray heads is to be activated for that particular length. The position of the colours in the spray heads is left to the operator. Recycle lengths will not be sprayed.

At the end of the working day the heads should be purged to clear the nozzles of any remaining ink, using the purge button.

#### 6.3 OUTFEED DISPLAY

A third method of length identification can be in the form of a digital display that simply shows the length in millimetres as each piece is cut. This item is positioned adjacent to the outfeed of the machine such that it is visible to the operator stacking the timber lengths.

#### 6.4 HARD COPY PRINTER

Any report information displayed on the VDU can be printed for a permanent record if a printer unit is connected to the machine processor.

The pushbutton on the KEYBOARD ..... see (KEYBOARD DRAWING) can be pressed at any time and a printout will be produced of whatever is displayed on the screen at the time. .... see Page D.

It should be noted that if the MPS14/0 is in operation at this time, since the printer is slower than the machine, there may be differences between the output quantity in the lower half of the report to the sum of the cut lengths in the top half. If this is likely to cause confusion, do not feed timber whilst the printout is taken.

## SECTION SIX

### 6.5 TAPE INPUT

Machines with a cassette reader fitted .....(see 2.14) to the control panel can have cutting list information fed into the microprocessor from a mini-cassette tape. The information on the tape can be prepared on other equipment (assuming the format is compatible) OR using the MPS14 keyboard and VDU.

The tape input facility can be applied when a long cutting list is used repeatedly, or if an incomplete list has to be retained for completion at a later date. The facility can also be used to store cutting list information when the machine is switched off at night, and re-entered the following day.

The procedure is as follows :-

6.5.1 When entering a cutting list, Option 1 is selected and the VDU will display :-

"INPUT FROM TAPE - Y OR N"

If N is typed in, the cutting list entry format is as detailed in ..... SECTION 3.1.

Typing Y will automatically load a cutting list from the cassette and the list so entered will be displayed on the screen.

If the tape is part way forward wound, or at the end of the list, the system will rewind to the beginning of the tape and commence loading.

6.5.2 To save a cutting list on cassette, select Option 1. The VDU will display "OUTPUT TO TAPE Y OR N". Entering Y will rewind the tape as necessary and record the cutting list information onto the cassette. Any existing information on the tape will be erased. The quantity requirement for each length will be as originally entered. Only one cutting list can be recorded on each side of a cassette.

6.5.3 If a cutting list is unfinished when Option 1 is selected and N is entered, when "OUTPUT TO TAPE" appears on the VDU, the message "STILL TIMBER TO CUT" is displayed. .... see SECTION 5.2.

If the cutting list is finished and N is typed in, the old list can be recovered ..... see SECTION 3.3.

N.B. Cassettes and the cassette reader are vulnerable to damage through accumulation of dust. Always store the cassette in the box supplied, and always keep the cassette reader door closed. Cassette tapes as with domestic audio tapes are prone to permanent damage through exposure to extremes of temperature.

## SECTION SIX

### 6.5 TAPE INPUT ..... CONTD.

#### 6.5.4 ERROR MESSAGES DURING CASSETTE LOADING

There are two messages that can appear on the VDU during cassette use.

1) "Tape Error" - The most likely cause of this fault is either the cassette reader door has been left open OR the "write enable" plug is missing from the cassette itself. (The write enable plug when in position allows information to be recorded on the cassette tape. Removal of this plug will prevent accidental erasure of the tape and intentional recording).

2) "Checksum Error" - This can indicate a data error on the recorded tape in the form of invalid OR corrupted information. The message will also appear if a cutting list for the "optimisation" mode is loaded whilst the machine is in the "packaged to length" mode, and vice-versa.