

**WADKIN LTD**

**NE**

**UNIVERSAL CUTTER GRINDER**

**Operating & Maintenance Instructions**

**Including Parts List**

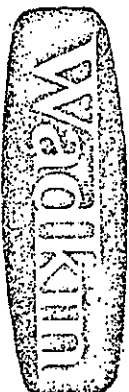

SPARE PARTS BOOKLET

CONTENTS

1. Basic ordering requirements.
2. Sample type order.
3. List of item numbers and description of item.
4. Drawing showing item numbers.

12" & 24" NH

CUTTER GRINDER

SPARE PARTS

Should spare parts be required due to breakage or wear full particulars including the machine and test number must be given. This information is on the nameplate attached to the machine and will be similar to the picture below.

<b>WESTERN Ltd.</b>			
<b>LIVERPOOL ENGLAND</b>			
MACHINE SERIAL NO.	PD 2134		
MACHINE TEST NO.	76601		
PATTERN NO.			
VOLTAJE	5W192	CYCLRS	
400	5	50	
SEE MAINTENANCE INSTRUCTION BOOK FOR LUBRICATION DETAILS			

Please see the next page for sample detail of how to order spare parts.

SAMPLE TYPE ORDER

MACHINE: NH

MACHINE NO: 1407

TEST NO: 68975

PARTS REQUIRED

1 - NH208/NH10 CUP WHEEL GUARD

1 - NH208/NH76 REAR RACK PINION SHAFT

1 - NH208/NH158 PLUNGER FOR TABLE STOP

1 - NH209/NH36 MAIN FRAME

1 - NH209/NH91 COUPLING FOR HANDWHEEL SHAFT

12" & 24" NH MACHINE SPARE PARTS LIST

NH208/NH5	FRONT BEARING HOUSING
NH208/NH10	CUP WHEEL GUARD
NH208/NH11	COVER FOR CUP WHEEL GUARD
NH208/NH14	END CAP FOR FRONT BEARING
NH208/NH21	NUT FOR TRAVERSE MOTION
NH208/NH22	BEARING FOR CROSS TRAVERSE SCREW
NH208/NH23	CROSS TRAVERSE HANDWHEEL
NH208/NH24	L.H. TABLE STOP
NH208/NH25	R.H. TABLE STOP
NH208/NH36	MAIN FRAME
NH208/NH37	CROSS TRAVERSE SLIDE
NH208/NH39	WHEELHEAD RAM
NH208/NH40	STATOR FRAME
NH208/NH41	REAR BEARING HOUSING
NH208/NH42	TABLE
NH208/NH54	REAR FLANGE FOR CUP WHEEL
NH208/NH55	BUSH FLANGE FOR CUP WHEEL
NH208/NH58	OUTER SPACING RING FOR BEARINGS
NH208/NH59	INNER SPACING RING FOR BEARINGS
NH208/NH60	GREASE RETAINER FOR REAR BEARING
NH208/NH61	SHAFT FOR CUP WHEEL GUARD
NH208/NH70	TABLE ROLLER BUSH
NH208/NH71	SLIDE ROD FOR TABLE
NH208/NH72	RACK FOR TABLE
NH208/NH75	RACK PINION
NH208/NH76	REAR RACK PINION SHAFT
NH208/NH79	BUSH FOR RACK PINION SHAFT
NH208/NH80	SLEEVE FOR MICROMETER DIAL
NH208/NH81	REAR MICROMETER DIAL
NH208/NH82	FRONT MICROMETER DIAL
NH208/NH83	TABLE ROLLER PIN

NH208/NH86	LOCK PLATE FOR CROSS TRAVERSE SLIDE
NH208/NH93	ECCENTRIC TABLE ROLLER PIN
NH208/NH119	GRINDING SPINDLE
NH208/NH125	GUARD FOR WHEELHEAD RAM
NH208/NH127	SCALE FOR ANGULAR SETTING
NH208/NH132	WIPER PLATE
NH208/NH133	WIPER FOR SLIDE RODS
NH208/NH151	LOCKNUT FOR GRINDING SPINDLE
NH208/NH152	FRONT FLANGE FOR CUP WHEEL
NH208/NH153	FRONT RACK PINION SHAFT
NH208/NH154	BUSH FOR RACK PINION SHAFT
NH208/NH155	LIP PLATE FOR CROSS TRAVERSE SLIDE
NH208/NH156	LIP PLATE FOR CROSS TRAVERSE SLIDE
NH208/NH157	STUD FOR WHEELHEAD CLAMP
NH208/NH158	PLUNGER FOR TABLE STOP
NH208/NH159	TEE BOLT FOR TABLE STOP
NH208/NH160	WHEELHEAD CLAMP (L.H.)
NH208/NH161	WHEELHEAD CLAMP (R.H.)
NH208/NH162	GREASE PIPE FOR NUT
NH208/NH164	CROSS TRAVERSE SCREW
NH208/EKA68	COLLAR FOR SPINDLE
NH208/FG1035	FISCHER BEARING
NH208/LS863	SPRING FOR SPINDLE LOCK
NH208/N4825	BALL BEARING
NH208/OA	CLAMP NUT AND LEVER
NH208/2	SPRING
NH208/2B	HANDWHEEL
NH208/2C	BALL BEARING LOCKNUT
NH208/3	GREASE RETAINER
NH208/4	HORN HANDLE

NH208/4A	STAR HANDWHEEL
NH208/4D	TWO BALL HANDLE
NH208/6D	STAR HANDWHEEL
NH209/NH9	ELEVATING GEAR BRACKET
NH209/NH15	COVER FOR MAIN FRAME
NH209/NH16	BEARING BRACKET FOR HANDWHEEL SHAFT
NH209/NH17	HANDWHEEL FOR RAISING SHAFT
NH209/NH20	SPIRAL GEAR FOR RAISING MOTION
NH209/NH36	MAIN FRAME
NH209/NH87	LOCKNUT FOR RAISING SCREW
NH209/NH88	SPIRAL PINION FOR RAISING MOTION
NH209/NH89	HANDWHEEL SHAFT FOR RAISING MOTION
NH209/NH90	SPIRAL PINION SHAFT
NH209/NH91	COUPLING FOR HANDWHEEL SHAFT
NH209/NH92	HANDWHEEL SHAFT FOR RAISING MOTION
NH209/NH130	BUSH FOR ELEVATING GEAR BRACKET
NH209/2	HORN HANDLE
NH209/LJR1 $\frac{1}{8}$	R & M ROLLER BEARING
NH209/SKF0.8.	THRUST BEARING

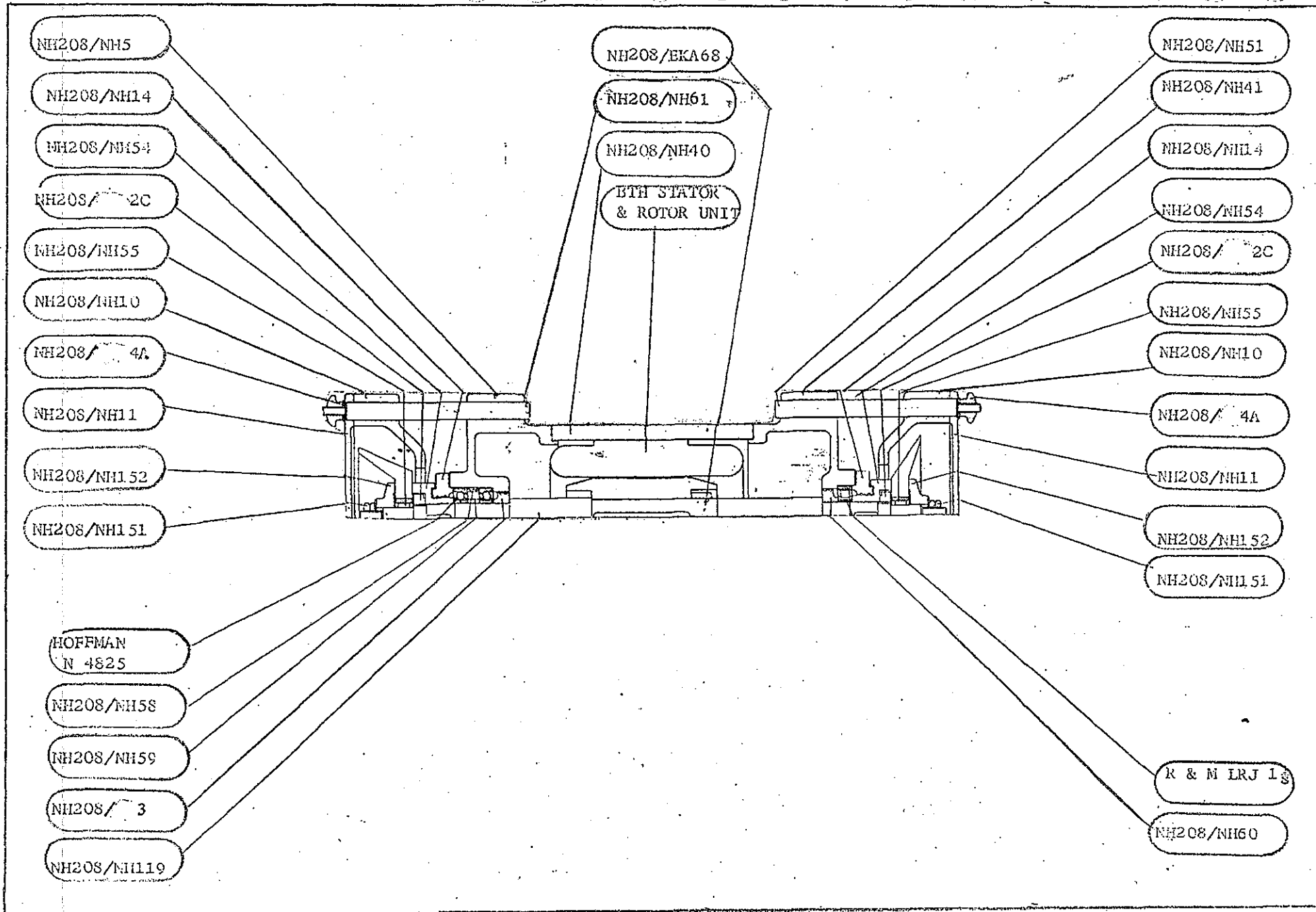

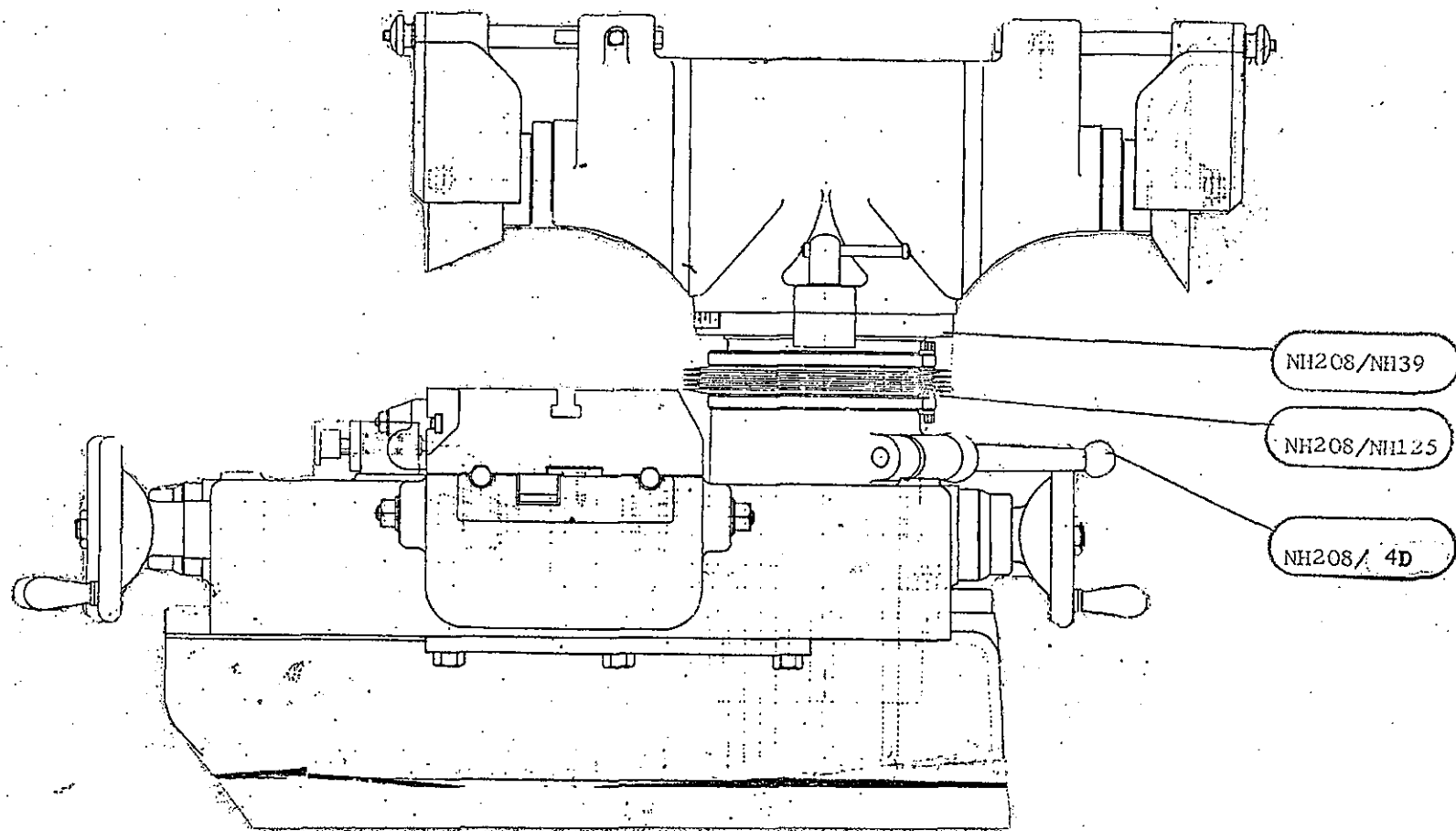

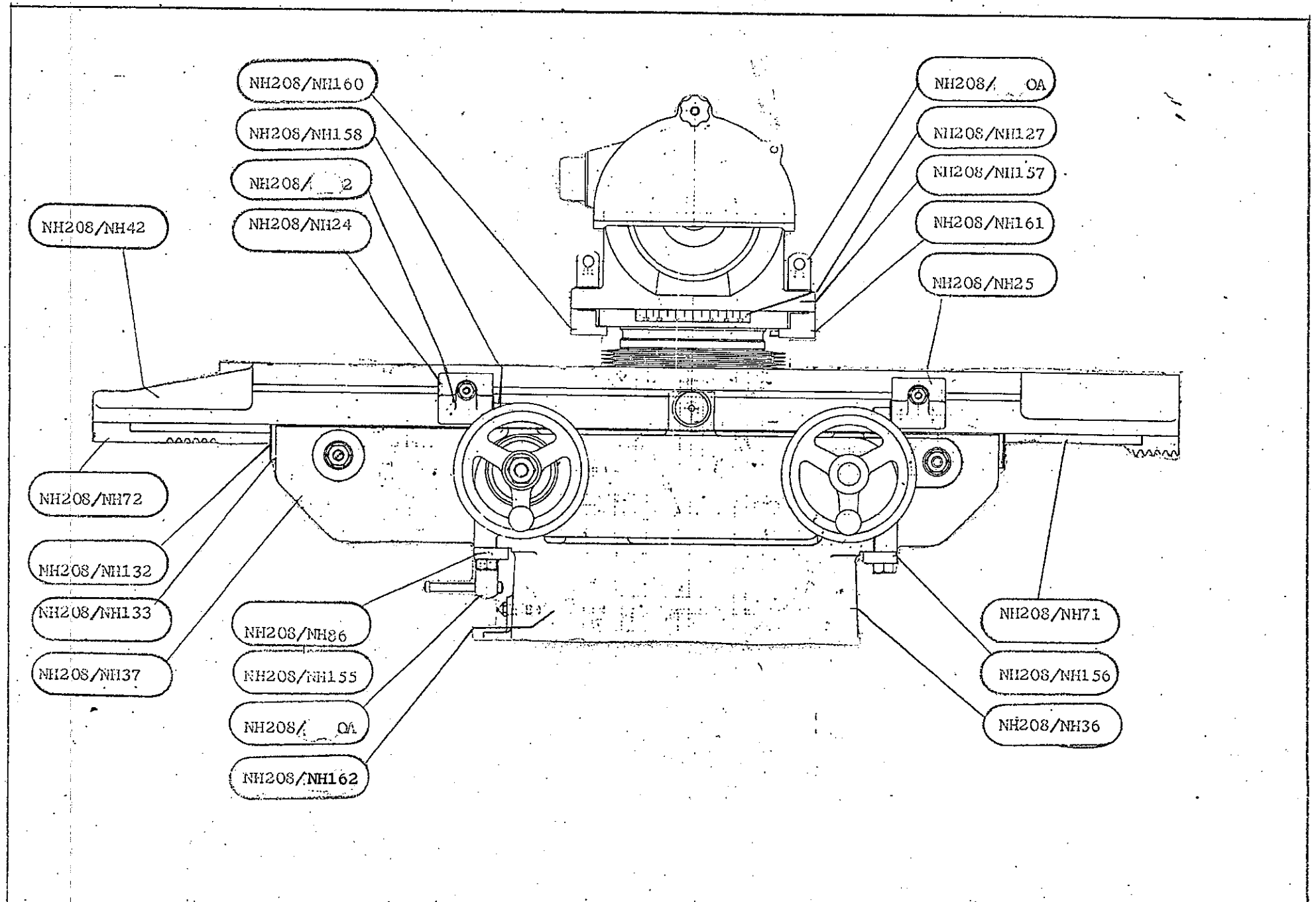

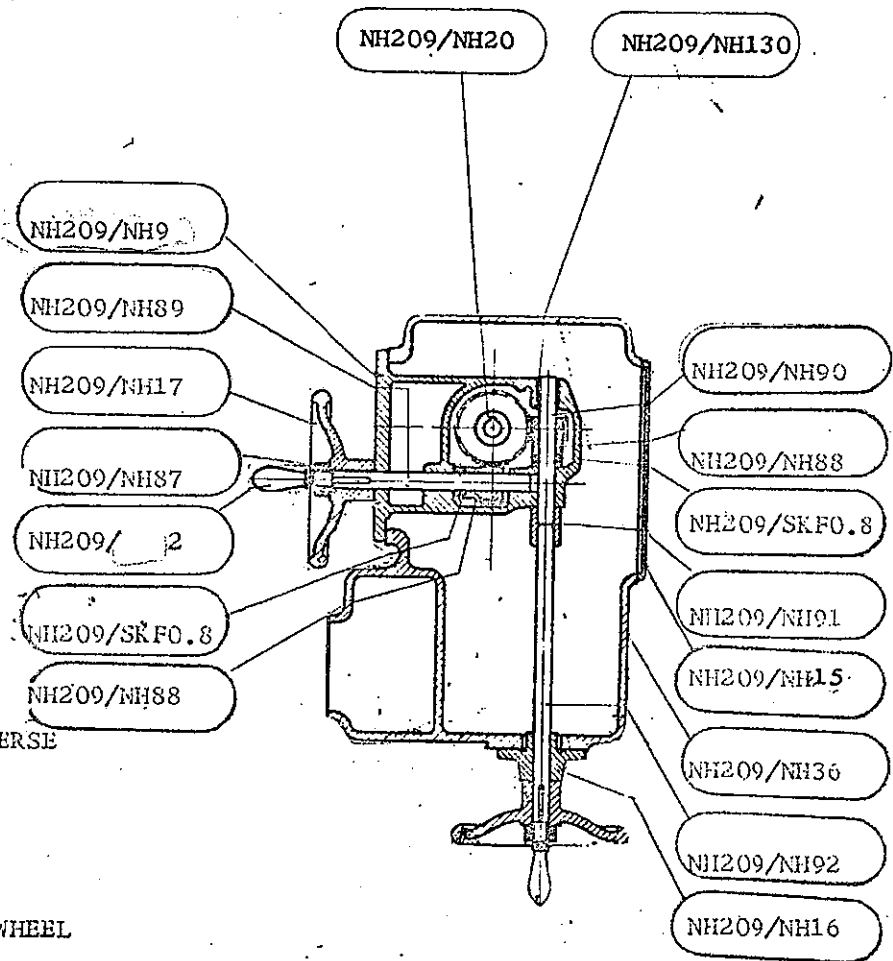
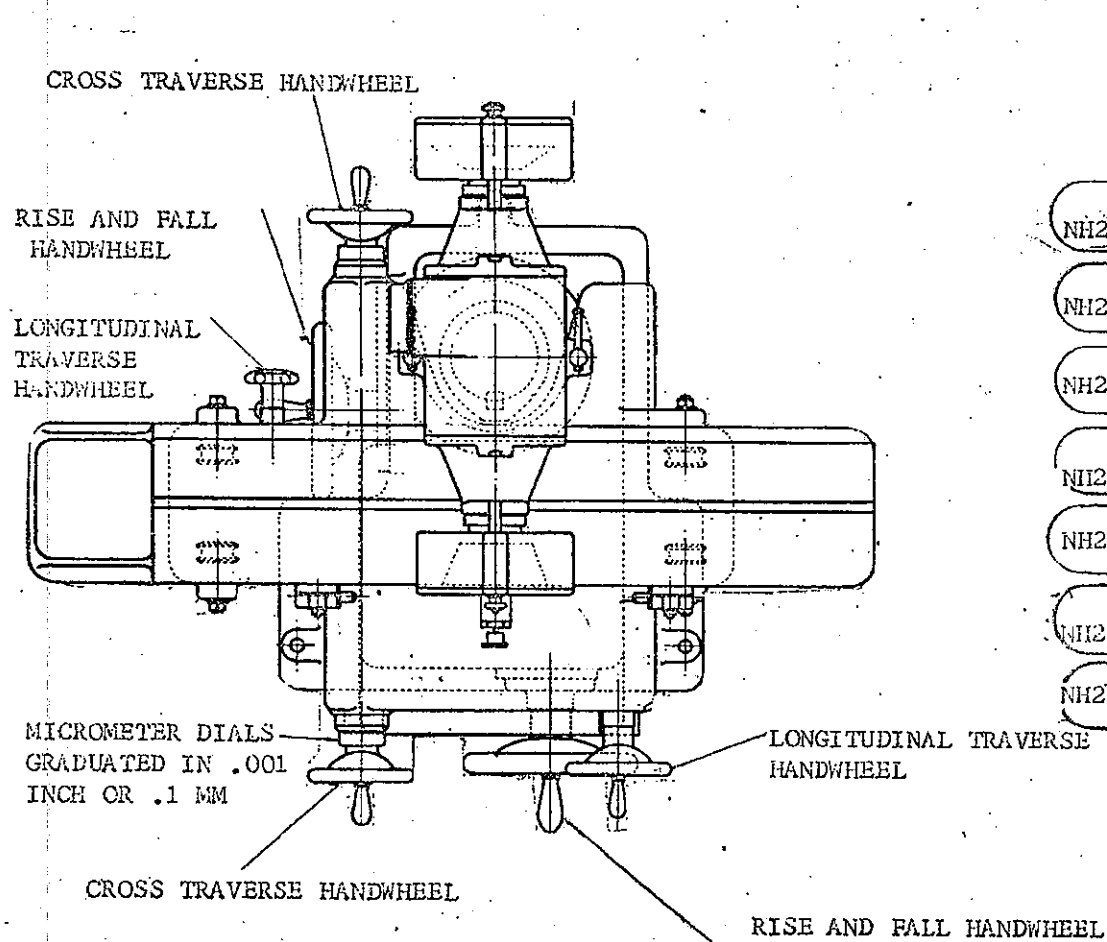

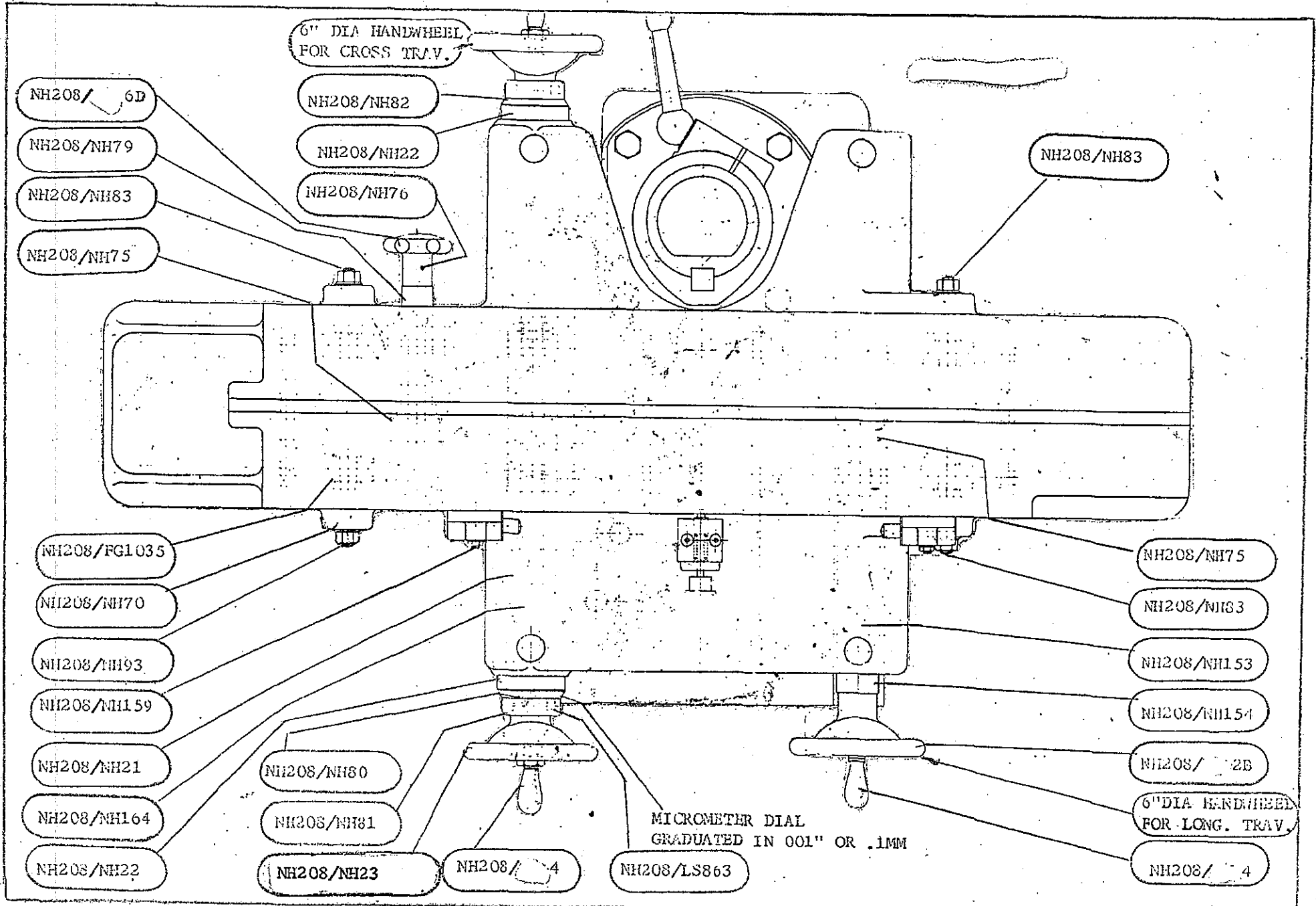

ADJUSTABLE SPRING STOPS

LOCK FOR CROSS  
TRAVERSE SLIDE

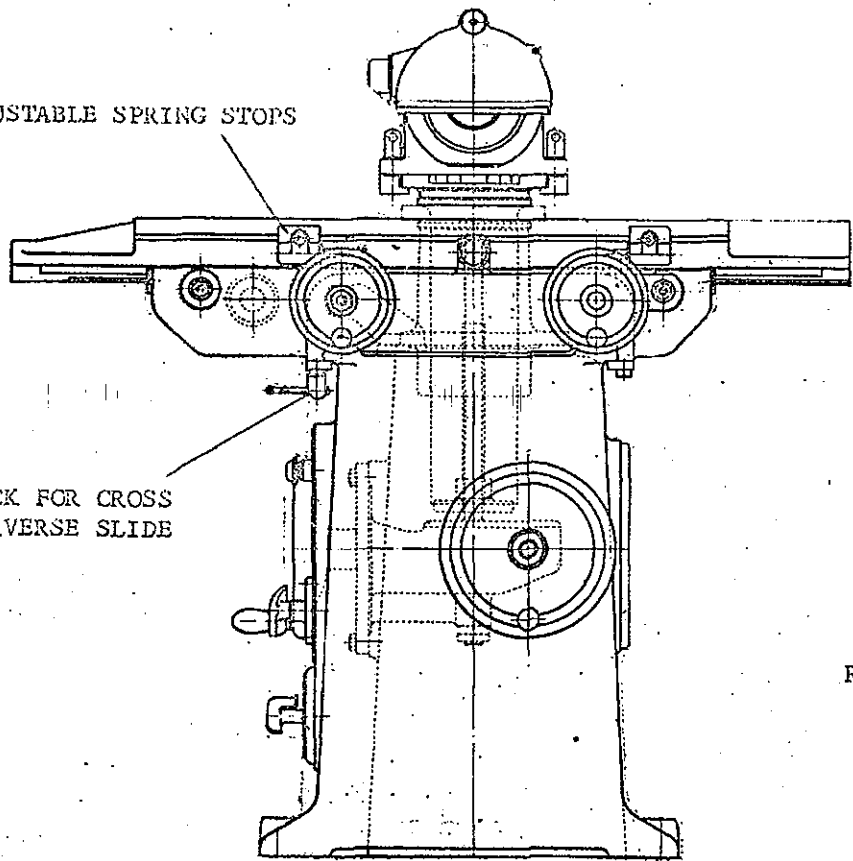

LOCK FOR RISE  
AND FALL MOTION

PUSH BUTTON STATION

REVERSING SWITCH

ISOLATING SWITCH  
(TO SPECIAL ORDER)

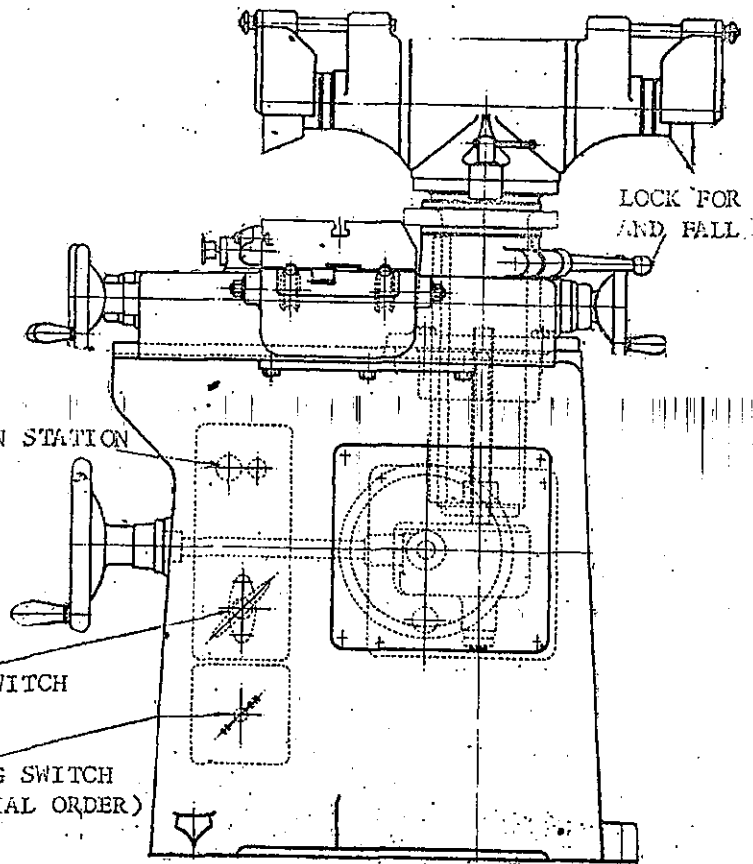

12" & 24" CUTTER GRINDER NH