



OPERATING AND MAINTENANCE
INSTRUCTIONS

SINGLE AND MULTI-RIP SAW

TYPE PYM

BOOKLET NO. 1087

SPARE PARTS

Should spare parts be required due to breakage or wear full particulars including the machine and test number must be given. This information is on the name plate behind the saw access door and should be forwarded to the SERVICE MANAGER.

Machines are occasionally modified. It is important therefore that only the book sent with the machine should be used as a working manual.

WADKIN LTD., GREEN LANE WORKS, LEICESTER, LE5 4PF, ENGLAND.

Telephone 68151

Telex 34646

SECTIONS

Section A	INSTALLATION
Section B	DESCRIPTION AND OPERATION
Section C	MAINTENANCE
Section D	ELECTRICAL EQUIPMENT
Section E	SAWS AND SLEEVES
Section F	SPARES

ILLUSTRATIONS

Section A	Fig. 1	Foundation Drawing
Section B	Fig. 1	General View of Machine
	Fig. B2	Capacity Chart
	Fig. B3	Spindle Housing rise and fall, and locking screw
	Fig. B4	Spindle Assembly
	Fig. B5	Saw Spindle
	Fig. B6	Feed Mechanism
	Fig. B7	Kick Back Fingers
	Fig. B8	Fitting Saws
	Fig. B9	Detail Drawing of Platen
Section C	Fig. C1	Lubrication Points
	Fig. C2	Feed Drive
	Fig. C3	Oil Tank
	Fig. C4	Oil Pump
	Fig. C5	Adjusting oil pump
Section D	Fig. D1	Electrical Wiring Diagram
Section E	Fig. E1	Single Saw Assembly
	Fig. E2	Sectional view of Keyway and Key dimensions
	Fig. E3	Multi Saw Assembly
	Fig. E4	Dummy Spindle
Section F	Fig. F1	Electric Blower

SINGLE AND MULTI-RIP SAW TYPE PYM

SPECIFICATION

Maximum dia. of saw-single saw	12"	315 mm
Maximum dia. of saw-multi saw	10"	250 mm
Minimum dia. of saw-multi saw	8"	200 mm
Maximum thickness of timber- single saw	3"	75 mm
Maximum thickness of timber- multi saw	2½"	64 mm
Horsepower of saw motor	20	
Optional H. P.	30	
Saw arbor length	5½"	140 mm
Minimum stock length- single saw	20"	500 mm
Minimum stock length- multi saw	14"	355 mm
Minimum spacing of saws	⅛"	3 mm
Throat capacity from centre line of track	18"	457 mm
Bore diameter of saw		60 mm
Saw spindle speeds	4500 rpm	
Optional speeds	4000 and 5000 rpm	
Size of table	5'2" x 3'0½"	1575 x 930 mm
Table width each side of track centre.	18"	457 mm
Height of track from floor level	34"	865 mm
Feed speeds infinitely variable	30 to 160 ft./min.	9 to 48 metres/min.
Horsepower of feed motor	3 h. p. at 1500 rpm 2 h. p. at 750 rpm	
Floor area	5'3" x 4'3"	1540 x 1270 mm

Details included with the machine

Saw and feed motor, control gear including ammeter. ~~One saw cleave with nut and spacing collars for single saw~~ Ratchet spanner, fence, grease gun and a tin of lubricant. One set of spanners.

Optional extras.

30 h. p. saw motor. Pulleys for 4000 or 5000 r. p. m. of saw spindle. Saws and spacing collars.

ERRATA

If the machine is used on heavy timbers it is essential to have a support roller stand at the outfeed end to prevent the timber damaging outfeed end of top roller pressure housing.

SECTION A

INSTALLATION

Clean protective coating from bright parts with cloth soaked in paraffin, turpentine or other solvent. Level table surface by packing under main base.

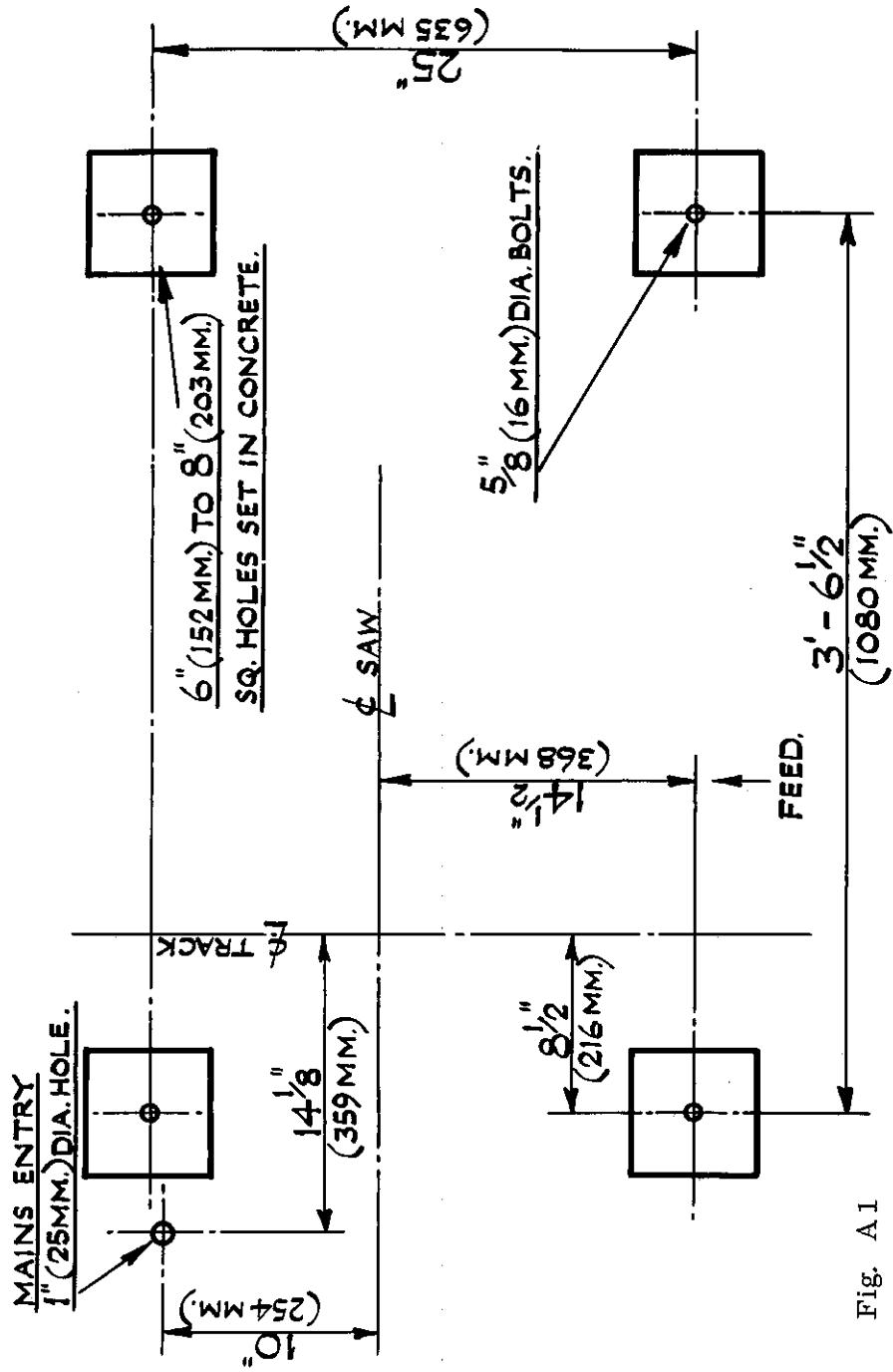

Fig. A 1

WIRING DETAILS

The motor and control gear have been wired in before despatch. All that is required is to connect the power supply to the isolating switch.

Points to note when connecting to power supply.

1. Check the voltage, phase and frequency with those on the machine plate.
2. Check the main fuses are of the correct capacity.
3. Connect the incoming supply leads to the appropriate terminals.
4. Check all connections are sound.
5. Remove saw sleeve and collars if fitted and check that the spindle rotation direction is correct, (anti-clockwise at the saw). Reverse any two of the line lead connections to reverse rotation.

It is essential that the machine is connected to a dust collecting system. The machine has a built in outlet point on the pressure beam. The connecting trunking should be flexible to allow for the rise and fall of the pressure beam of 4". See foundation drawing supplied separately.

SECTION B

DESCRIPTION AND OPERATION

1. Door for access to saws and pressure rollers.
2. Pressure roller depth stop nuts.
3. Handwheel for adjusting pressure beam.
4. Variable speed control handwheel.
5. Fence.
6. Saw spindle rise and fall screw.
7. Graduated fence rule.
8. Two speed feed selector switch.
9. Master stop button.
10. Control gear.
11. Isolator switch.
12. Ammeter and push button control panel.
13. Pressure beam.
14. Exhaust opening.
15. Side guard.
16. Oil container.
17. Anti-kick back fingers.
18. Oil pump priming handle.
19. Cover for access to saw motor terminals.
20. Dust chute.
21. Platen locking handle.

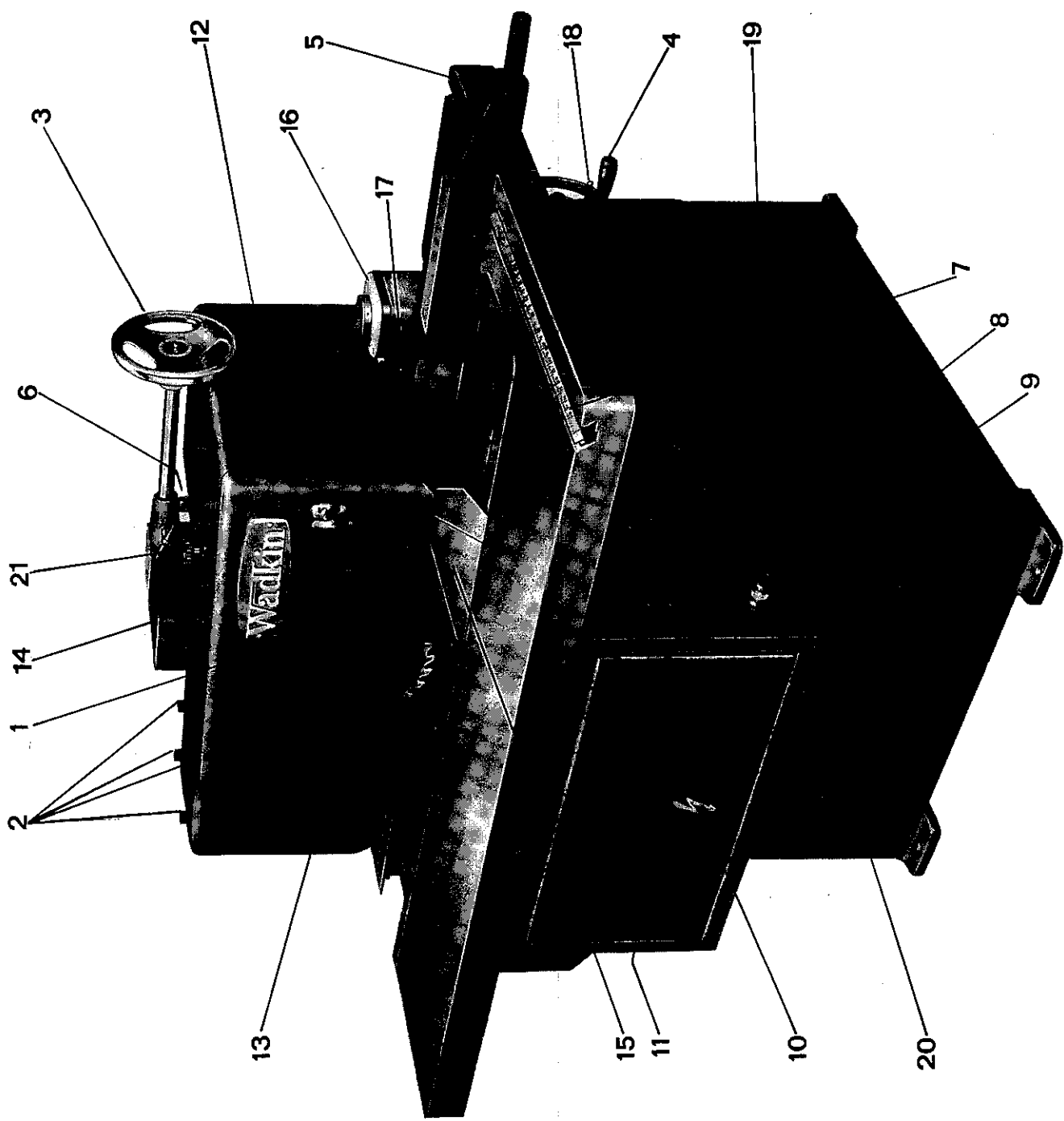
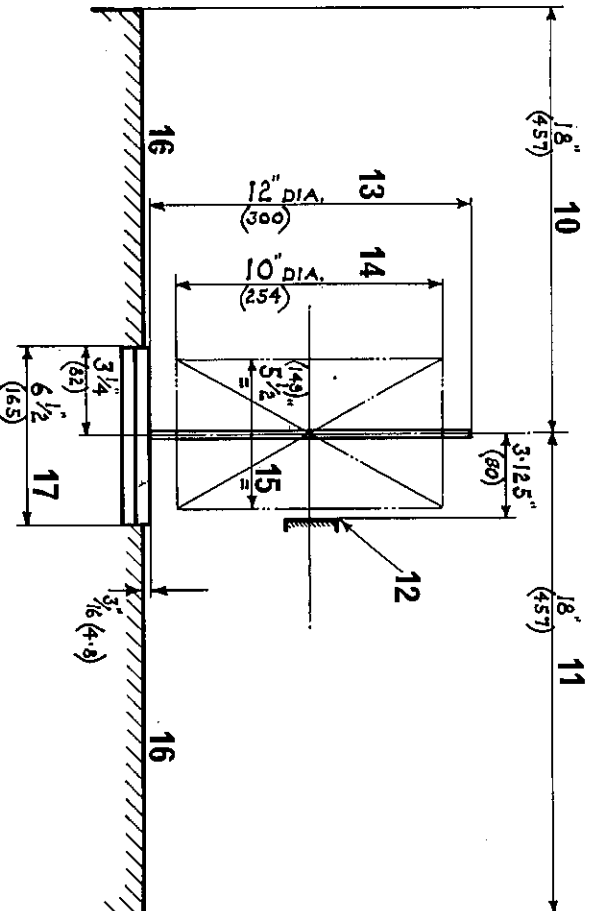
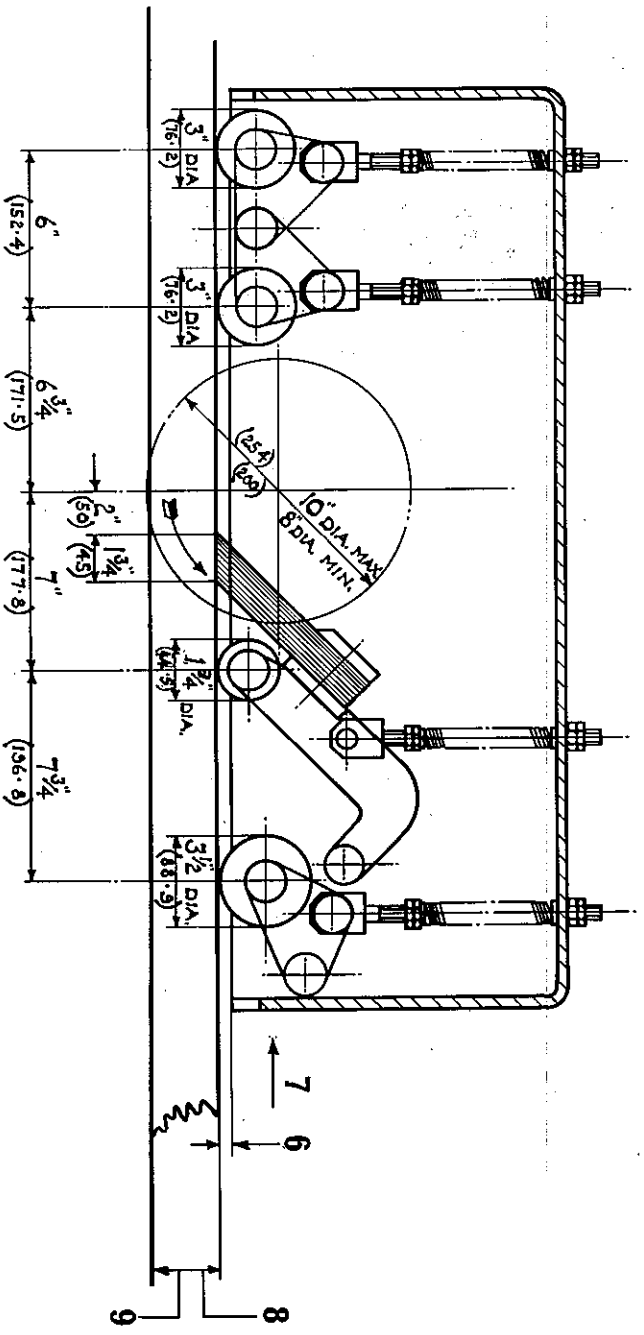
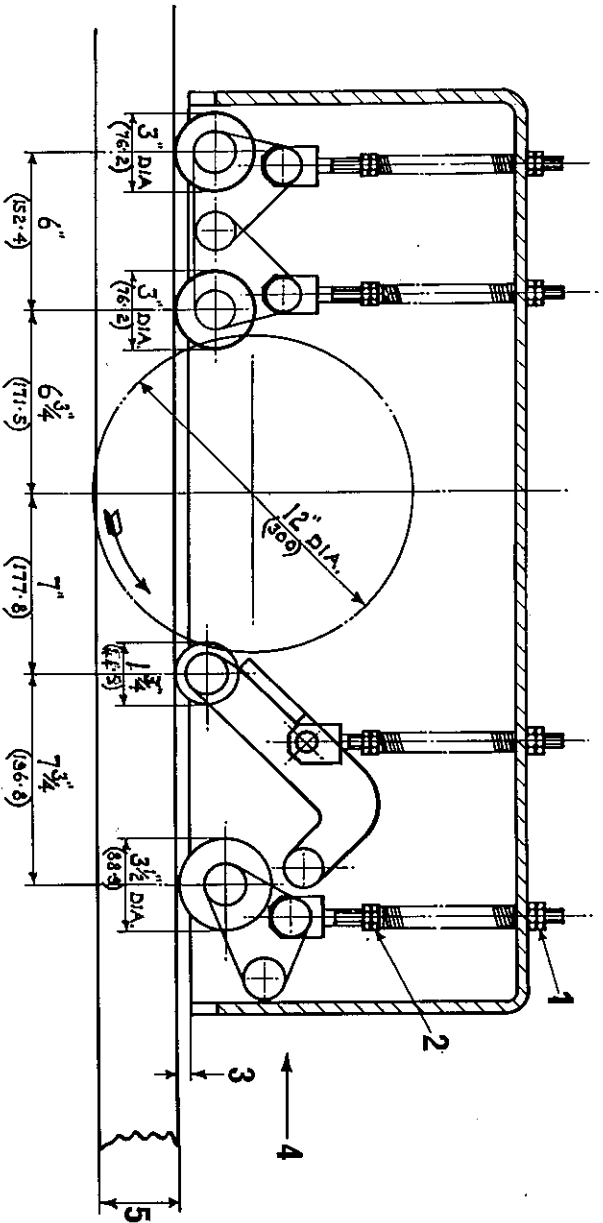

Fig. B1

Fig. B 2



B 3

CAPACITY CHART FOR SINGLE AND MULTI-RIP MACHINES (Fig. B. 2)

Capacity using Single Saw 12" (300 mm) diameter.

Pad pressure not used with 12" (300 mm) diameter saw. Minimum stock length 20" (500 mm).

1. Roller depth stop nuts.
2. Pressure adjusting nuts.
3. Rollers to be set $\frac{5}{8}$ " (15 mm) below machined face for initial lift of $\frac{1}{8}$ " (3 mm).
4. Direction of feed.
5. 3" (75 mm) nominal maximum timber thickness.

Capacity using 10" (250 mm) and 8" (200 mm) diameter Multi Saws.

Minimum stock length 14" (355 mm)

6. Rollers to be set $\frac{5}{8}$ " (15 mm) below machined face for initial lift of $\frac{1}{8}$ " (3 mm).
7. Direction of feed.
8. $2\frac{1}{2}$ " (63 mm) nominal maximum timber thickness with 10" (250 mm) diameter saws.
9. $1\frac{1}{2}$ " (38 mm) nominal maximum timber thickness with 8" (200 mm) diameter saws.

Saw width, track and throat capacity.

10. Distance from centre of track to front table edge.
11. Distance from centre of track to machine frame.
12. Locating shoulder on spindle.
13. Diameter single saw.
14. Diameter multi saw.
15. Maximum distance across inner and outer saws. (See Fig. E3.)
16. Table surface.
17. Track width.

ROLLER AND PLATEN SETTING

1. Roller depth stops (item 1 fig. B. 2.) to be adjusted to set roller $\frac{5}{8}$ " (15 mm) below beam casting.
2. Roller pressure spring tension locknuts (item 2 fig. B. 2.) to be adjusted upwards five full turns from position of zero pressure (i. e. spring just held).
3. Platen contact face to be set $\frac{1}{16}$ " (1.6 mm) lower than the roller.

THE SAW SPINDLE

The spindle is of high grade steel mounted in angular contact bearings fitted at the front and a roller bearing at the rear. The spindle housing is swing mounted giving $2\frac{3}{8}$ " (60 mm) rise and fall of the saw spindle, operated by a screw (1) Fig. B. 3. A lock (2) Fig. B. 3 is fitted to clamp the housing to the pressure beam overarm. The lock must be applied when the machine is in use.

<u>Spindle Assembly Fig. B. 4.</u>		<u>Saw Spindle Fig. B. 5.</u>	
1.	Saw Carriage	1.	Spindle Nut
2.	Pivot Spindle	2.	Key
3.	Locking Bolt	3.	Bearing Locknut
4.	Locking Nut	4.	End Cap
5.	Rise and fall nut	5.	Angular Contact Bearings
6.	Trunnion	6.	Outer Spacer
7.	Rise and Fall Screw	7.	Inner Spacer
8.	Thrust Washer	8.	Spindle
9.	Bush	9.	Grease Retainer
10.	Collar	10.	Roller Bearing
11.	Pin	11.	Yoke
		12.	End Cap
		13.	Locknut
		14.	Spindle pulley.

Alternative pulleys can be fitted to the spindle to give speeds of 4000 and 5000 r. p. m. Care must be taken to ensure that the pulleys locate up to the shoulder provided to keep the belts running true to the motor pulley. Tension to the belts can be adjusted with the turnbuckle situated midway between the saw motor and spindle. There should be approximately $\frac{1}{2}$ " (12 mm) of play in the belts. Access is through removable panel at the rear of the machine

SPINDLE BEARINGS

It is essential that the bearings are not over lubricated as overheating of the bearings occurs. Should dismantling of the bearings be necessary the following points should be noted. The bearings and bearing houses should be washed out in clean petrol. On reassembling pack the bearing and housing half full of clean grease of the appropriate grade. All parts should be kept strictly clean whilst reassembling. Note particularly the correct assembly of the front bearings on Fig. B. 5.

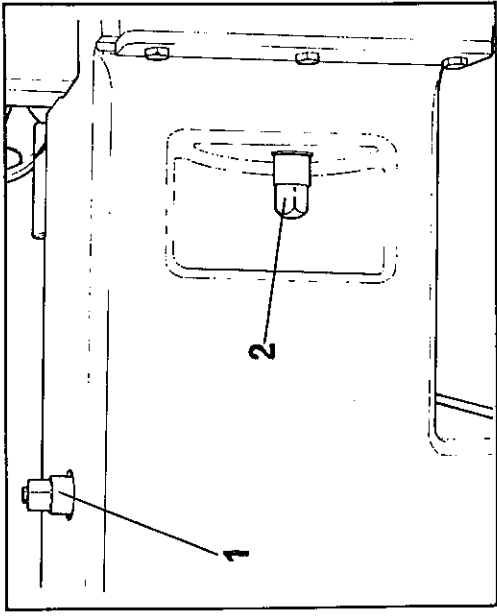

Fig. B3

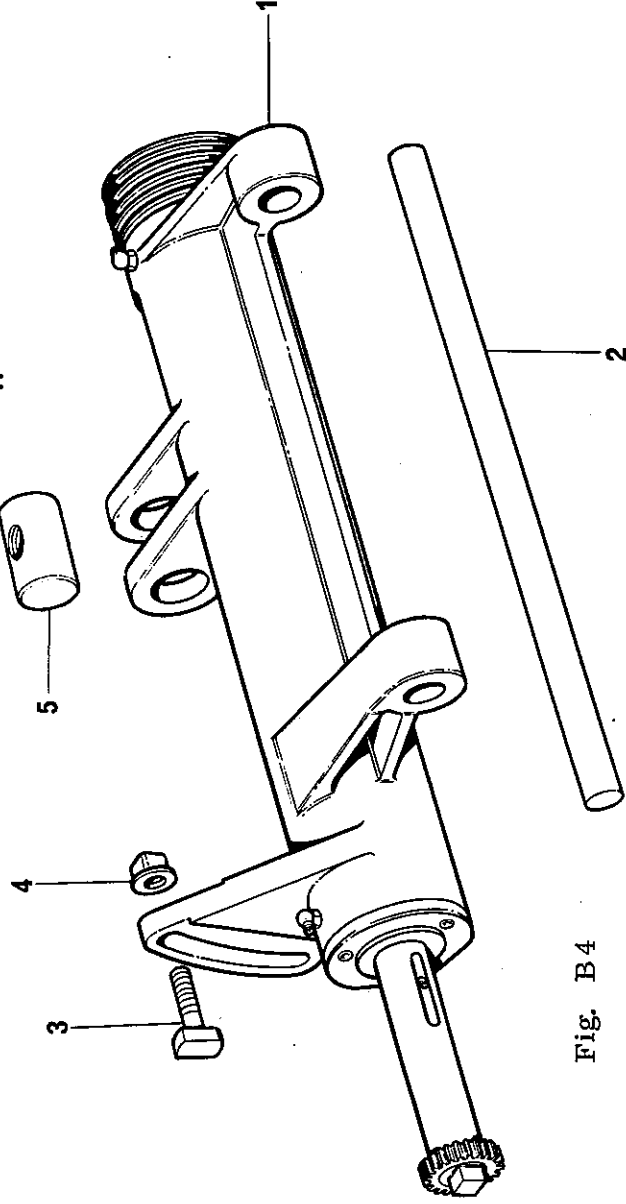
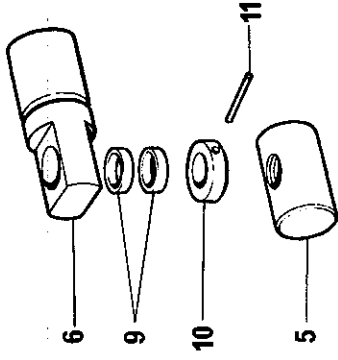
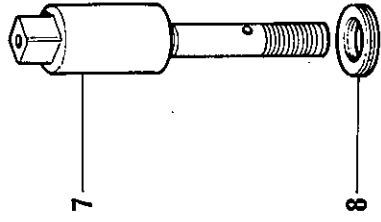

Fig. B4

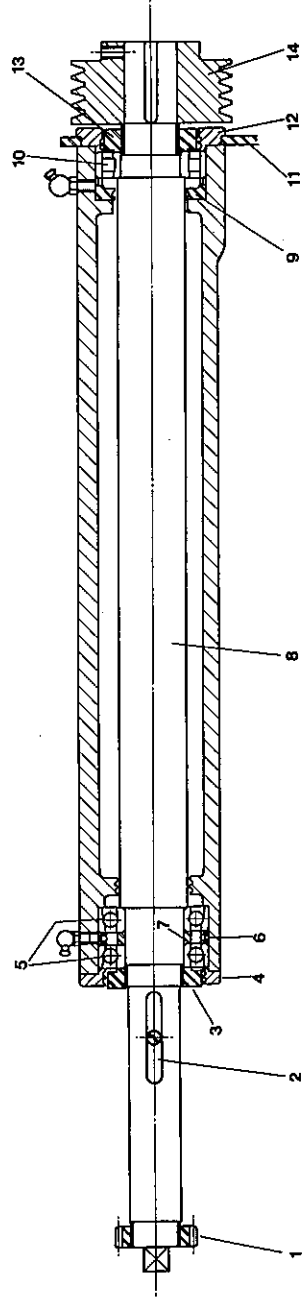

Fig. B5

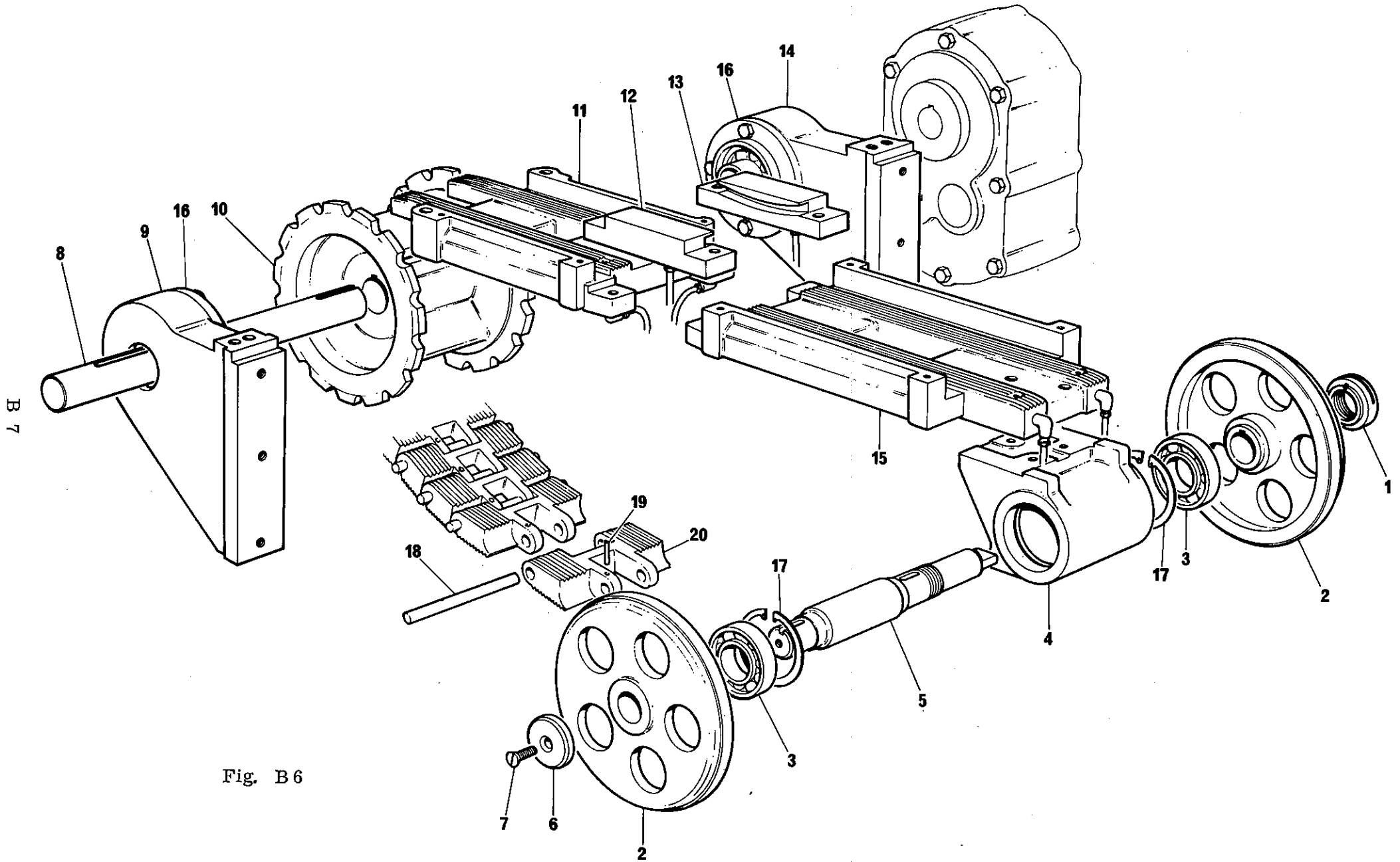

Fig. B 6

FEED DRIVE CHAIN (Fig. B. 6)

To split the chain, knock out the tension pin (19) of a link and drive out the link pin (18) using a soft metal drift. Care should be taken because the pins are hardened and chipping of the pin could occur. Thoroughly clean down the underside of the chain and wash in paraffin. Before refitting rotate the oil pump handle to ensure that the oil pipes and lubricating holes are not blocked or partially restricted.

On assembly ensure that the hole in the pin (18) is in line with the hole in the link (20) before refitting the tension pin (19). New tension pins only should be used.

1.	Locknut	11.	Chain Slide Outfeed
2.	Chain Idler Roller	12.	L. H. Chain Dip Guide
3.	Bearings	13.	R. H. Chain Dip Guide
4.	Idler Bearing Housing	14.	Support Bracket
5.	Spindle	15.	Chain Slide Infeed
6.	Washer	16.	Bearing Assembly
7.	Locking Screw	17.	Circlip
8.	Drive Shaft	18.	Chain Link Pin
9.	Support Bracket	19.	Tension Pin
10.	Drive Chainwheel	20.	Chain Link

ANTI-KICK-BACK PROTECTION

Three separate anti-kick-back devices are incorporated.

Carried on the pressure beam and rising and falling with it are anti-kick-back sprags (2) Fig. B. 7, to restrain the work piece from rearwards ejection, and to stop flying splinters.

A curtain of fingers (1) Fig. B. 7 is fixed in height and closes the gap around the work-piece to stop flying splinters.

Telescopic guard plates (4) Fig. B. 7. prevent splinters being thrown out sideways.

THE FENCE

The scale mounted in the fence slot is set zero to the centre of the track. That is $3\frac{1}{8}$ " (80 mm) from the locating shoulder of the saw spindle.

THE AMMETER

The ammeter, (5) Fig. B. 7, mounted in the push button panel indicates the power being absorbed by the saws. The needle should not read in the red section.

The ammeter readings give a good indication when the saws require resharpening indicated by a pronounced increase in power absorbed.

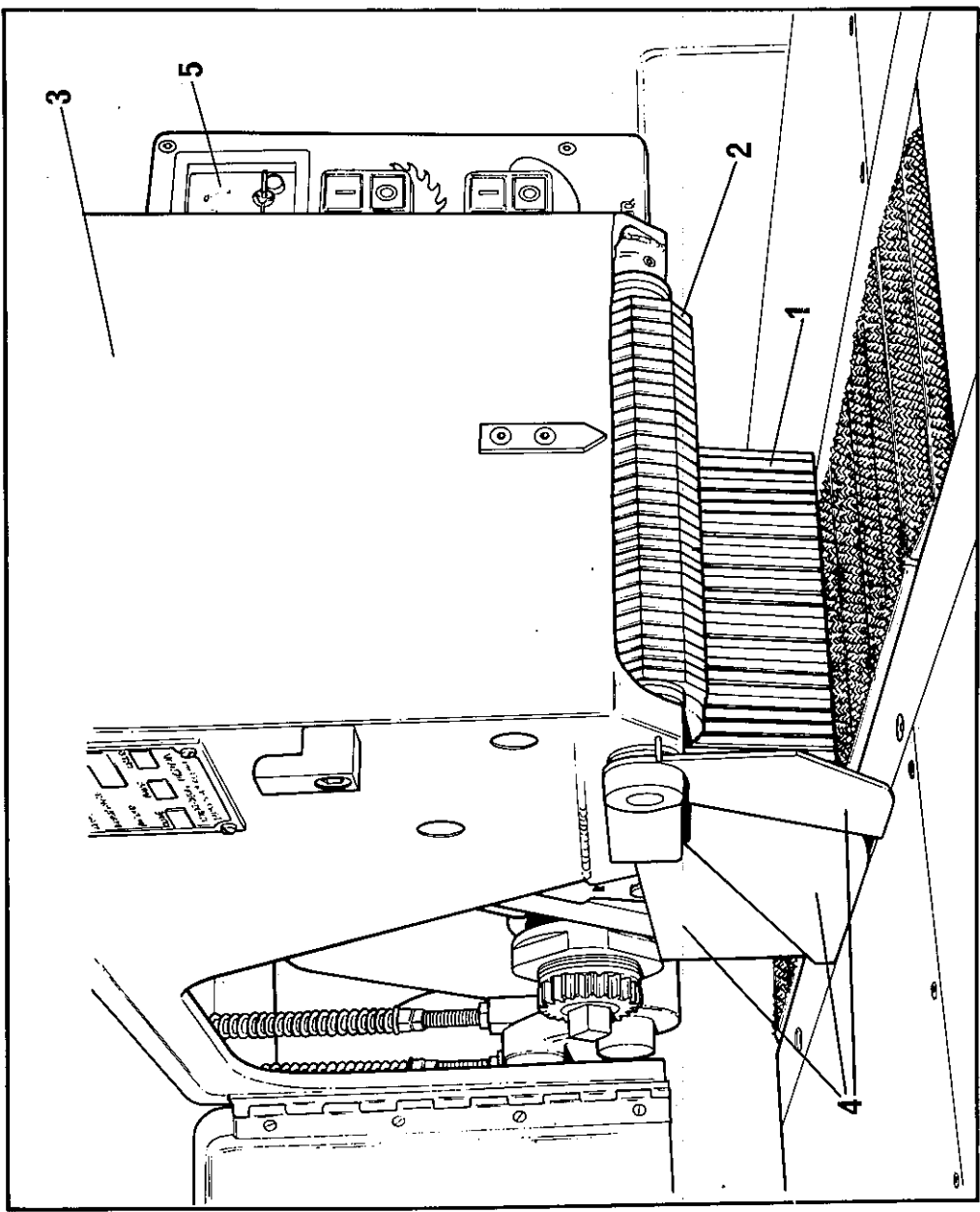
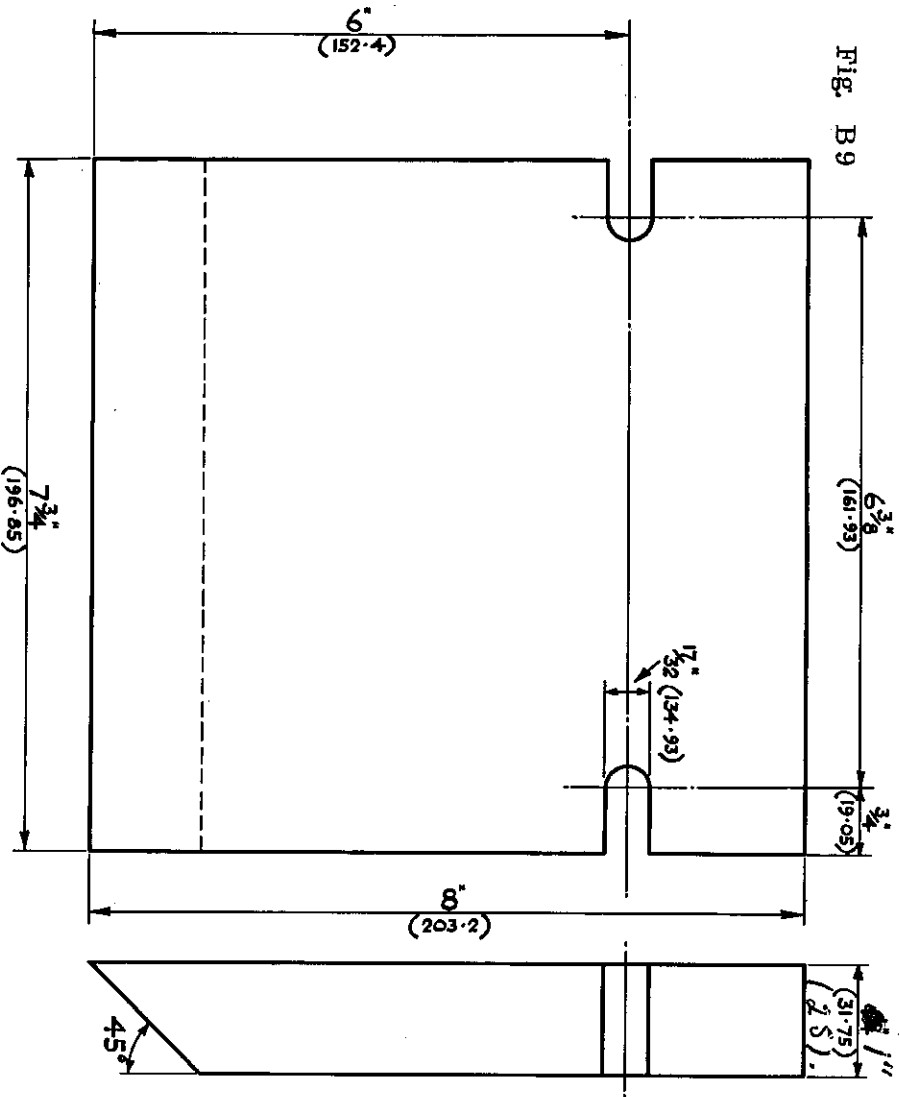
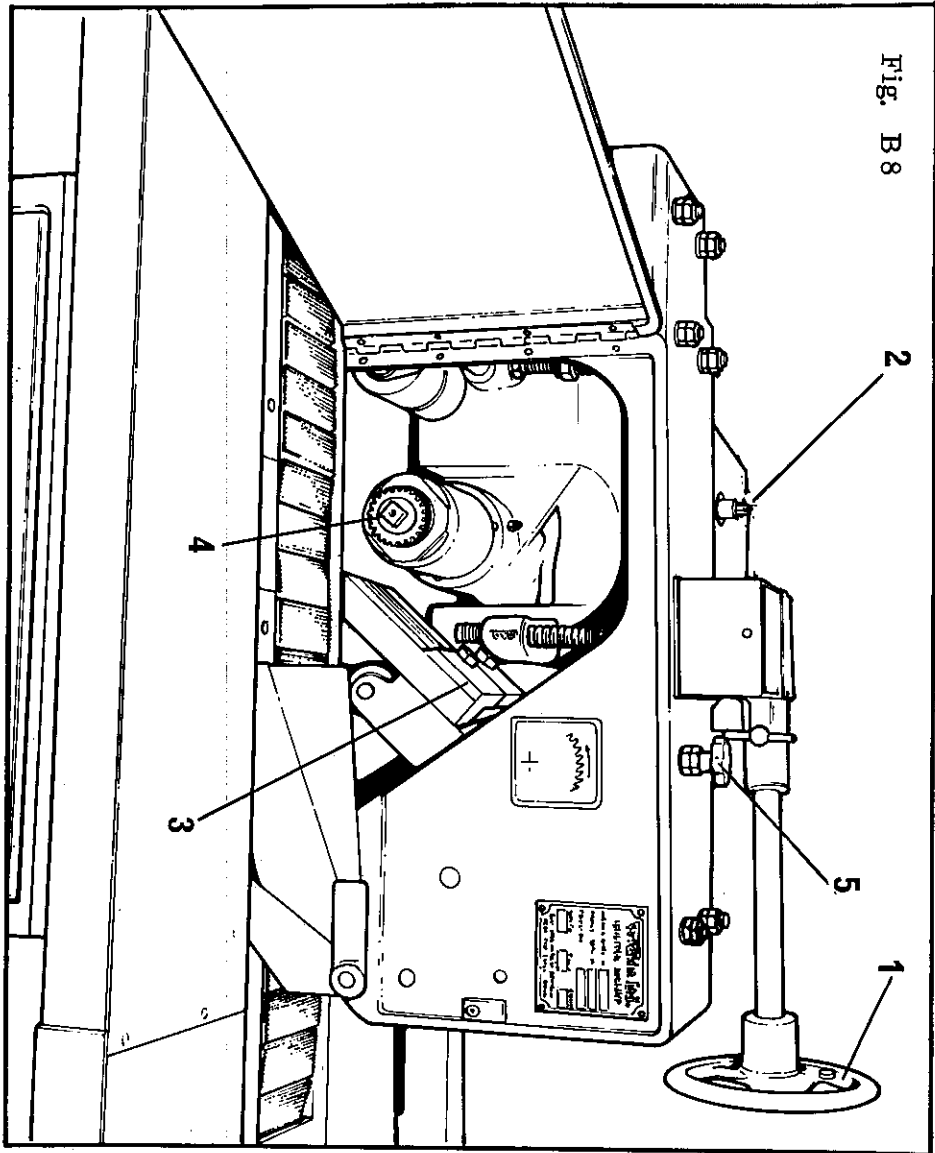

Fig. B7



FITTING SAWS (Fig. B. 8 and Fig. B. 9)

When fitting saws on to the machine proceed as follows

1. Isolate electrics and open pressure beam door.
2. Lower pressure beam to lowest position by use of handwheel (1).
3. Raise saw spindle to top position by ratchet spanner on raising screw (2) after releasing lock.

Multi-Saws

4. Fit wooden platen (Fig. B. 9) by means of screws and clamp plate (3).
5. Clean the saw spindle and locknut face. Slide on the gang of saws ensuring that the sleeve is properly located up to the locknut face. Fit the spindle gear nut (4). Lock up with the spanners provided do not over tighten. Rotate the spindle by hand to ensure it is free and the saws run true.
6. Lock Platen in position by small handwheel (5) on top of pressure box.
7. Start saw spindle.
8. Raise pressure beam to top position i. e. 3" (75 mm) above track.
9. Lower saw spindle to cutting position i. e. saw $\frac{1}{8}$ " (3 mm) below track level and lock in position.
10. Lower pressure beam to working position and lock.
11. Lower platen to working position i. e. until handwheel (5) is free.
12. Stop saw.

Single Saw

13. Lower pressure beam to approx. 1" (25 mm) from track by use of handwheel (1).
14. Raise saw spindle to top position by ratchet spanner on raising screws (2) after releasing lock.
15. Clean saw spindle and locknut face. Slide on the sleeve with saw in position ensuring that the spacing collars marked 'back' and 'front' are in their correct positions. Fit the spindle gear nut (4). Lock up with spanners provided. Do not over tighten. Rotate the spindle by hand to ensure it is free and the saw runs true.
16. Lower saw spindle to cutting position i. e. saw $\frac{1}{8}$ " (3 mm) below track level and lock in position.
17. Raise pressure beam to working position and lock.

When using the machine for single sawing with 12" (300 mm) dia. saw the platen clamp plate must be removed.

SECTION C

MAINTENANCE

DAILY

1. Check oil level in tank. Fig. C1. point B.
2. Clean the face of the feed chains with a wire brush.
3. Prime the pump each morning before starting track by rotating the handle 6 times.

WEEKLY

4. Clean down machine.
5. Clean inside body.
6. Oil slides using Wadkin oil L4. Fig. C. 1. point A.
7. Oil pressure beam raising screw using Wadkin oil L4. Fig. C. 1. Inset Point E.
8. Oil saw spindle raising screw using Wadkin oil L4. Fig. C. 1. Point D.
9. Grease variable speed pulley using Wadkin grease L6. Fig. C. 2. Point A.
10. If the feed has been run continuously at one speed adjust the feed speed through the full range of the scale whilst the feed is running.
11. Check machine setting i. e. depth stops, pressure springs. (see page B. 4.)

MONTHLY

12. Check spindle drive belt tension. (see page B. 5.)
13. Check condition of spindle drive belts.
14. Check condition of variable feed speed belt.

3 MONTHLY

15. Grease spindle bearings with 4 charges of grease gun using Wadkin grease L6. Fig. C. 1. inset Point F.
16. Smear the mitre gears with Wadkin grease L6. Fig. C. 2. Point C.
17. Check oil level in torque arm reduction gearbox by filling up to level of plug with Wadkin oil L4. Fig. C. 2. Point B. Access is reached by removing the rectangular inspection cover on the outfeed end of the machine.

6 MONTHLY

18. Remove the feed chain and clean the chain, the chain trackway, and the sprocket. For stripping and reassembly instructions refer to page B. 8.

WADKIN OILS AND GREASES WITH RECOMMENDED ALTERNATIVES

WADKIN GRADE	CASTROL	B. P.	SHELL	MOBIL	ESSO	GULF	CALTEX
L4	Perfecto NN	Energol CS 100	Vitreia 33	Vactra Oil Heavy Medium	Esstic 50	Security 53	Ursa P20
L6	Sphaerol AP3	Energrease LS	Alvania Grease No. 3.	Mobilux Grease No. 3.	Beacon 3	Gulferown Grease No. 3	Regal Starfak Premium

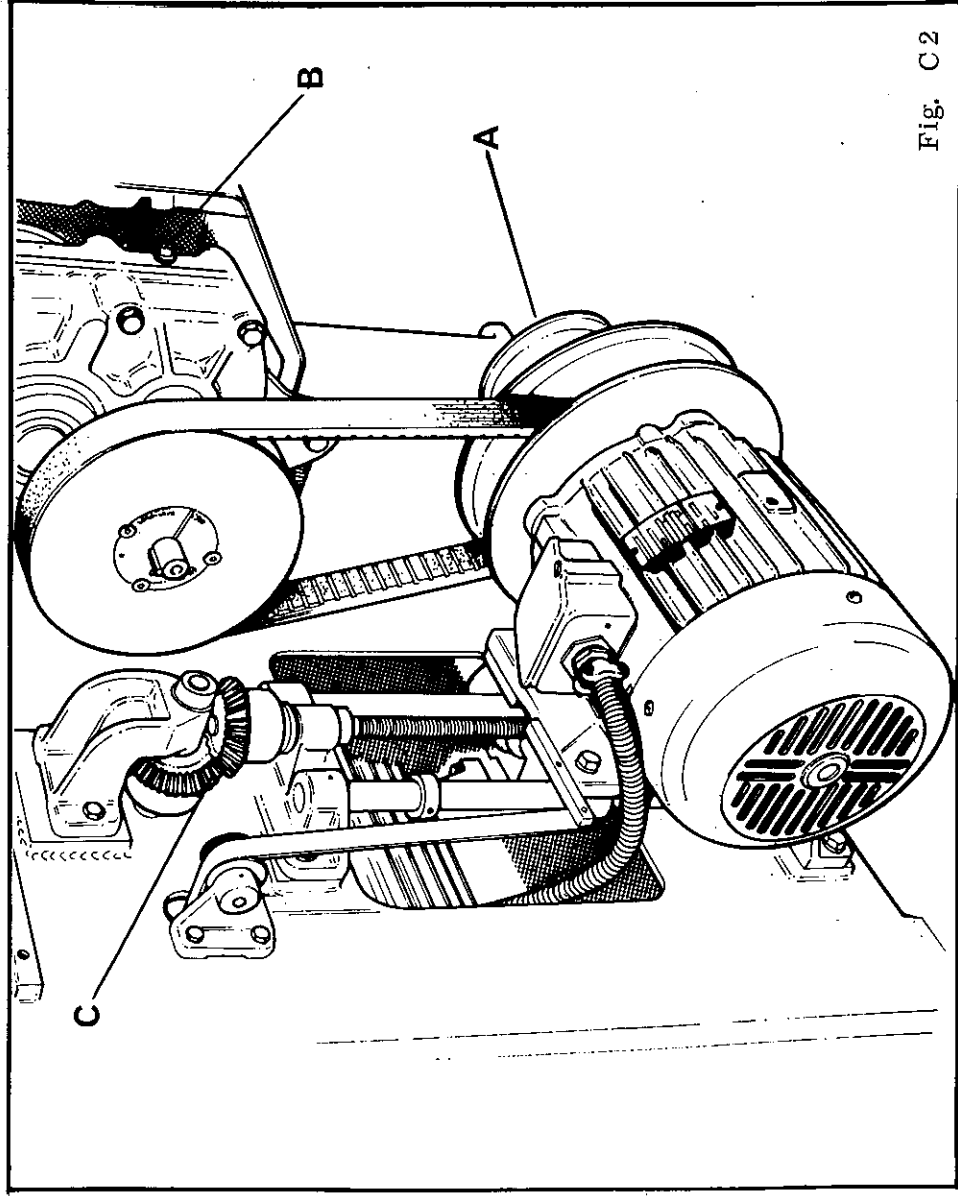
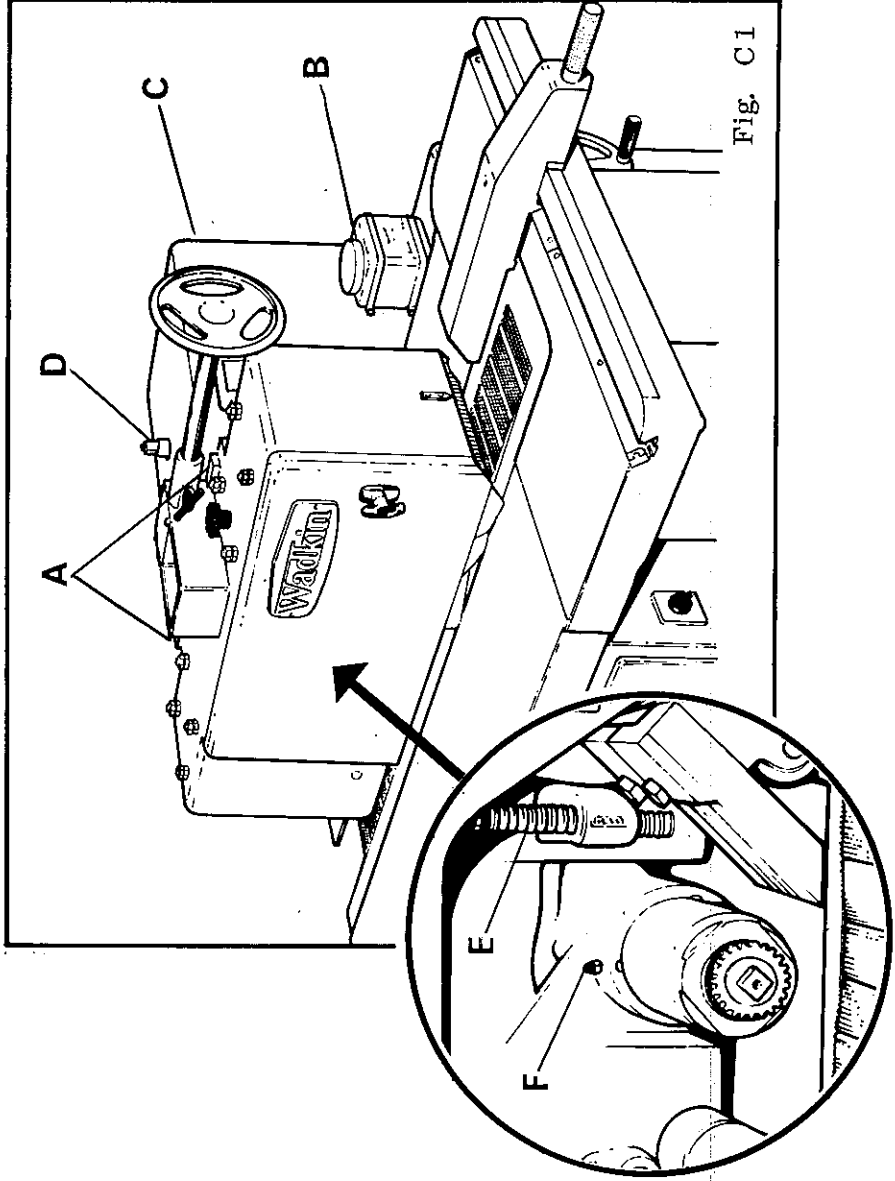

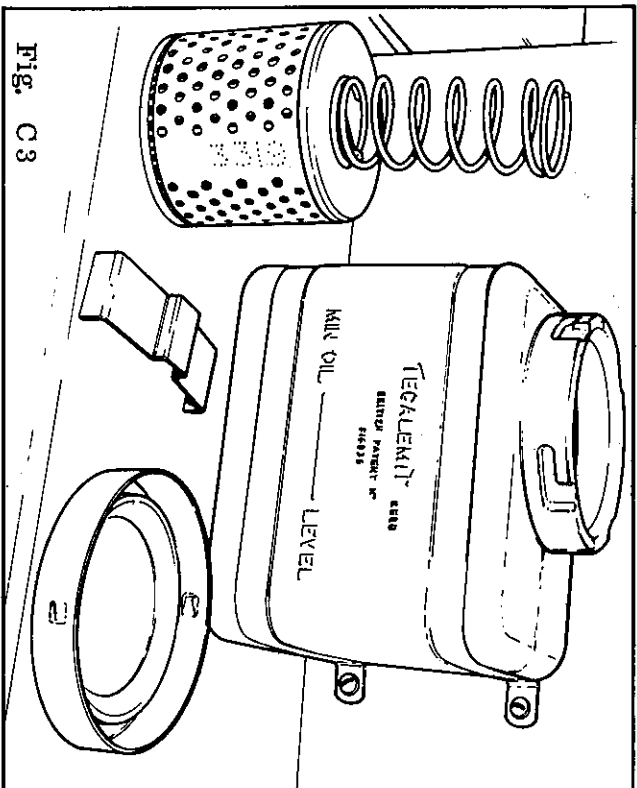

Fig. C3

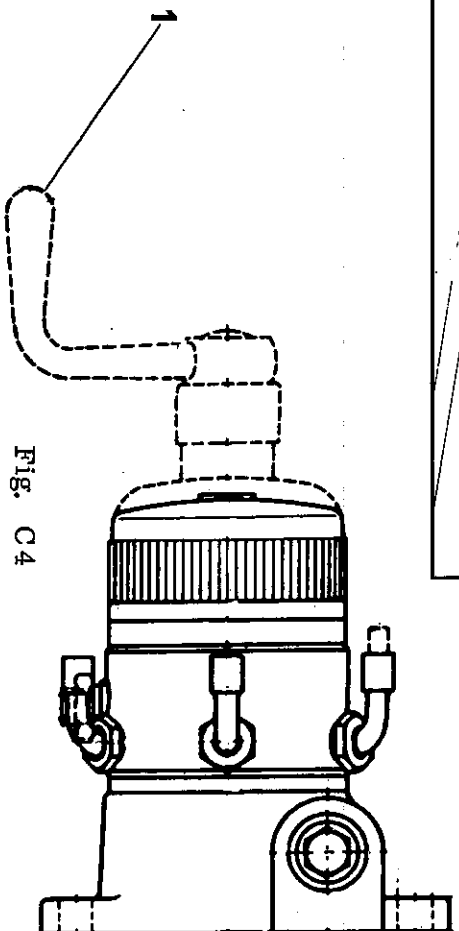

Fig. C4

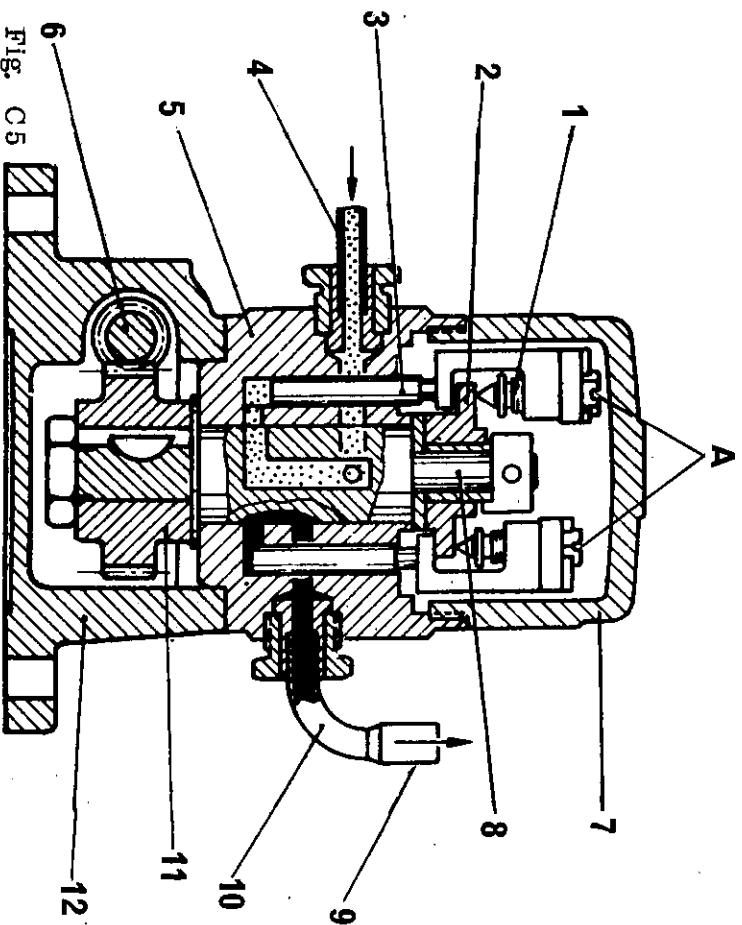

Fig. C5

C 3

LUBRICATION (Cont.)

OIL TANK (Fig. C. 3)

The oil tank has a capacity of three pints and is fitted with an oil filter. It is important that only clean oil is used for topping up. Periodically the filter should be cleaned in paraffin, should the filter become damaged spares can be obtained from Wadkin Ltd.

THE OIL PUMP (Fig. C. 4)

The oil pump is situated under the infeed table and to the right hand side of the track and is driven from the track idler shaft. A priming handle is mounted on the front of the pump.

When the machine has been standing unused i. e. overnight it is essential to lubricate the track by using the priming handle (1) before starting the machine.

ADJUSTING THE OIL PUMP (Fig. C. 5)

The pump contains 6 plungers each feeding a point on the track which can be adjusted independently. The amount of oil to each point is set before the machine leaves the factory. To alter this amount the plunger screw 'A' should be turned anti clockwise to increase the flow of oil.

- | | | | |
|----|-------------------------|-----|--------------------|
| 1. | Stroke adjusting screw. | 7. | Cover |
| 2. | Delivery Cam Disc. | 8. | Distributor Shaft. |
| 3. | Delivery Plunger. | 9. | Outlet. |
| 4. | Suction Pipe. | 10. | Delivery Pipe. |
| 5. | Pump Body. | 11. | Worm Gear. |
| 6. | Pump Shaft. | 12. | Bearing Housing. |

ERRATA

The Oil Pump (Fig. C. 4.)

The priming handle must be depressed to operate the pump.

SECTION D

ELECTRICAL EQUIPMENT

FAILURE TO START

- 1 Electrical supply is not available at the machine.
- 2 Fuses have blown or have not been fitted.
- 3 Isolating switch has not been closed.
- 4 Lock off or stop button has not been released.

STOPPAGE DURING OPERATION AND FAILURE TO RESTART

- 1 Fuses have blown.
- 2 Overloads have tripped. They will re-set automatically after a short time and the machine can be restarted in the usual manner.

GENERAL

Check the earth connections periodically.
Never allow the machine to continue running when the pointer in the ammeter registers on the red section of the dial.
Always check direction of running when the machine is installed.

- | | |
|----------------------|-----------------|
| 1. Saw Motor | 7. "Off " |
| 2. Feed Motor | 8. Start Saw |
| 3. Feed Speed Switch | 9. Stop Saw |
| 4. Isolating Switch | 10. Master Stop |
| 5. Ammeter | 11. Start Feed |
| 6. "On" | 12. Stop Feed |

- | | | | |
|---|-------|---|------|
| D | Delta | L | Line |
| S | Star | F | Feed |

FEED SPEED SWITCH CONNECTIONS
CHILTON C16 B369

POSITION	CONTACTS CLOSED					
	L1-A3	L2-C3	L3-B3	NOT USED		
1	2-1	4-3	10-9	12-11	18-17	
	L1-A2	L2-B2	L3-C2	A3-C3	B3-C3	
2	6-5	8-7	14-13	15-16	19-20	

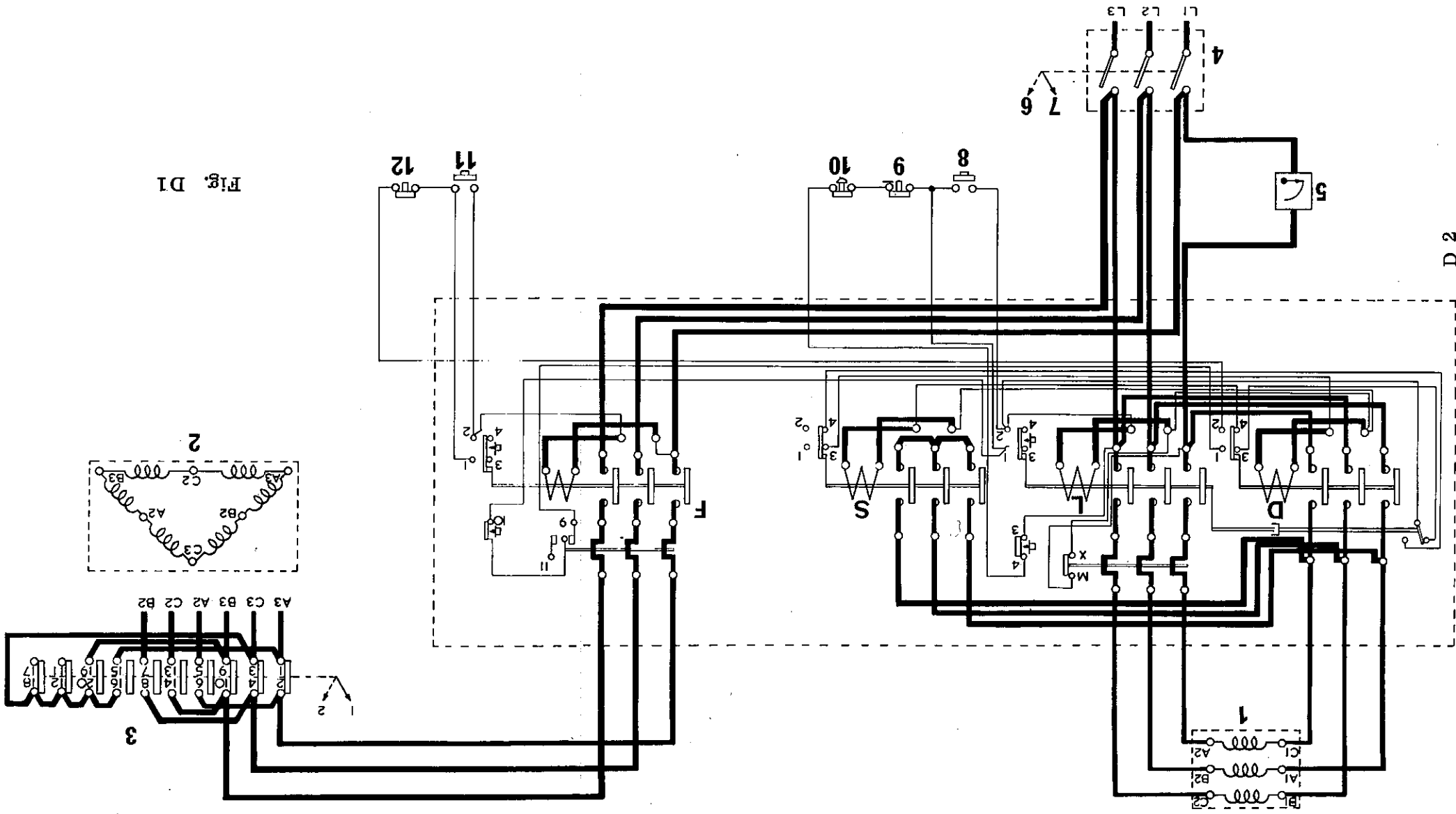

Fig. D1

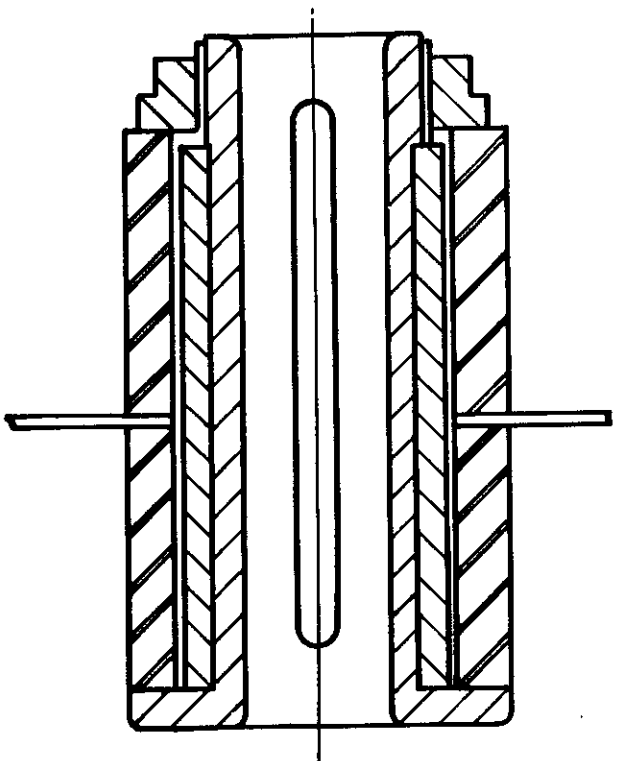

Fig. E 1

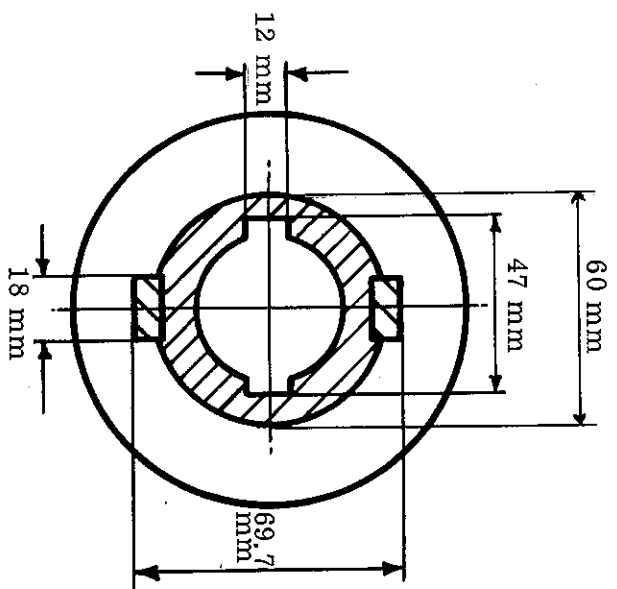

Fig. E 2

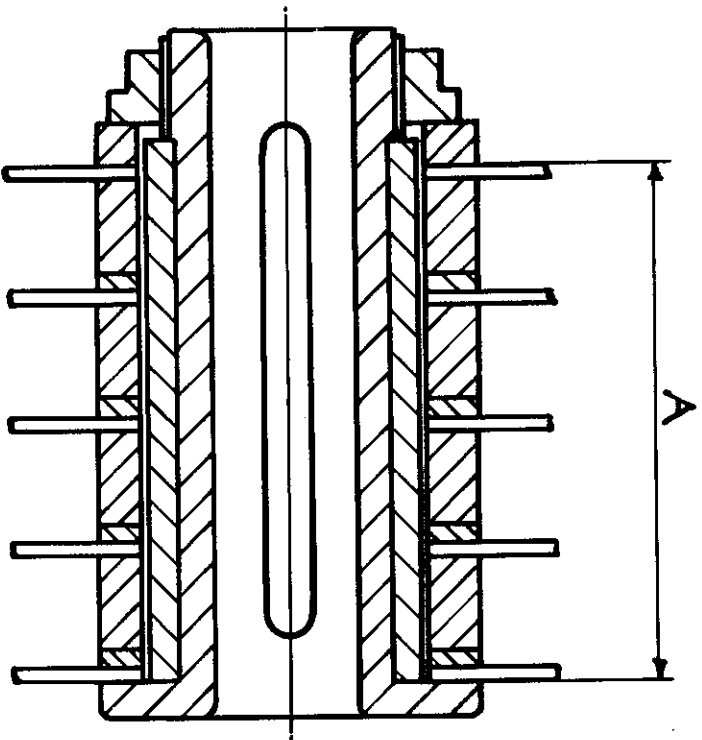

Fig. E 3

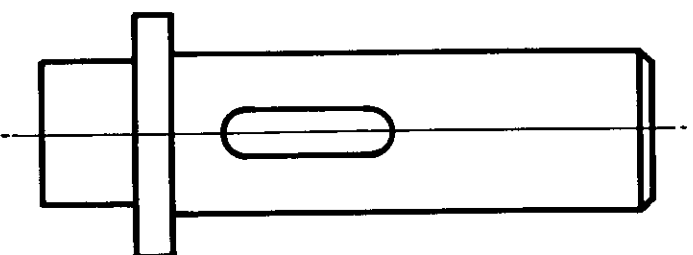

Fig. E 4

SECTION E

SAWS AND SLEEVES

Fig. E1. Single saw set up, using a 12" (300 mm) dia. saw. Saw collars are of different lengths for correctly positioning the saw between the pressure rollers. The collars are etched 'front' and 'rear'.

Fig. E2. Sectional view of sleeve giving diameter and key dimensions.

Fig. E3. This multiple set up using 10" (250 mm) maximum diameter saws has spacing collars designed to keep the number of sizes to a minimum and at the same time provide the largest possible variations. Two collars are used between each saw, one of which allows for the set of the saw.
 e. g. for $\frac{5}{16}$ " spacing use one $\frac{1}{8}$ " + .030" and one $\frac{3}{16}$ "
 for 9 mm. spacing use one 4 mm. + .775 mm. and one 5 mm.
 With the standard range of spacing collars, shown below, spacing can be altered by using several different sizes.
 e. g. for $\frac{7}{16}$ " spacing use one $\frac{3}{16}$ " + .030"; one 1" and one $\frac{1}{4}$ "
 for 37 mm. spacing use one 7 mm. + .775 mm., one 25 mm. and one 5 mm.
 The maximum distance 'A' is $5\frac{1}{2}$ " (140 mm).

Fig. E4. A dummy spindle enabling sleeves to be set up, off the machine, in a vice.

SAWS (ALLOY)

Diameter	Plate Thickness	No. of Teeth	Maximum Depth of Cut	Width on Cut	Set/Side	Part No.
12" (300 mm)	.109" (2.76 mm)	30	3" (75 mm)	.139" (3.53 mm)	.015" (.38 mm)	QS. 341
10" (250 mm)	.109" (2.76 mm)	26	$2\frac{1}{2}$ " (64 mm)	.139" (3.53 mm)	.015" (.38 mm)	QS. 342

SAWS (T. C. T.) with .015" (38 mm) overhanging both sides

Diameter	Plate Thickness	No. of teeth	Maximum Depth of Cut	Width on Cut	Part No.
12" (300 mm)	.109" (2.76 mm)	24	3" (75 mm)	.139" (3.53 mm)	QS. 340
10" (250 mm)	.109" (2.76 mm)	20	$2\frac{1}{2}$ " (64 mm)	.139" (3.53 mm)	QS. 343

The above saws for general purpose work have 60 mm. bore and two diametrically opposite keyways 18 mm. wide. Other saws can be supplied including metric standard 315 mm. diameter for single sawing.

SPACING COLLARS

Size	Part No.	Size	Part No.
.125" + .030"	PYT 70	3 mm + .775 mm	PYT 110
.187" + .030"	PYT 71	4 mm + .775 mm	PYT 111
.125"	PYT 100	5 mm + .775 mm	PYT 112
.187"	PYT 101	6 mm + .775 mm	PYT 113
.250"	PYT 102	7 mm + .775 mm	PYT 114
.375"	PYT 103	5 mm	PYT 115
.500"	PYT 104	10 mm	PYT 116
.625"	PYT 105	15 mm	PYT 117
.750"	PYT 106	20 mm	PYT 118
.875"	PYT 107	25 mm	PYT 119
1.000"	PYT 108		

SECTION F

SUGGESTED LIST OF WEARABLE PARTS TO BE KEPT AS SPARES

WHEN ORDERING SPARE PARTS ALWAYS QUOTE
MACHINE SYMBOL, NUMBER AND TEST NUMBER.

Quantity Per Machine	DESCRIPTION	Part Number
1	Complete trackway including dip guides	
1	Feed Chain comprising of- (60 Links (60 Pins (60 $\frac{3}{16}$ "dia. x 1" long Tension Pins heavy type.	PY 7 PY 66
1	'IVO' 6 Outlet Oil Pump, Type MU 6B, 12 DBV 864.	
1	Fenner Torque Arm, Type TD 325 (Special)	
1	Fenner Variable Speed Belt	Q 537
4	Saw Drive Belts (Fenner Alpha 710)	10 DU 10
2	Glacier Bushes (Mitre Gear Support Bracket)	12 DU 12
1	Glacier Bush (Gland Bracket for Handwheel shaft)	12 DU 12
25	Glacier Bushes (Swing for Pressure Rollers) (Filhoe for Pressure Stop Rod) (Pressure Rollers) (Swing Arm for Pressure Roller)	
3	Glacier Bushes (Bevel Box for- Pressure Rise and Fall)	12 DU 08
2	Glacier Bushes (Spindle Barrel)	18 DU 16
2	Glacier Bushes (Bevel Box for Pressure Rise and Fall)	10 DU 12
1	Compo Bush 1" Long.	SN 025
8	Pressure Springs	AC 358
1	Ammeter	
1	Saw Spindle	PY 251
2	Driving Keys	PY 288
1	Saw Spindle Locking Nut	PY 265
1	Feed Chain Driving Sprocket	PY 6
1	Bevel Pinion for Top Pressure Beam	PY 285
1	Bevel Gear for Top Pressure Beam	PY 286
1	Pressure Beam Raising Screw	PY 282
1	Pressure Beam Raising Nut	PY 210
29	Kickback Fingers	PY 236
34	Sprag Kickback Fingers	PY 237
1	Kickback Guard	PY 232
1	Kickback Guard	PY 233
1	Kickback Guard	PY 234
1	4" length of $\frac{3}{8}$ " bore Braided Hose	
1	15' 0" length of 5/32" O/dia. Nylon Pipe	
1	Tecalemit Oil Tank Filter, No. FP. 3319/102	
6	Enot Adaptors	Z 222
6	Enot Nuts	Z 29
6	Enot Nuts	Z 413
1	$\frac{1}{4}$ " Gland Nut No. L.U. 182)	
1	$\frac{1}{4}$ " Olive No. L.U. 160)	To be supplied
6	5/32" Nut No. WMB. 2164/1X)	with 'IVO' Pump
6	5/32" Olive No. SPRU. 1152X)	above.
<u>BEARINGS</u>		
2	Matched Saw Spindle Bearings (Front) Hoffman ACDB 145	
1	Saw Spindle Bearing (Rear) Hoffman R. 145	
2	Torrington NTA 1220)	
2	Torrington TRA 1220)	Saw Spindle Adjusting Screw
2	Torrington TRD 1220)	Pressure Beam Adjusting Screw
1	Feed Motor Adjusting Screw Bearing SKF. 05 Thrust	
2	Chain Idle Shaft Bearing FBC. DN. 208 Double Sealed	
2	Chain Drive Shaft Bearings Pollard, MFC. 1 $\frac{3}{4}$ "	
1	Set of Feed Motor Bearings (Check Machine No.)	
1	Set of Saw Spindle Motor Bearings (Check Machine No.)	

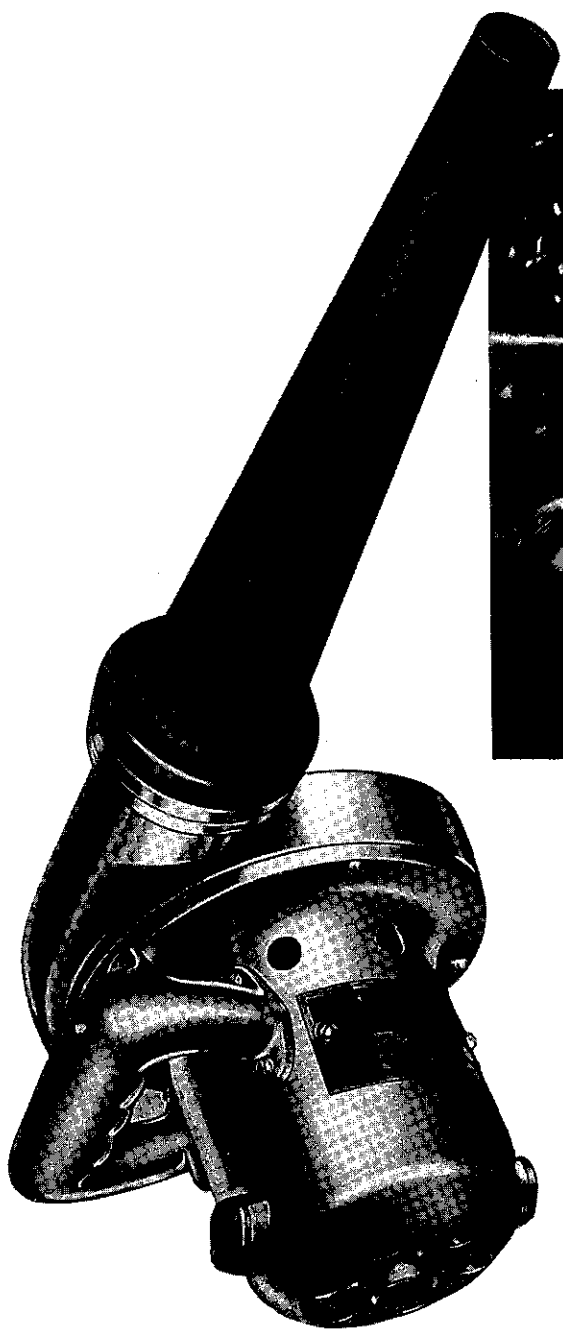

Fig. F 1

**BLOW AWAY HARMFUL DUST, CHIPS AND DIRT
WITH A WADKIN ELECTRIC BLOWER (Fig. F. 1)**

No motor can run at its maximum efficiency with its ventilating duct or control gear covered with dust and dirt. Sooner or later the resultant overheating will cause serious trouble.

Similarly, accumulation of chips and dust, in the mechanical parts of the machine can interfere with its efficiency. A few minutes a week for blowing down all Woodworking Machinery will be amply repaid in better and easier running, in increased life, and freedom from breakdown.

Blowers can be supplied for single phase A. C. or Direct Current for any voltage up to 250.

Please state voltage when ordering.