

T500

THICKNESSER

M/C No.	
TEST No.	

INSTRUCTION MANUAL

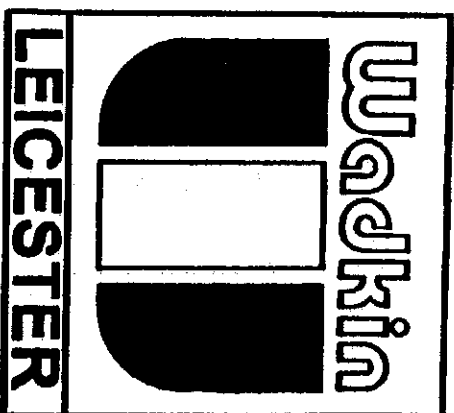

T500

THICKNESSER

INSTRUCTION MANUAL No. 3019

PREFACE

IMPORTANT

IT IS OUR POLICY AND THAT OF OUR SUPPLIERS TO CONSTANTLY REVIEW THE DESIGN AND CAPACITY OF OUR PRODUCTS. WITH THIS IN MIND WE WOULD REMIND OUR CUSTOMERS THAT WHILE THE DIMENSIONS AND PERFORMANCE DATA CONTAINED HEREIN ARE CURRENT AT THE TIME OF GOING TO PRESS, IT IS POSSIBLE THAT DUE TO THE INCORPORATION OF THE LATEST DEVELOPMENTS TO ENHANCE PERFORMANCE, DIMENSIONS AND SUPPLIERS MAY VARY FROM THOSE ILLUSTRATED

THIS MANUAL IS WRITTEN AS A GENERAL GUIDE. A TYPICAL MACHINE IS SHOWN TO ILLUSTRATE THE MAIN FEATURES.

**Failure to comply with instructions in this
book may invalidate the guarantee**

HEALTH & SAFETY SPECIFICATION	PAGES	2 & 3
SLINGING	PAGE	5
CLEANING	PAGE	6
FOUNDATION	PAGE	8
WIRING DETAILS	PAGES	8, 9, 10, 11, 12 & 13
LUBRICATION	PAGES	14 & 25
START/STOP CONTROLS	PAGE	14
VARIABLE FEED SPEED	PAGE	14
POWER RISE & FALL	PAGE	14
TABLE FINE ADJUSTMENT	PAGE	16
DIGITAL TIMBER THICKNESS INDICATOR	PAGE	16
MAINTENANCE	PAGE	17
TABLE ROLLERS	PAGE	17
FEED ROLLER & PRESSURE BAR SETTINGS	PAGE	17
CUTTERBLOCK BELT TENSION	PAGE	19
FEED CHAIN REMOVAL	PAGE	19
VARIABLE DRIVE BELT REMOVAL	PAGE	19
TABLE RISE & FALL CHAIN TENSION	PAGE	19
POWER RISE & FALL MAIN DRIVE TENSION & CLUTCH	PAGE	21
CUTTER SETTINGS	PAGE	23
MOTORISED KNIFE GRINDER	PAGE	24

FOR REPLACEMENT PARTS, TOOL AND ACCESSORIES CONTACT :

Wadkin Leicester
 Green Lane Works
 Leicester. LE5 4PF
 England
 Telephone: 0533 769111
 Telex: 34646 Wadkin G
 Fax: 0533 742310

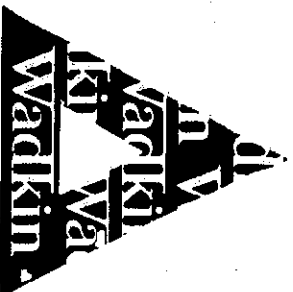

HEALTH & SAFETY

SAFETY OF WOODWORKING MACHINES

Woodworking machines can be dangerous if improperly used. The wide range of work of which they are capable, requires adequate safeguarding arrangements against possible hazards.

Many injuries to machinists are caused by carelessness or failure to use the guards provided or to adjust them correctly.

WADKIN LTD., supply machinery designed for maximum safety which they believe, as a result of thorough testing, minimizes the risks inevitable in their use. It is the user's responsibility to see that the following rules are complied with to ensure safety at work:

1. The operation of the machine should conform to the requirements of the Woodworking Machines Regulations 1974. All guards should be used and adjusted correctly.
2. Safe methods of working only should be adopted as given in the Health and Safety Work Booklet No.41, "Safety in the Use of Woodworking Machines", (obtainable from Her Majesty's Stationery Office) and as advised by Wadkin Ltd.
3. Only personnel trained in the safe use of a machine should operate it.
4. Before making adjustments or clearing chips, etc., the machine should be stopped and all movement should have ceased.
5. All tools and cutters must be securely fixed and the speed selected must be appropriate for the tooling.

SAFETY IS OUR WATCHWORD BUT THE USER MUST COMPLY WITH THE ABOVE RULES IN HIS OWN INTEREST. WE WOULD BE PLEASED TO ADVISE ON THE SAFE USE OF OUR PRODUCTS.

MACHINE SPECIFICATIONSPECIFICATION

T5

Capacity of Machine	508 x 250mm
Feed Speed	6-18m/min
HP of cutterblock motor	3.7kw
Speed of cutterblock	4,500rpm
Speed of motor	3,000rpm
Speed of motor	3,600rpm
Dia. of cutting circle	120mm
Dia. of feed rollers	85mm
Minimum stock length	280mm
Maximum stock removal	10mm
HP of rise and fall motor	0.25kw
Length of table	1000mm
Floor space	1000 x 1030mm
Approx. net weight	580kg
Approx. gross weight	650kg
Shipping dimensions	1.17x1.12x1.41m

BEARINGSBELTS

2 - off 62307-2RS	Cutterblock	2 - off SPZ 1600	Cutterblock
2 - off 6201 -2RS	Feed tension	1 - off 28/1180	Feed drive
2 - off 6006 -2RS	Feed drive	1 - off 480L075	Feed drive
2 - off 6204 -2RS	Feed drive		
2 - off 6004 -2RS	Feed drive Jockey pulley		
2 - off 6304 -2RS	Under table rollers		
4 - off MRK 355202	Rise & Fall Screws		
4 - off XWA 355201	Rise & Fall Screws		
4 - off IW 811807	Rise & Fall Screws		
1 - off UFL001	Feed handle		

SLINGING

ALWAYS USE A SLING WITHIN SAFE WORKING LOAD OF MACHINE WEIGHT.

Approx. net weight of machine 580 kg (T5)
Approx. gross weight of machine 723 kg (T5)

To lift machine, proceed as follows:-

1. Position one 610mm (24") long batten of wood at infeed end of machine table and a similar batten at outfeed end as shown in FIG.2.

NOTE: The battens should be positioned just under lip of the machine frame.

2. Raise table by handwheel "A", FIG. 2, until battens are nipped between table and frame.
3. Carefully position sling under both sides of table as shown in FIG.2, ensuring damage will not be caused to machine or sling during slinging operation.
4. Slowly lift machine and ensure slings are not slipping and machine is not tilting.

IMPORTANT: DO NOT WALK OR STAND UNDER MACHINE DURING SLINGING OPERATION.

**ALWAYS USE A SLING WITHIN SAFE WORKING
LOAD OF MACHINE WEIGHT**

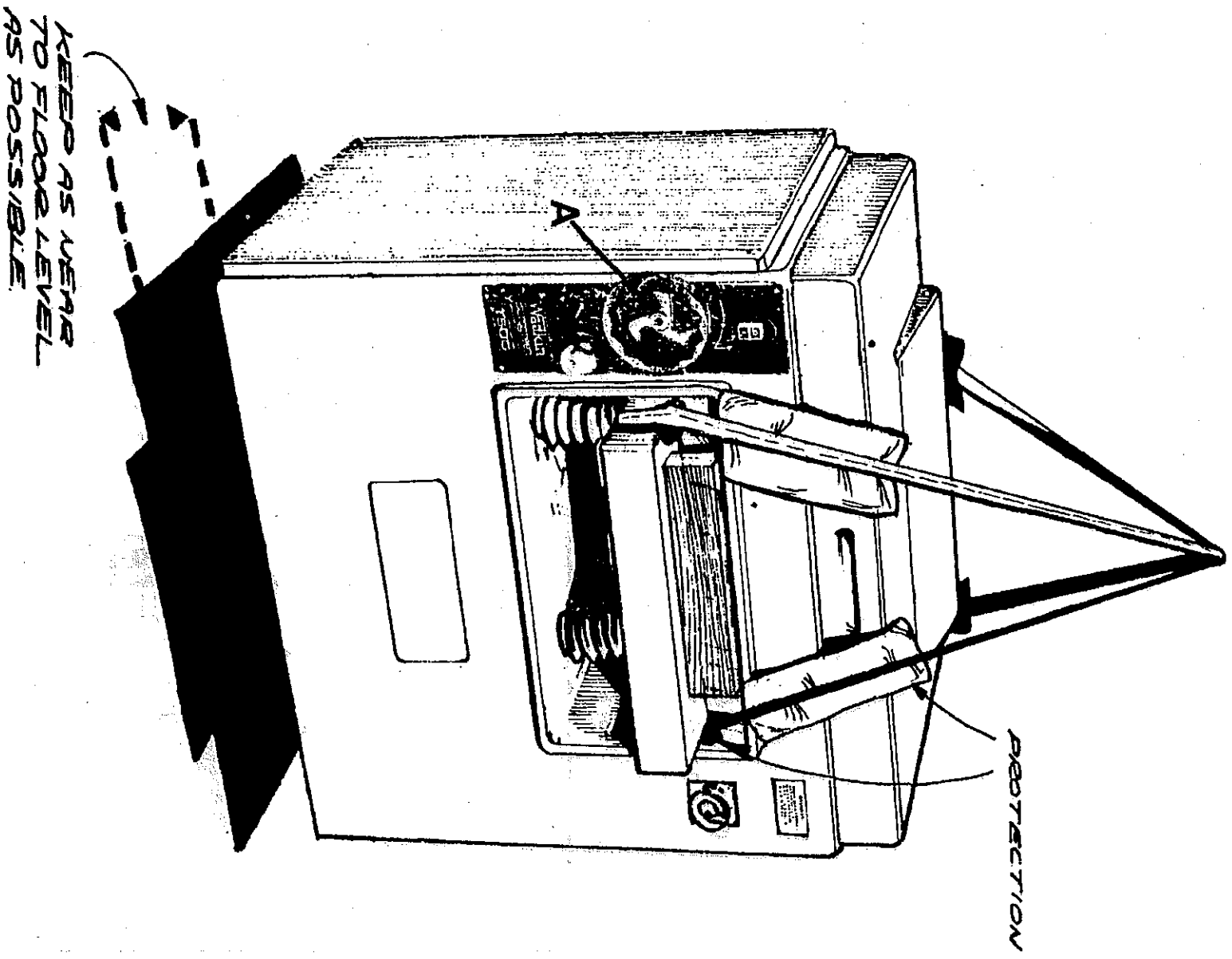

**IMPORTANT
ENSURE DAMAGE WILL NOT BE CAUSED
TO MACHINE DURING SLINGING OPERATION**

FIG. 2

CLEANING.

Clean protective coating from all bright parts by applying a cloth soaked in paraffin, turpentine or other solvent.

MARKING OUT.

1. Mark out floor and drill to suit 3 foundation bolts. These bolts can be supplied at an additional extra charge. (see FIG.3)

WIRING DETAILS.

The motor and control gear have been wired in before despatch. All that is required is to connect the power supply to the isolating switch. Points to note when connecting to power supply:

1. Check the voltage, phase, and frequency correspond to those on the motor plate, also the correct coils and heaters are fitted to the starter.
2. It is important that the correct cable is used to give the correct voltage to the starter as running on low voltage will damage the motor.
3. Check the main line fuses are of the correct capacity. See list inside starter cover.
4. Connect the line leads to the appropriate terminals.
5. Check all connections are sound.
6. Check the rotation of motor for the correct direction. If this is incorrect, reverse any two of the line lead connections. (See FIGS. 4 to 8 for wiring diagrams relevant to your machine).

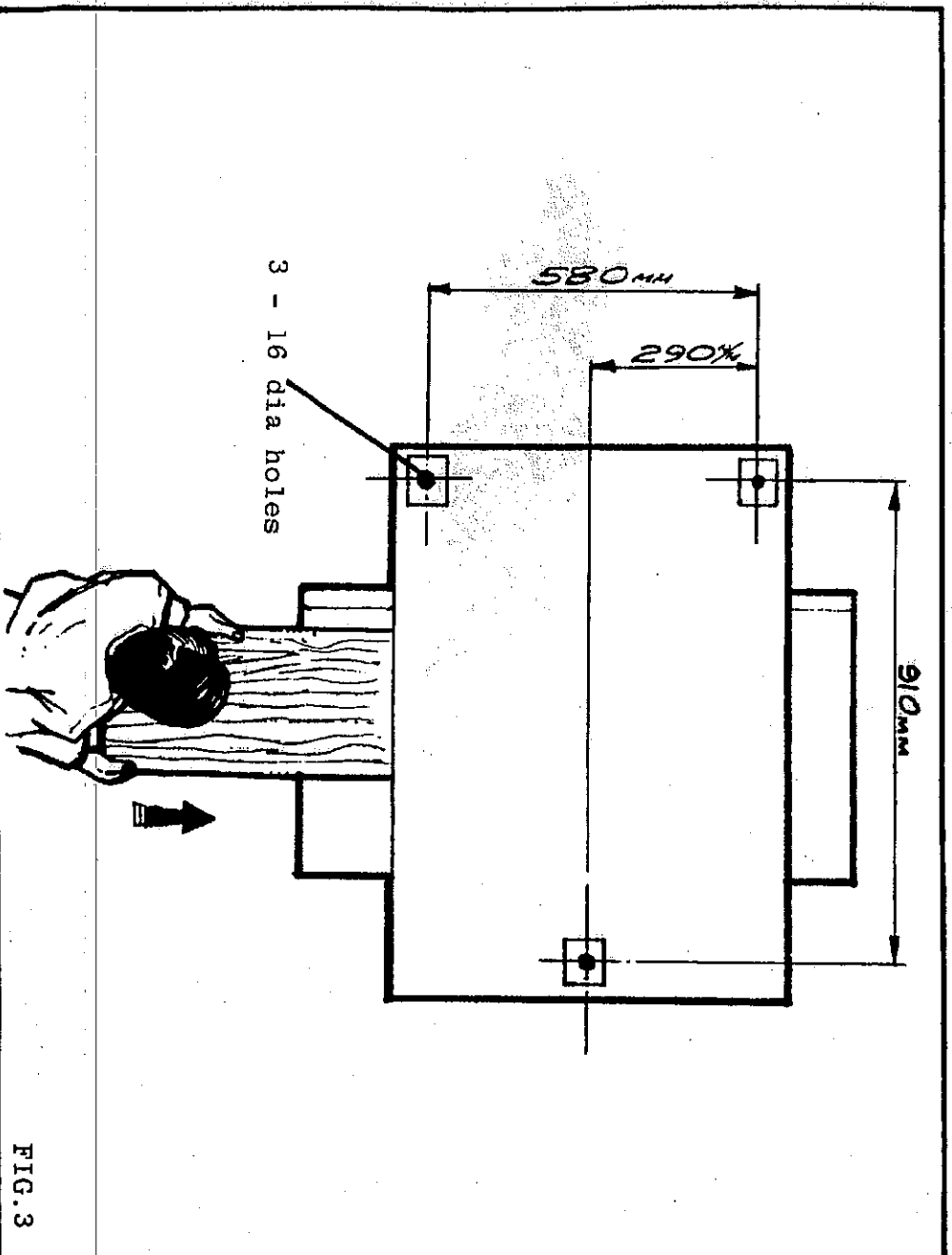

**WIRING DIAGRAM
FOR T5 STANDARD**

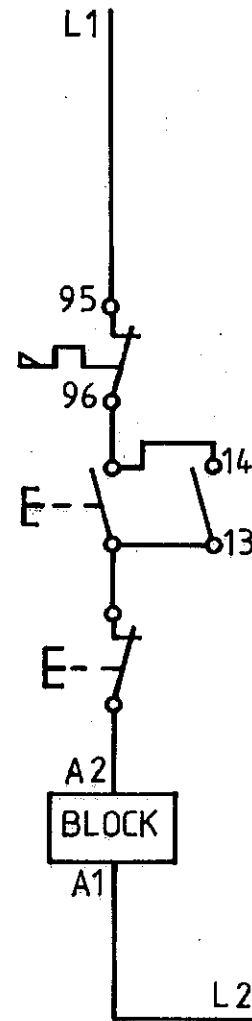
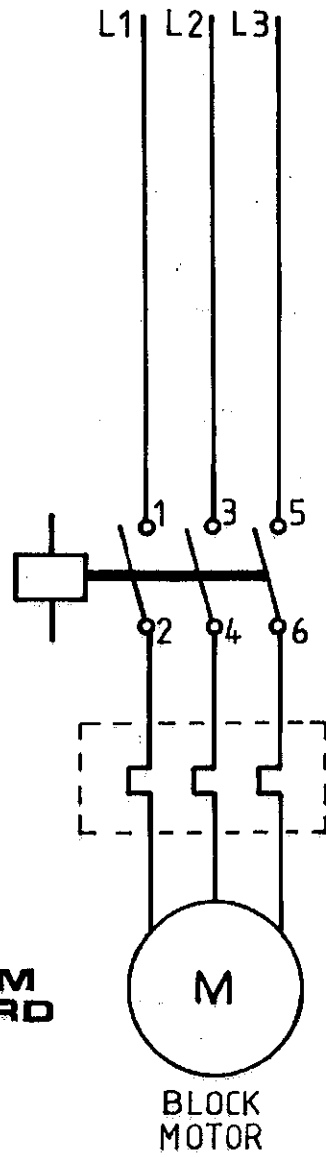

FIG. 4

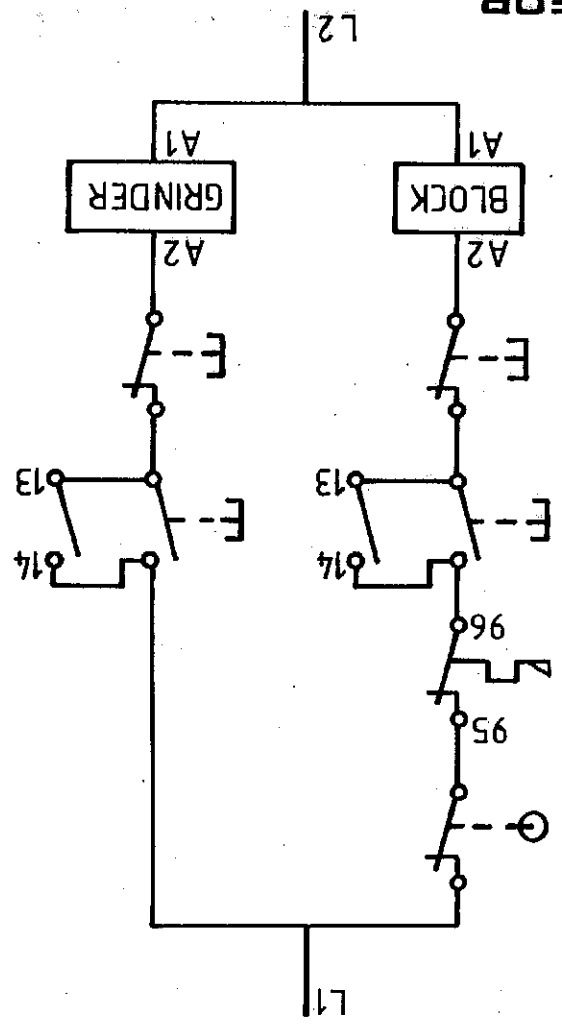
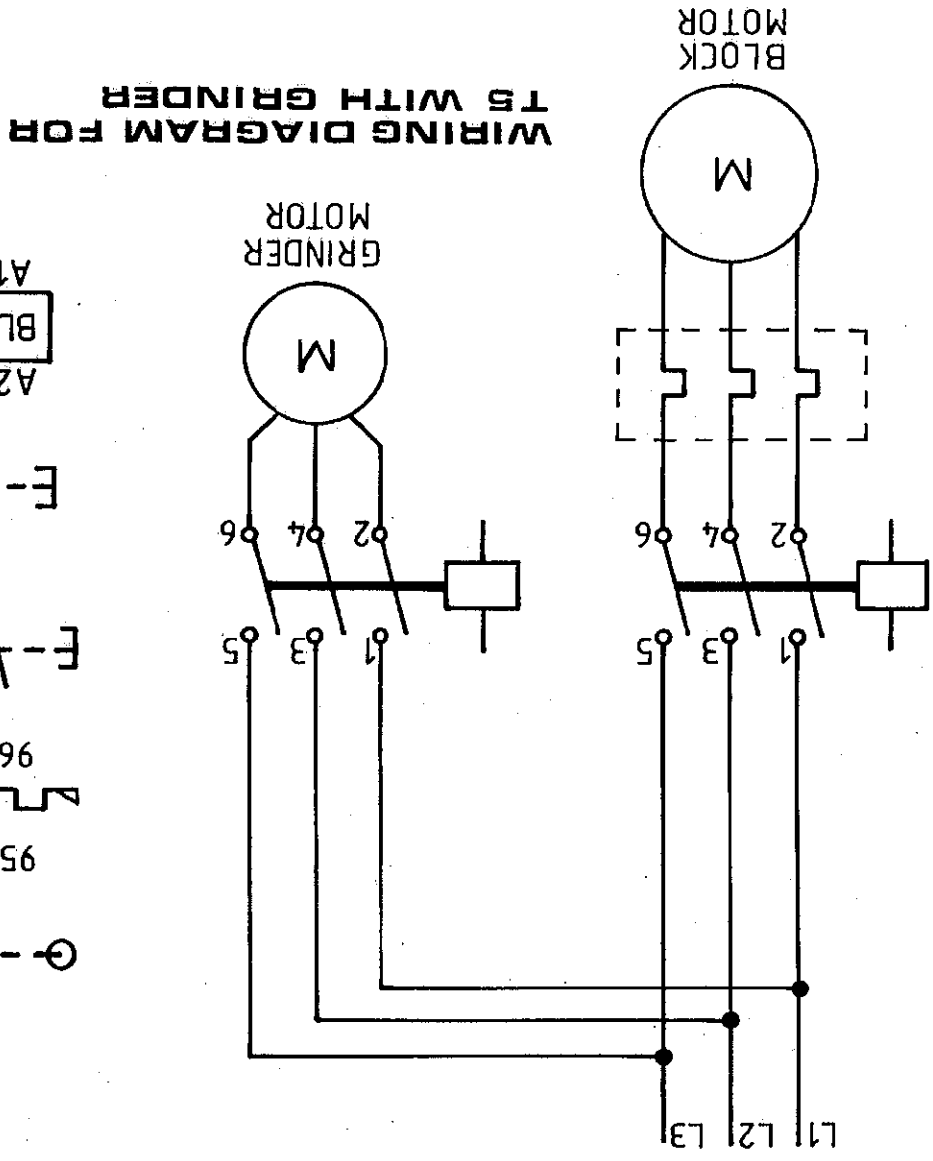
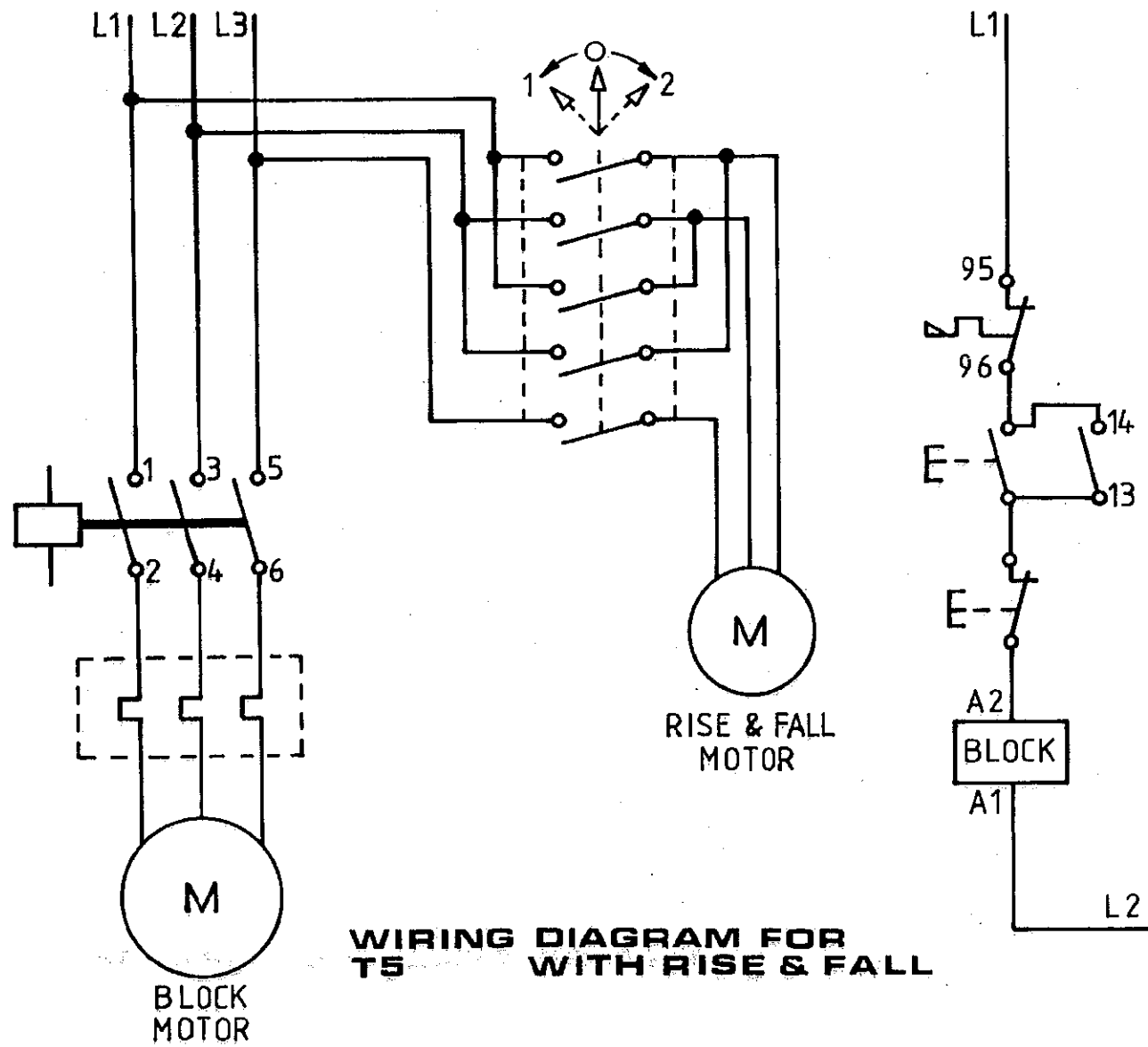

FIG. 5



WIRING DIAGRAM FOR T5 WITH RISE & FALL

FIG. 6

WIRING DIAGRAM FOR TRIP WITH RISES & FALL AND GRINDER

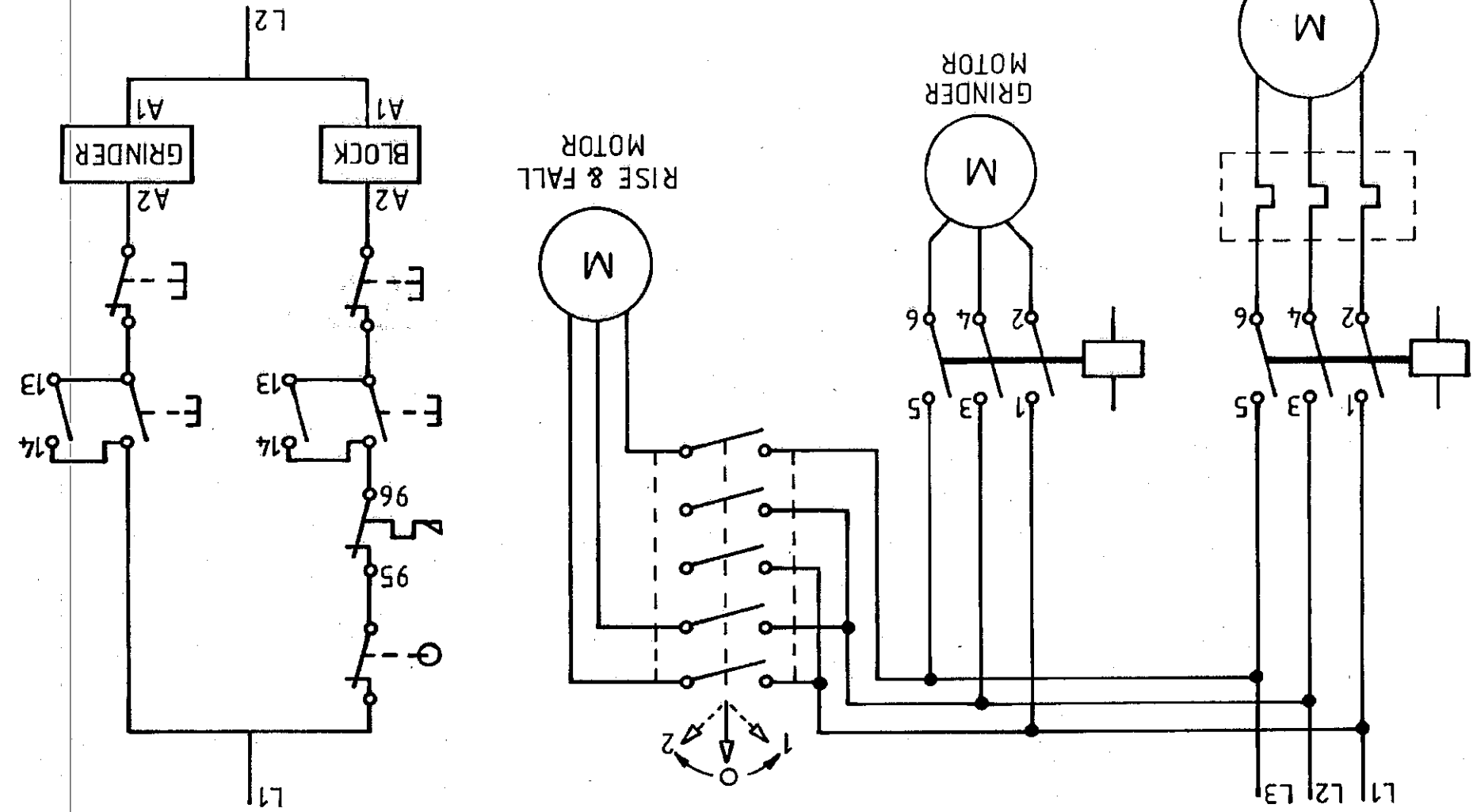
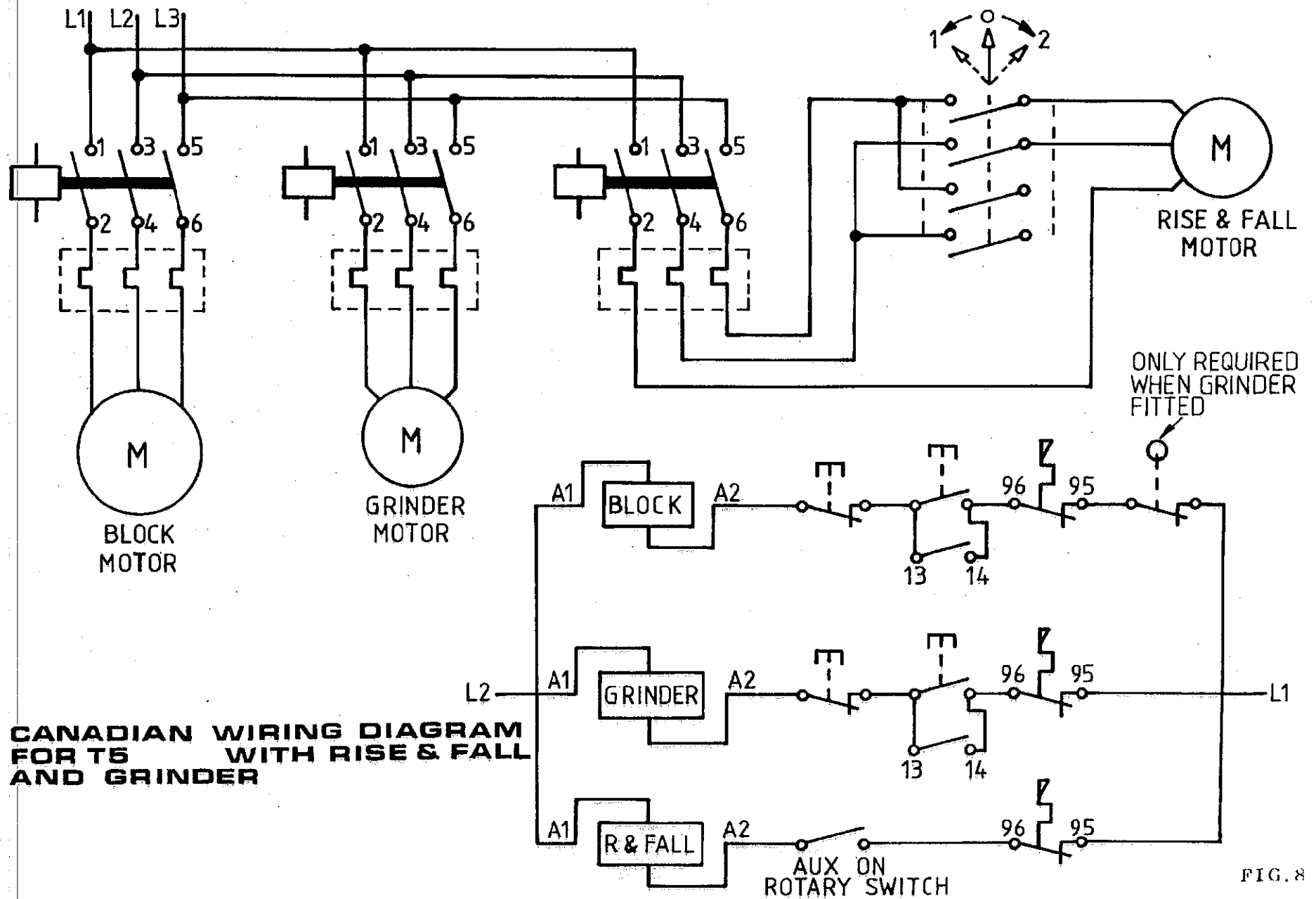

FIG. 7



CANADIAN WIRING DIAGRAM FOR T5 WITH RISE & FALL AND GRINDER

FIG. 8

LUBRICATION

The majority of machine working parts are designed to require no lubrication. All that is required is to periodically lightly oil the feed roller chain, situated inside the left base cover, and to loosen the shrouds and oil the four rise and fall screws.

START/STOP CONTROL

Before starting machine ensure cutter blades are locked in place and all guards are closed or in position.

When an isolator is fitted proceed as follows, (FIG.9) :-

To start turn isolator A to "1". Then on the left hand panel press the green button B to "1" to start cutter.

To stop press the red button "0" on control B.

To isolate machine, turn isolator A to "0" position.

Where no isolator is fitted control is simply via the panel start stop button.

VARIABLE FEED SPEED CONTROL

Feed roller drive is by infinitely variable pulley and belt from the machine motor. To alter feed speed proceed as follows :-

Turn variable feed speed handwheel C clockwise for slow speeds - anti clockwise to increase speed. (FIG.9)

1. WHEN ALTERING FEED SPEED MOTOR MUST BE RUNNING.

2. TO PREVENT UNDUE WEAR ON VARIABLE PULLEY, TURN HANDWHEEL THROUGH-OUT COMPLETE RANGE ONCE WEEKLY.

POWER RISE AND FALL (TS EXTRA)

Power table rise or fall drive is transmitted from motor through feed chain clutch to table rise and fall screw. This power driven rise and fall screws is in turn connected by chain to the 3 remaining rise and fall screws and manual rise and fall handwheel.

To power raise or lower table, proceed as follows :-

1. Ensure top cover and side covers are secured in position.
2. Move power rise and fall lever D in direction required to either raise or lower table.
3. Check digital timber thickness counter E.(FIG.9) to ensure correct table position for timber to be planed.

Note : For micro table adjustment turn handwheel F.

ON TS MODELS WITH HAND RISE AND FALL TURN HANDWHEEL G TO RAISE OR LOWER TABLE, DEPTH IS READ OFF ON SCALE AND POINTER ON PANEL FACIA.

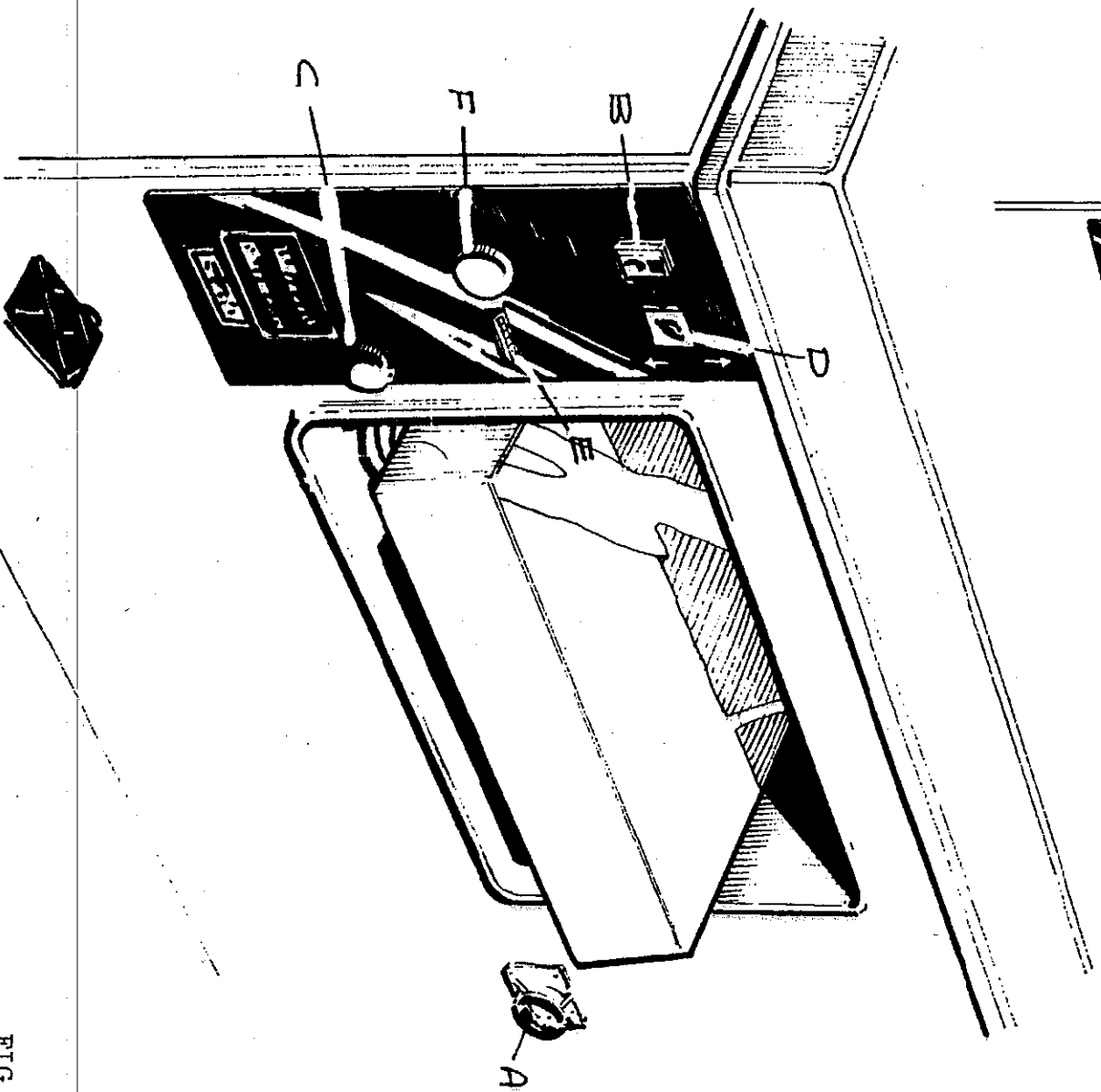
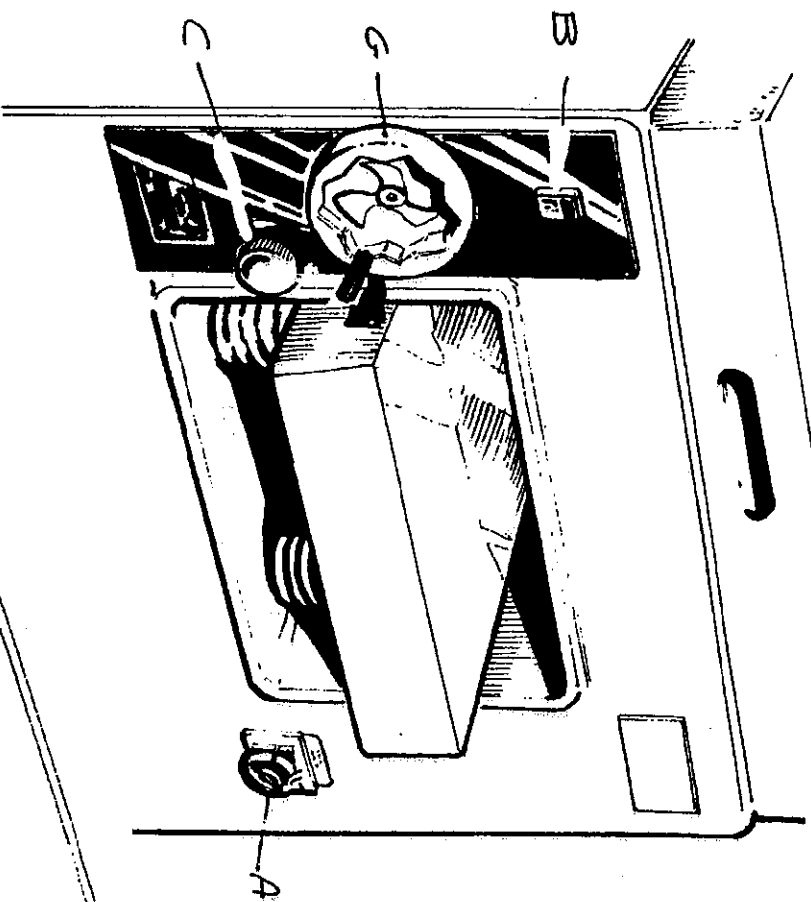

FIG. 9

TABLE FINE ADJUSTMENT (

T5 WITH POWER RISE AND FALL)

Apart from the power rise and fall previously mentioned, the machine is equipped with a hand fine adjustment F. Used in conjunction with the power rise and fall lever D (FIG.9) the thickness dimension required can be quickly and precisely set. Conversely handwheel F may be used to rise and fall the table through its full travel, is so desired.

DIGITAL TIMBER THICKNESS INDICATOR

A digital timber thickness indicator E is conveniently situated on the panel face. This scale is operated by vertical movement of the table. (FIG.9)

This indicator is pre-set before despatch from our works, but should the setting be disturbed for any reason proceed as follows to re-set indicator.

1. Isolate machine electrically.
2. Ensure table rise and fall chain is correctly tensioned.
3. Start machine and take sample timber thickness cut then accurately measure timber thickness.
4. Isolate machine electrically then remove left side drive cover.
5. Loosen the two M4 socket head grub screws J (FIG.11) and remove cable K, then turn shaft of indicator until indicator display corresponds to measured timber thickness.
6. When set correctly, refit cable K to indicator shaft and secure with the two M4 grub screws J. Refit left side drive cover.

MAINTENANCE

All adjustments and alignments following have been carefully set and checked and the complete machine thoroughly tested before despatch from the works.

During the first few weeks of operation and at regular intervals afterwards, certain items such as belt tension and chain tension should be checked carefully. When adjustments are necessary, proceed in accordance with the relative instructions given.

TABLE ROLLERS

The anti-friction rollers or bed rollers revolve on sealed for life bearings which require no lubrication. These rollers are pre-set in relation to the table surface.

It must be emphasised that a really good surface finish from a thickening machine is only possible when the face of the timber resting on the machine table is flat and has a reasonable finish. Wherever practicable this face should be pre-machined on a overhead jointer, or surfacer to remove twist and other irregularities.

FEED ROLLER AND PRESSURE BAR SETTINGS.

These are preset at the works and vertical adjustment relative to the cutterblock is neither possible nor necessary, provided the cutters are correctly set with the special setting gauge supplied with each machine. Should replacement feed rollers or pressure bars be fitted at any time, the settings should be very carefully checked with FIG.10.

Some slight advantage in finish or feeding may on occasions be obtained by increasing or decreasing the tension of the pressure bar or feed roller springs.

NOTE: The springs should never be compressed to a point where the feed rollers and pressure bars cannot lift sufficient to allow the maximum cut to be taken.

GENERAL HINTS.

1. When thickening long lengths of timber, always support after the machine table, otherwise a step will appear on either or both ends.
2. When a smooth finish is required, use the slow feed speed. For roughing when the finish is not important, use the fast feed speed.
3. For the best results always feed the timber to cut with the grain.
4. Should the timber stick when thickening the probable causes are as follows :

 - a. The spring pressure is too great on the rear pressure bar.
 - b. Not enough pressure on either front or rear feed rollers.

NOTE: See FEED ROLLER AND PRESSURE BAR SETTINGS.

- c. Machine table sticky due to timber resin. (Clean table)
- d. Wet timber being machined. (Use dry timber)

IMPORTANT: Always isolate machine electrically before adjustments, maintenance or cleaning.

FIG. 10

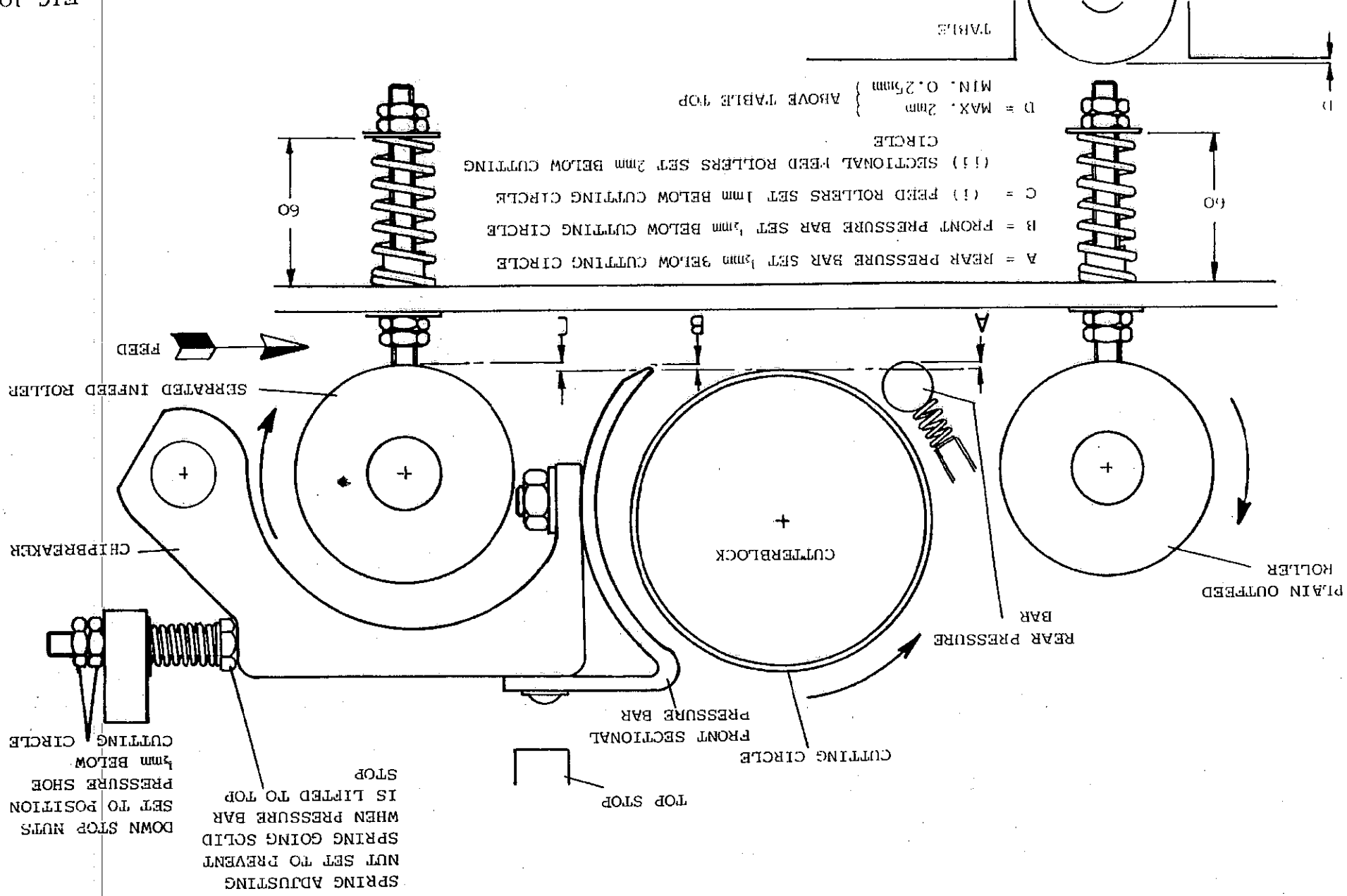

CUTTER SETTING

The knife is held in the cutterblock by a wedge, into which is fitted spring loaded balls, these balls hold the knife finger tight whilst the 5-M12 (T5) hexagon head screws are loose. This allows both hands to be free to adjust the blade and ensure that it will not slip back during setting or move whilst the wedge screws are being tightened up. Should any other method of cutter setting be employed the amount of cutter projection must correspond exactly with that given by the setting gauge supplied and failure to observe this instruction will result in bad feeding and poor finish.

To remove the knives and re-set with the "BURSGREEN" knife setting gauge, proceed as follows:-

- 1 Turn the cutterblock to approximately the position shown in FIG.14 and loosen the 5-M12 (T5) hexagon head screws, carefully remove knife from cutterblock.

NOTE: When grinding it is most important that knives are ground dead straight and balanced in pairs or sets.

- 2 To re-set the knives the cutterblock should be in the approximate position shown in FIG.14. Place the knife in between wedge and cutterblock with the blade drawn forward slightly.
- 3 Carefully secure the knife setting device 'A' FIG.13 or 14 (which when not in use is normally secured to the rear of the machine table), to the cutterblock with the two knurled locking screws 'B' as shown in FIG.13 or 14.
- 4 Whilst turning these locking screws 'B' FIG.13 or 14, knife will be lowered to correct setting which is reached when knurled screws are locked in position and knife just touches knife setting device.
- 5 When the knife is correctly set, tighten the 5-M12 (T5) hexagon head screws, remove knife setting device then securely lock the 5-M12 (T5) hexagon head screws.
- 6 Rotate cutterblock until the next knife is in position and repeat the procedure until all the knives have been set.
- 7 When changing knives it is advisable to check that all the locking screws are adequately lubricated and quite free. Periodically examine for damage or cracks. Any doubtful screws should be replaced and all screws well lubricated with "Moly slip" or similar oil, before replacing.

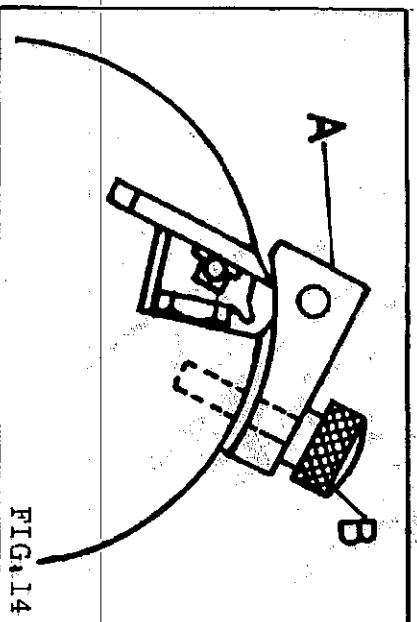

FIG.14

MOTORISED KNIFE GRINDER - FIG.15

To operate open top hood. By doing so the cutter block motor is isolated and the power is transferred to the grinder motor. Before commencing grinding operation locate the indexing plunger by lever A into one of the peg holes in the indexing device. Slide grinder to bring grinding wheel into position over knife blade and ensure grinding wheel is clear of knife blade before starting. Start grinder and screw down onto blade by knurled adjuster B until a light cut is made. Take firm hold of slide bracket C and push slide across traversing rapidly fully over length of blade and back to starting point, repeat until cut is finished and return grinder to starting point. Pull back lever A and index round to next peg hole on indexing device and relocate, repeat grinding operation and above sequence on all four knives.

NOTE:- Each cut adjustment should be made on all blades. DO NOT treat each blade individually as this will result in variable amounts of removal causing balance problems. Before starting each grinding stroke return grinder to position shown in diagram.

After treating all blades stop grinder motor and pull lever A back into free position.

NOTE.- If hand lever A is not in free position hood will not close. Replace hood before operating machine.

Modification to Knife Grinding Attachment

We have modified the knife grinding attachment to grind the knives at an angle of 45°, this will give a longer edge life, with no deterioration in surface finish. As we will continue to supply knives at 35°, the 45° angle will be the primary angle and the 35° will show as a secondary angle.

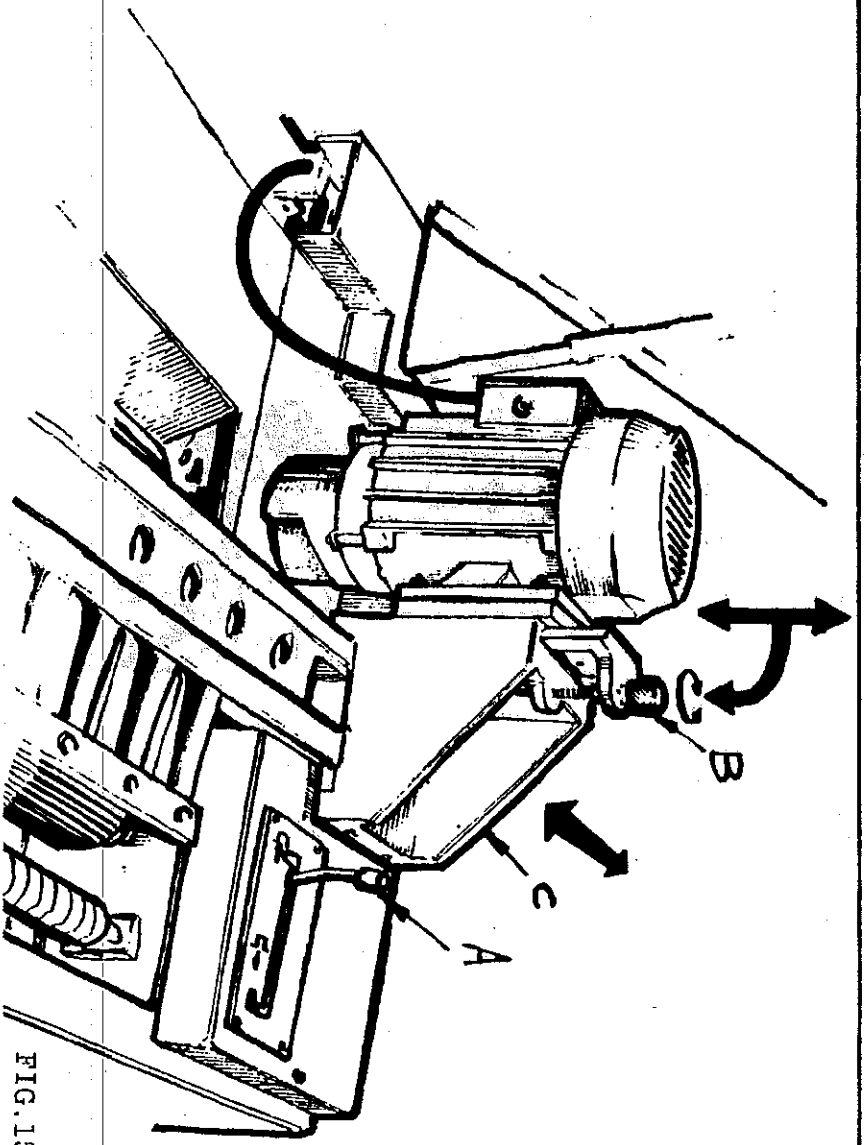

FIG.15

Application	APPROVED LUBRICANTS					
	Castrol	B.P.	Shell	Esso	Texaco/Caltex	Wadkin
Worm Boxes	ZN220	Energol CS320	Vitrea 320	Spartan EP220	Regal Oil 320	L2
General Lubrication	Magna 68	Energol HP68	Vitrea 68	Nuray	Ursa Oil P68	L4
Pneumatic Lubricators	Hyspin AWS32	Energol HL32	Tellus 37	Nuto H32	Rando Oil HD32	
Grease	Spheerol AP3	Energol L53	Alvania R3	Beacon 3	Regal Starfak Premium 3	L6
Brake Cables	Brake Cable grease	Energol L21M	Alvania R3	Esso Multi-purpose grease		